

NEBRASKA OECD TRACTOR TEST 1881 - SUMMARY 538

McCORMICK XTX 200 DIESEL

ALSO McCORMICK MTX 185 DIESEL

32 SPEED

POWER TAKE-OFF PERFORMANCE

Power HP (kW)	Crank shaft speed rpm	Gal/hr (l/h)	lb/hp.hr (kg/kW.h)	Hp.hr/gal (kW.h/l)	Mean Atmospheric Conditions
MAXIMUM POWER AND FUEL CONSUMPTION					
Rated Engine Speed—(PTO speed—1086 rpm)					
170.98 (127.50)	2200	10.20 (38.59)	0.417 (0.254)	16.77 (3.30)	
Standard Power Take-off Speed—(1000 rpm)					
182.83 (136.34)	2025	10.31 (39.05)	0.394 (0.240)	17.73 (3.49)	
Maximum Power (1 hour)					
192.30 (143.40)	1900	10.52 (39.83)	0.382 (0.233)	18.28 (3.60)	

VARYING POWER AND FUEL CONSUMPTION

170.98 (127.50)	2200	10.20 (38.59)	0.417 (0.254)	16.77 (3.30)	Air temperature
152.27 (113.55)	2300	9.74 (36.88)	0.447 (0.272)	15.63 (3.08)	80°F (27°C)
114.04 (85.04)	2300	7.80 (29.51)	0.478 (0.291)	14.63 (2.88)	Relative humidity
76.30 (56.90)	2300	5.88 (22.26)	0.539 (0.328)	12.98 (2.56)	26%
37.85 (28.23)	2300	3.76 (14.24)	0.695 (0.423)	10.06 (1.98)	Barometer
1.62 (1.21)	2300	2.06 (7.80)	8.877 (5.400)	0.79 (0.16)	28.74" Hg (97.33 kPa)

Maximum torque - 583 lb.-ft. (791 Nm) at 1351 rpm

Maximum torque rise - 42.7%

Torque rise at 1802 engine rpm - 34%

DRAWBAR PERFORMANCE

(Unballasted - Front Drive Engaged)

FUEL CONSUMPTION CHARACTERISTICS

Power Hp (kW)	Drawbar pull lbs (kN)	Speed mph (km/h)	Crank- shaft speed rpm	Slip %	Fuel Consumption lb/hp.hr (kg/kW.h)	Hp.hr/gal (kW.h/l)	Temp. °F (°C) cool- ing med	Air dry bulb	Barom. inch Hg (kPa)
Maximum Power—16th(3-2) Gear									
140.38 (104.68)	9580 (42.61)	5.49 (8.84)	2203	3.52	0.472 (0.287)	14.82 (2.92)	179 (82)	69 (21)	28.88 (97.80)
75% of Pull at Maximum Power—16th(3-2) Gear									
111.05 (82.81)	7191 (31.99)	5.79 (9.32)	2296	2.47	0.529 (0.322)	13.21 (2.60)	178 (81)	71 (22)	28.89 (97.83)
50% of Pull at Maximum Power—16th(3-2) Gear									
74.88 (55.84)	4796 (21.33)	5.85 (9.42)	2301	1.59	0.603 (0.367)	11.59 (2.28)	175 (79)	73 (23)	28.89 (97.83)
75% of Pull at Reduced Engine Speed—20th(3-4) Gear									
111.26 (82.96)	7185 (31.96)	5.81 (9.34)	1675	2.44	0.449 (0.273)	15.56 (3.06)	169 (76)	77 (25)	28.90 (97.87)
50% of Pull at Reduced Engine Speed—20th(3-4) Gear									
75.00 (55.93)	4793 (21.32)	5.87 (9.44)	1677	1.55	0.500 (0.304)	13.97 (2.75)	164 (73)	75 (24)	28.90 (97.87)

Location of tests: Nebraska Tractor Test Laboratory, University of Nebraska, Lincoln Nebraska, USA 68583-0832

Dates of tests: May 17-June 7, 2006

Manufacturer: McCormick Tractors Intr. Ltd., Doncaster, South Yorkshire, DN2 4PG, England

FUEL and OIL: Fuel No. 2 Diesel **Specific gravity converted to 60°/60°F (15°/15°C)** 0.8395 **Fuel weight** 6.990 lbs/gal (0.838 kg/l) **Oil SAE 15W40 API service classification** CG-4 **Transmission and hydraulic lubricant** McCormick HTX fluid **Front axle lubricant** API GL5 SAE 85W140 **Total time engine was operated** 30.0 hours

ENGINE: Make Iveco Diesel **Type** six cylinder vertical with turbocharger and air to air intercooler **Serial No.** *J100*001913* **Crankshaft** lengthwise **Rated engine speed** 2200 **Bore and stroke** 4.094" x 5.197" (104.0 mm x 132.0 mm) **Compression ratio** 17.5 to 1 **Displacement** 410 cu in (6728 ml) **Starting system** 12 volt **Lubrication** pressure **Air cleaner** two paper elements and aspirator **Oil filter** two full flow cartridges **Oil cooler** engine coolant heat exchanger for crankcase oil, radiator for hydraulic and transmission oil **Fuel filter** one paper element **Muffler** vertical **Cooling medium temperature control** thermostat and variable speed fan

ENGINE OPERATING PARAMETERS: Fuel rate: 69.2 - 73.4 lb/h (31.4 - 33.3 kg/h) **High idle:** 2275 - 2325 rpm **Turbo boost:** nominal 20.1 - 22.2 psi (139 - 153 kPa) as measured 21.3 psi (147 kPa)

CHASSIS: Type front wheel assist **Serial No.** *XT85AC4JJE3500599* **Tread width** rear 64.2" (1630 mm) to 125.0" (3175 mm) front 60.2" (1530 mm) to 87.8" (2230 mm) **Wheelbase** 113.1" (2873 mm) **Hydraulic control system** direct engine drive **Transmission** selective gear fixed ratio with partial (8) range operator controlled powershift **Nominal travel speeds mph (km/h)** first 1.12 (1.80) second 1.32 (2.12) third 1.54 (2.48) fourth 1.81 (2.91) fifth 2.14 (3.44) sixth 2.40 (3.87) seventh 2.51 (4.04) eighth 2.82 (4.54) ninth 2.95 (4.74) tenth 3.31 (5.32) eleventh 3.45 (5.55) twelfth 3.87 (6.23) thirteenth 4.59 (7.38) fourteenth 4.81 (7.74) fifteenth 5.38 (8.66) sixteenth 5.64 (9.08) seventeenth 6.31 (10.16) eighteenth 6.61 (10.64) nineteenth 7.39 (11.90) twentieth 7.75 (12.47) twenty-first 9.18 (14.77) twenty-second 10.07 (16.20) twenty-third 10.77 (17.33) twenty-fourth 11.81 (19.01) twenty-fifth 12.63 (20.32) twenty-sixth 13.85 (22.29) twenty-seventh 14.80 (23.81)

DRAWBAR PERFORMANCE
(Unballasted - Front Drive Engaged)
MAXIMUM POWER IN SELECTED GEARS

Power Hp (kW)	Drawbar pull lbs (kN)	Speed mph (km/h)	Crankshaft speed rpm	Slip %	Fuel Consumption lb/hp.hr (kg/kW.h)	Consumption Hp.hr/gal (kW.h/l)	Temp. °F(°C) cooling med	Air dry bulb	Barom. inch Hg (kPa)
10th(2-3) Gear									
125.25 (93.40)	15619 (69.48)	3.01 (4.84)	2264	12.54	0.532 (0.324)	13.13 (2.59)	169 (76)	64 (18)	28.88 (97.80)
11th(1-8) Gear									
126.93 (94.65)	15043 (66.92)	3.16 (5.09)	2213	10.13	0.525 (0.319)	13.32 (2.62)	173 (78)	69 (21)	28.71 (97.22)
12th(2-4) Gear									
135.93 (101.36)	14103 (62.73)	3.61 (5.82)	2190	7.10	0.496 (0.302)	14.10 (2.78)	174 (79)	65 (18)	28.88 (97.80)
13th(2-5) Gear									
143.41 (106.94)	13497 (60.04)	3.98 (6.41)	2035	6.95	0.474 (0.288)	14.76 (2.91)	181 (83)	74 (23)	28.72 (97.26)
14th(3-1) Gear									
142.96 (106.60)	12994 (57.80)	4.13 (6.64)	2012	6.89	0.476 (0.289)	14.70 (2.90)	183 (84)	83 (28)	28.77 (97.43)
15th(2-6) Gear									
147.66 (110.11)	12238 (54.44)	4.52 (7.28)	1941	5.56	0.462 (0.281)	15.13 (2.98)	180 (82)	75 (24)	28.73 (97.29)
16th(3-2) Gear									
149.96 (111.83)	12192 (54.23)	4.61 (7.42)	1889	5.52	0.450 (0.274)	15.52 (3.06)	182 (84)	77 (25)	28.74 (97.33)
17th(2-7) Gear									
149.34 (111.36)	10704 (47.61)	5.23 (8.42)	1890	4.36	0.454 (0.276)	15.41 (3.03)	182 (83)	76 (24)	28.73 (97.29)
18th(3-3) Gear									
151.21 (112.76)	10306 (45.84)	5.50 (8.85)	1894	4.17	0.449 (0.273)	15.56 (3.07)	184 (84)	79 (26)	28.75 (97.36)
19th(2-8) Gear									
150.40 (112.15)	9137 (40.64)	6.17 (9.93)	1886	3.69	0.451 (0.274)	15.50 (3.05)	182 (83)	81 (27)	28.76 (97.39)
20th(3-4) Gear									
152.19 (113.49)	8792 (39.11)	6.49 (10.45)	1889	3.60	0.447 (0.272)	15.64 (3.08)	187 (86)	80 (27)	28.76 (97.39)
21st(3-5) Gear									
150.48 (112.21)	7287 (32.42)	7.74 (12.46)	1887	2.51	0.450 (0.274)	15.52 (3.06)	183 (84)	82 (28)	28.77 (97.43)
22nd(4-1) Gear									
149.19 (111.25)	6583 (29.28)	8.50 (13.68)	1885	2.19	0.456 (0.277)	15.33 (3.02)	180 (82)	83 (28)	28.77 (97.43)

TRACTOR SOUND LEVEL WITH CAB	Front Wheel Drive	
	Disengaged dB(A)	Engaged dB(A)
At no load in 13th (2-5) gear	71.8	71.9
Bystander	---	---

TIRES AND WEIGHT

Rear tires - No., size, ply & psi(kPa)
Front tires - No., size, ply & psi(kPa)
Height of Drawbar
Static Weight with operator- Rear
- Front
- Total

Tested without ballast

Two 18.4R46; ***,17 (115)
Two 16.9R30; ***,17 (115)
19.0 in (485 mm)
10460 lb (4745 kg)
5725 lb (2597 kg)
16185 lb (7342 kg)

twenty-eighth 16.23 (26.12) twenty-ninth 19.22 (30.93) thirtieth 22.55 (36.29) thirty-first 25.84 (41.58) thirty-second 25.91 (41.70)(1900 RPM) reverse 1.35 (2.17), 1.58 (2.55), 1.86 (2.99), 2.17 (3.50), 2.58 (4.15), 2.90 (4.66), 3.03 (4.87), 3.39 (5.46), 3.55 (5.71), 3.98 (6.41), 4.16 (6.69), 4.67 (7.51) 5.52 (8.89), 5.79 (9.32), 6.48 (10.43), 6.79 (10.93), 7.60 (12.23), 7.97 (12.82), 8.90 (14.33), 9.33 (15.02), 11.05 (17.78), 12.96 (20.86), 15.21 (24.47), 17.82 (28.67) **Clutch** multiple wet disc electro-hydraulically operated by foot pedal **Brakes** multiple wet disc hydraulically operated by two foot pedals that can be locked together **Steering** hydrostatic **Power take-off** XTX 200 - 540 rpm at 1860 engine rpm or 1000 rpm at 2025 engine rpm, STX 185 - 540 rpm at 1877 engine rpm or 1000 rpm at 2209 engine rpm engine **Unladen tractor mass** 16010 lb (7262 kg)

NOTE 1: The engine of the McCormick XTX 200 is electronically controlled to provide two power levels. A "boosted" power level is available when the PTO is engaged, under load.

NOTE 2: The performance figures on this report are the result of replacing the electronic engine control module of the McCormick XTX185 with the XTX200 module.

REPAIRS AND ADJUSTMENTS: The PTO jackshaft failed during the PTO testing. The shaft was replaced and testing continued.

REMARKS: All test results were determined from observed data obtained in accordance with official OECD, SAE and Nebraska test procedures. This tractor did not meet the manufacturer's claims of 46% torque rise (boosted), 42% torque rise (unboosted), 34 GPM (129 lpm) hydraulic flow nor 3 point lift claim of 15287 lbs (6934 kg) at 24"(610 mm) behind the hitch points with the 89 mm lift cylinders. The manufacturer's claim of 43 GPM (163 lpm) remote flow with optional pump was not verified. For the maximum power tests, the fuel temperature at the injection pump was maintained at 170°F (77°C). The performance figures on this summary were taken from a test conducted under the OECD Code II test procedure.

We, the undersigned, certify that this is a true and correct report of official tractor Test No. **1881**, Nebraska Summary 538, August 23, 2006.

Leonard L. Bashford
Director

M.F. Kocher
V.I. Adamchuk
J.A. Smith
Board of Tractor Test Engineers

PTO performance in the "unboosted" mode

This vehicle is equipped with an electronically controlled engine Power management system that monitors and boosts engine power output in certain circumstances. This is achieved by electronically changing the characteristics of the engine power-speed curve. The engine Power management function ("boosted" power level) becomes activated when power transfer through the PTO exceeds a preset level. An override system was provided to enable PTO operations at the "unboosted" power level while the vehicle was stationary for test purposes. The results of of this PTO output test are presented below.

POWER TAKE-OFF PERFORMANCE

Power HP (kW)	Crank shaft speed rpm	Gal/hr (l/h)	lb/hp.hr (kg/kW.h)	Hp.hr/gal (kW.h/l)	Mean Atmospheric Conditions
MAXIMUM POWER AND FUEL CONSUMPTION					
Rated Engine Speed—(PTO speed—1086 rpm)					
160.80 (119.91)	2200	9.57 (36.22)	0.416 (0.253)	16.81 (3.31)	
Maximum Power (1 hour)					
178.83 (133.36)	1900	9.73 (36.83)	0.380 (0.231)	18.38 (3.62)	
VARYING POWER AND FUEL CONSUMPTION					
160.80 (119.91)	2200	9.57 (36.22)	0.416 (0.253)	16.81 (3.31)	Air temperature
142.75 (106.45)	2299	9.24 (34.98)	0.453 (0.275)	15.45 (3.04)	75°F (24°C)
107.01 (79.80)	2299	7.50 (28.38)	0.490 (0.298)	14.27 (2.81)	Relative humidity
71.38 (53.23)	2299	5.49 (20.80)	0.538 (0.327)	12.99 (2.56)	54%
35.15 (26.21)	2299	3.65 (13.81)	0.726 (0.441)	9.63 (1.90)	Barometer
1.62 (1.21)	2299	2.09 (7.91)	9.000 (5.475)	0.78 (0.15)	29.04" Hg (98.34 kPa)
Maximum torque - 543 lb.-ft. (736 Nm) at 1456 rpm Maximum torque rise - 41.4% Torque rise at 1800 engine rpm - 32%					

CATEGORY: III

Quick Attach: None	89 mm lift cylinders	100 mm lift cylinders
Maximum force exerted through whole range:	12385 lbs (55.1 kN)	16317 lbs (72.6 kN)
i) Opening pressure of relief valve:	NA	
	<u>one outlet set</u>	<u>two outlet sets combined</u>
Sustained pressure of the open relief valve:	2874 psi (198 bar)	2878 psi (198 bar)
ii) Pump delivery rate at minimum pressure and rated engine speed:	28.9 GPM (109.4 l/min)	32.4 GPM (122.6 l/min)
iii) Pump delivery rate at maximum hydraulic power:	27.3 GPM (103.3 l/min)	30.5 GPM (115.5 l/min)
Delivery pressure:	2243 psi (155 bar)	2487 psi (171 bar)
Power:	35.7 hp (26.6 kW)	44.3 hp (33.0 kW)

THREE POINT HITCH PERFORMANCE

Observed Maximum Pressure psi. (bar)	2880 (198)
Location:	lift cylinder
Hydraulic oil temperature: °F (°C)	145 (63)
Location:	hydraulic sump
Category:	III
Quick attach:	none

SAE Static Test (100 mm cylinders) - System pressure 2586 psi (178 Bar)

Hitch point distance to ground level in. (mm)	8.0 (203)	16.0 (406)	24.0 (610)	32.0 (813)	40.0 (1016)
Lift force on frame lb	21494	20242	20202	19804	19906
" " " " " (kN)	(95.6)	(90.0)	(89.9)	(88.1)	(88.5)

HITCH DIMENSIONS AS TESTED—NO LOAD
89 mm lift cylinders

	inch	mm
A	32.0	814
B	16.1	410
C	18.1	461
D	17.7	450
E	7.9	200
F	13.8	350
G	35.6	905
H	8.1	205
I	17.7	450
J	21.8	555
K	26.6	675
L	49.3	1253
M	25.7	653
N	39.5	1003
O	9.1	230
P	48.8	1240
Q	38.2	970
R	41.9	1063

HITCH DIMENSIONS AS TESTED—NO LOAD
100 mm lift cylinders

	OECD test inch	test mm	SAE test inch	test mm
A	30.8	781	30.8	781
B	16.1	410	16.1	410
C	18.1	461	18.1	461
D	17.7	450	17.7	450
E	12.2	310	12.2	310
F	13.8	350	13.8	350
G	36.2	920	36.2	920
H	8.1	205	8.1	205
I	17.7	450	17.7	450
J	22.4	570	22.4	570
K	26.6	675	26.6	675
L	49.3	1253	49.3	1253
M	25.7	653	25.7	653
N	39.5	1003	39.5	1003
O	9.0	228	8.0	203
P	49.4	1255	44.4	1128
Q	39.1	994	38.1	968
R	41.4	1053	42.2	1071

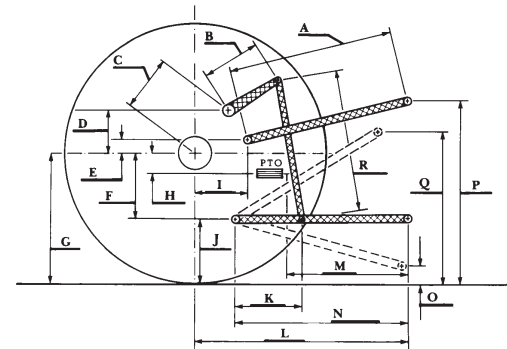

McCormick XTX 200 Diesel

Institute of Agriculture and Natural Resources
University of Nebraska–Lincoln