

NEBRASKA TRACTOR TEST 1883

AGCO LT75A DIESEL

16 SPEED

POWER TAKE-OFF PERFORMANCE

Power HP (kW)	Crank shaft speed rpm	Gal/hr (l/h)	lb/hp.hr (kg/kW.h)	Hp.hr/gal (kW.h/l)	Mean Atmospheric Conditions
MAXIMUM POWER AND FUEL CONSUMPTION					
Rated Engine Speed—(PTO speed—1100 rpm)					
78.41 (58.47)	2200	5.07 (19.17)	0.452 (0.275)	15.48 (3.05)	
Maximum Power (1 hour)					
87.08 (64.94)	2049	5.27 (19.95)	0.424 (0.258)	16.52 (3.26)	
Standard Power Take-off Speed - (1000 rpm)					
86.60 (64.58)	2000	5.17 (19.57)	0.418 (0.254)	16.75 (3.30)	

VARYING POWER AND FUEL CONSUMPTION

78.41 (58.47)	2200	5.07 (19.17)	0.452 (0.275)	15.48 (3.05)	Air temperature
67.34 (50.22)	2229	4.57 (17.30)	0.475 (0.289)	14.74 (2.90)	75°F (24°C)
50.61 (37.74)	2248	3.91 (14.81)	0.541 (0.329)	12.93 (2.55)	Relative humidity
34.58 (25.79)	2275	2.97 (11.24)	0.601 (0.601)	11.64 (2.29)	54%
17.87 (13.33)	2332	2.31 (8.76)	0.906 (0.551)	7.72 (1.52)	Barometer
1.41 (1.05)	2362	1.69 (6.38)	8.396 (5.107)	0.83 (0.16)	29.06" Hg (98.41 kPa)

Maximum torque - 289 lb.-ft. (391 Nm) at 1051 rpm
 Maximum torque rise - 54.0%
 Torque rise at 1800 rpm - 29%

TRACTOR SOUND LEVEL WITH CAB	Front wheel drive	
	Engaged dB(A)	Disengaged dB(A)
At no load in 8th(2D) gear	74.9	74.8
Bystander in 16th(4D) gear		81.0

TIRES AND WEIGHT

Rear Tires—No., size, ply & psi (kPa)
Front Tires—No., size, ply & psi (kPa)
Height of Drawbar
Static Weight with operator—Rear
 —Front
 —Total

Tested without ballast

Two 18.4R34; **; 16 (110)
 Two 14.9R24; **; 16 (110)
 19.0 in (485 mm)
 6060 lb (2749 kg)
 4055 lb (1839 kg)
 10115 lb (4588 kg)

Location of tests: Nebraska Tractor Test Laboratory, University of Nebraska, Lincoln Nebraska 68583-0832

Dates of tests: September 11 - 12, 2006

Manufacturer: AGCO Corporation, Duluth Georgia 30096

FUEL, OIL and TIME: Fuel No. 2 Diesel Specific gravity converted to 60°/60° F (15°/15°C) 0.8409 Fuel weight 7.002 lbs/gal (0.839 kg/l) Oil SAE 15W40 API service classification CE/CF-4 Transmission and hydraulic lubricant AGCO Power Fluid 821 XL fluid Front axle lubricant AGCO 715 gear lube Total time engine was operated 12.5 hours

ENGINE: Make Sisu Diesel Type four cylinder vertical with turbocharger Serial No. S05381 Crankshaft lengthwise Rated engine speed 2200 Bore and stroke 4.252" x 4.724" (108.0 mm x 120.0 mm) Compression ratio 18.5 to 1 Displacement 268 cu in (4397 ml) Starting system 12 volt Lubrication pressure Air cleaner one paper element and one polyester felt element Oil filter one full flow cartridge Oil cooler engine coolant heat exchanger for crankcase oil Fuel filter one paper element and water separator Muffler underhood Exhaust vertical Cooling medium temperature control one thermostat and variable speed fan

ENGINE OPERATING PARAMETERS: Fuel rate: 35.0 - 37.3 lb/h (15.9 - 16.9 kg/h) High idle: 2355 - 2415 rpm Turbo boost: nominal 12.1-14.7 psi (83 - 101 kPa) as measured 13.7 psi (94 kPa)

CHASSIS: Type front wheel assist Serial No. R103042 Tread width rear 64.0" (1626 mm) to 84.4" (2144 mm) front 56.6" (1438 mm) to 75.6" (1920 mm) Wheelbase 105.3" (2674 mm) Hydraulic control system direct engine drive Transmission selective gear fixed ratio with partial (4) range operator controlled powershift Nominal travel speeds mph (km/h) first 1.14 (1.83) second 1.40 (2.25) third 1.71 (2.75) fourth 2.10 (3.38) fifth 2.70 (4.35) sixth 3.32 (5.35) seventh 4.05 (6.52) eighth 4.98 (8.02) ninth 5.49 (8.83) tenth 6.75 (10.86) eleventh 8.23 (13.25) twelfth 10.13 (16.30), thirteenth 12.66 (20.37) fourteenth 15.57 (25.05), fifteenth 18.99 (30.56) sixteenth 23.17 (37.59) reverse 1.14 (1.83), 1.40 (2.25), 1.71 (2.75), 2.10, (3.38), 2.70 (4.35), 3.32 (5.35), 4.05 (6.52), 4.98 (8.02), 5.49 (8.83), 6.75 (10.86), 8.23 (13.25), 10.13 (16.30), 12.66 (20.37), 15.57 (25.05), 18.99 (30.56), 23.17 (37.59) Clutch multiple wet disc electro-hydraulically operated by foot pedal Brakes single wet disc hydraulically operated by two foot pedals which can be locked together Steering hydrostatic Power take-off 540 rpm at 1980 engine rpm or 1000 rpm at 2000 engine rpm Economy PTO 540 or 1000 rpm at 1550 engine rpm Unladen tractor mass 9940 lb (4509 kg)

THREE POINT HITCH PERFORMANCE (OECD Static Test)

CATEGORY: II

Quick Attach: None

Maximum force exerted through whole range:	7817 lbs (34.8 kN)	High lift option 9189 lbs (40.9 kN)
i) Opening pressure of relief valve:	NA	Combined flow with both pumps 3124 psi (215 bar)
Sustained pressure of the open relief valve:	2961 psi (204 bar)	3124 psi (215 bar)
ii) Pump delivery rate at minimum pressure and rated engine speed:	15.0 GPM (56.8 l/min)	25.1 GPM (95.0 l/min)
iii) Pump delivery rate at maximum hydraulic power:	13.9 GPM (52.6 l/min)	23.5 GPM (89.0 l/min)
Delivery pressure:	2629 psi (181 bar)	2548 psi (176 bar)
Power:	21.3 HP (15.9 kW)	34.9 HP (26.1 kW)

THREE POINT HITCH PERFORMANCE

Observed maximum pressure psi. (bar)	2770 (191)
Location:	lift cylinder
Hydraulic oil temperature: °F (°C)	152 (67)
Location:	hydraulic valve
Category:	II
Quick attach:	none

SAE Static Test—System pressure 2490 psi (172 Bar)

Hitch point distance to ground level in. (mm)	9.9 (251)	15.0 (381)	22.0 (559)	29.0 (737)	36.0 (914)
Lift force on frame lb	15561	12897	11475	10314	9126
" " " " " (kN)	(69.2)	(57.4)	(51.0)	(45.9)	(40.6)

High lift Option

SAE Static Test—System pressure 2490 psi (172 Bar)

Hitch point distance to ground level in. (mm)	10.2 (259)	15.0 (381)	22.0 (559)	29.0 (737)	36.0 (914)
Lift force on frame lb	18747	15849	14310	12789	11421
" " " " " (kN)	(83.4)	(70.5)	(63.7)	(56.9)	(50.8)

REPAIRS AND ADJUSTMENTS: No repairs or adjustments

REMARKS: All test results were determined from observed data obtained in accordance with official OECD, SAE and Nebraska test procedures. This tractor did not meet the manufacturer's claim of 26.4 GPM (100 lpm) combined hydraulic flow at remote outlets. For the maximum power tests, the fuel temperature at the injection pump inlet was maintained at 143°F (62°C).

We, the undersigned, certify that this is a true and correct report of official Tractor Test No. **1883**, November 28, 2006.

Roger M. Hoy
Director

M.F. Kocher
V.I. Adamchuk
J.A. Smith
Board of Tractor Test Engineers

	SAE test		OECD test	
	inch	mm	inch	mm
A	24.8	629	24.8	629
B	11.6	295	11.6	295
C	13.9	353	13.9	353
D	13.0	330	13.0	330
E	7.9	200	7.9	200
F	10.2	260	10.2	260
G	30.3	770	30.3	770
H	1.4	35	1.4	35
I	16.2	413	16.2	413
J	20.1	510	20.1	510
K	24.2	615	24.2	615
L	41.2	1046	41.2	1046
M	23.5	596	23.5	596
N	37.2	946	37.2	946
O	8.0	203	8.0	203
P	40.2	1020	44.1	1120
Q	33.5	850	33.5	850
R	29.0	737	29.0	737

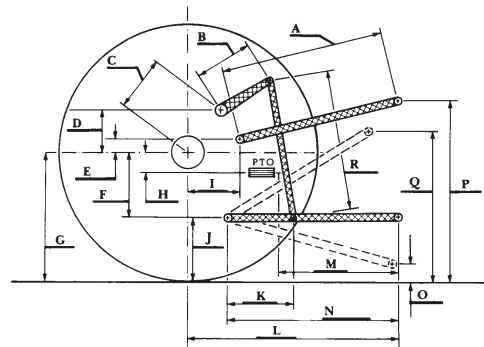

HITCH DIMENSIONS AS TESTED - NO LOAD

Shiftable PTO Performance

Economy mode

1000 PTO rpm @ 1550 engine rpm

Power HP (kW)	Crank shaft speed rpm	Gal/hr (l/h)	lb/hp.hr (kg/kW.h)	Hp.hr/gal (kW.h/l)
41.52 (30.96)	1545	2.70 (10.22)	0.455 (0.277)	15.38 (3.03)
30.88 (23.02)	1550	2.16 (8.16)	0.489 (0.297)	14.32 (2.82)
20.18 (15.05)	1549	1.60 (6.05)	0.555 (0.338)	12.62 (2.49)
10.22 (7.62)	1547	1.17 (4.43)	0.802 (0.488)	8.73 (1.72)
1.14 (0.85)	1546	0.77 (2.92)	4.736 (2.881)	1.48 (0.29)

Normal mode

1000 PTO rpm @ 2000 engine rpm

41.07 (30.63)	1989	3.13 (11.84)	0.533 (0.324)	13.13 (2.59)
31.03 (23.14)	2006	2.44 (9.24)	0.551 (0.335)	12.71 (2.50)
20.54 (15.31)	2003	2.01 (7.62)	0.687 (0.418)	10.20 (2.01)
10.24 (7.64)	1993	1.57 (5.95)	1.074 (0.653)	6.52 (1.28)
1.24 (0.92)	2003	1.20 (4.54)	6.781 (4.124)	1.03 (0.20)



AGCO LT75A Diesel