

NEBRASKA OECD TRACTOR TEST 2039—SUMMARY 830

JOHN DEERE 9410R DIESEL

18 SPEED

POWER TAKE-OFF PERFORMANCE

Power HP (kW)	Crank shaft speed rpm	Gal/hr (l/h)	lb/hp.hr (kg/kW.h)	Hp.hr/gal (kW.h/l)	Mean Atmospheric Conditions
MAXIMUM POWER AND FUEL CONSUMPTION SEE NOTE 1 - PAGE 2					
Rated Engine Speed—(PTO speed—1108 rpm)					
328.75 (245.15)	2099	21.04 (79.65)	0.451 (0.274)	15.62 (3.08)	Fuel used during active exhaust regeneration - 2.90 gal (11.00 l) (see Note 2 p.2)
Standard Power Take-off Speed—(PTO speed—1000 rpm)					
368.32 (274.65)	1895	21.47 (81.28)	0.411 (0.250)	17.15 (3.38)	
Maximum Power (1 hour)					
377.93 (281.82)	1681	21.20 (80.24)	0.395 (0.241)	17.83 (3.51)	

VARYING POWER AND FUEL CONSUMPTION

328.75 (245.15)	2099	21.04 (79.65)	0.451 (0.274)	15.62 (3.08)	Air temperature
279.70 (208.57)	2102	19.12 (72.38)	0.482 (0.293)	14.63 (2.88)	72°F (22°C)
212.00 (158.09)	2123	15.98 (60.48)	0.531 (0.323)	13.27 (2.61)	Relative humidity
142.70 (106.41)	2142	12.88 (48.76)	0.636 (0.387)	11.08 (2.18)	20%
71.60 (53.39)	2166	9.38 (35.30)	0.923 (0.562)	7.63 (1.50)	Barometer
1.60 (1.19)	2181	6.63 (25.08)	29.194 (17.758)	0.24 (0.05)	29.07" Hg (98.44 kPa)

Maximum Torque - 1233 lb.-ft. (1672 Nm) at 1452 rpm

Maximum Torque Rise - 50.0%

Torque rise at 1681 engine rpm - 44%

Power increase at 1681 engine rpm - 15.0%

DRAWBAR PERFORMANCE (Unballasted)

FUEL CONSUMPTION CHARACTERISTICS

Power Hp (kW)	Drawbar pull lbs (kN)	Speed mph (km/h)	Crank- shaft speed rpm	Slip %	Fuel Consumption lb/hp.hr (kg/kW.h)	Hp.hr/gal (kW.h/l)	Temp. °F (°C) cool- ing med	Air dry bulb	Barom. inch Hg (kPa)
Maximum Power—7th Gear									
321.85 (240.00)	25233 (112.24)	4.78 (7.69)	2101	3.1	0.477 (0.290)	14.76 (2.91)	189 (87)	66 (19)	28.74 (97.33)
75% of Pull at Maximum Power—7th Gear									
251.16 (187.29)	18928 (84.19)	4.98 (8.01)	2165	2.3	0.533 (0.324)	13.22 (2.60)	188 (86)	67 (19)	28.81 (97.56)
50% of Pull at Maximum Power—7th Gear									
170.37 (127.21)	12603 (56.06)	5.08 (8.18)	2188	1.5	0.626 (0.381)	11.26 (2.22)	186 (86)	68 (20)	28.80 (97.53)
75% of Pull at Reduced Engine Speed—10th Gear									
250.69 (186.94)	18941 (84.25)	4.96 (7.98)	1580	2.3	0.452 (0.275)	15.60 (3.07)	189 (87)	70 (21)	28.78 (97.46)
50% of Pull at Reduced Engine Speed—10th Gear									
171.02 (127.53)	12629 (56.17)	5.08 (8.18)	1602	1.5	0.493 (0.300)	14.31 (2.82)	187 (86)	70 (21)	28.79 (97.49)

Location of Tests: Nebraska Tractor Test Laboratory, University of Nebraska, Lincoln, Nebraska 68583-0832

Dates of Test: September 17 - October 8, 2012

Manufacturer: John Deere Tractor Works, 3500 East Donald St., P.O. Box 270, Waterloo Ia, 50704-0270

FUEL, OIL and TIME: Fuel No. 2 Diesel Specific gravity converted to 60°/60°F (15°/15°C) 0.8467 Fuel weight 7.050 lbs/gal (0.845 kg/l) Oil SAE 15W-40 API service classification CH-4 Transmission, hydraulic and final drive lubricant John Deere Hy-Gard fluid Total time engine was operated: 24.0 hours

ENGINE: Make John Deere Diesel **Type** six cylinder vertical with two turbochargers and air to air aftercooler **Serial No.** *RG6135R002710* **Crankshaft** lengthwise **Rated engine speed** 2100 **Bore and stroke** 5.197" x 6.496" (132.0 mm x 165.0 mm) **Compression ratio** 16.0 to 1 **Displacement** 826 cu in (13548 ml) **Starting system** 12 volt **Lubrication** pressure **Air cleaner** two paper elements and aspirator **Oil filter** one full flow cartridge **Oil cooler** engine coolant heat exchanger for crankcase oil, radiator for hydraulic oil, radiator for transmission, front and rear axle oil **Fuel filter** two paper cartridges **Fuel cooler** radiator for returned fuel **Exhaust** regenerative particulate filter integrated within a vertical muffler **Cooling medium temperature control** 2 thermostats and variable speed fan

ENGINE OPERATING PARAMETERS: Fuel rate: Stationary PTO operation 141.5 - 153.4 lb/h (64.2 - 69.6 kg/h) (385 engine hp) 136.4 - 147.8 lb/h (61.9 - 67.0 kg/h), (410 engine hp) 146.3 - 158.5 lb/h (66.4 - 71.9 kg/h) **High idle:** 2150 - 2250 rpm (2160 - 2200 rpm with PTO engaged) **Turbo boost:** (410 engine hp) nominal 29.0 - 33.6 psi (200 - 230 kPa) as measured 31.6 psi (218 kPa)

CHASSIS: Type four wheel drive with duals **Serial No.** *1RW9410RKCP002316* **Tread width** rear 59.1" (1500 mm) to 131.8" (3348 mm), front 59.1" (1500 mm) to 131.8" (3348 mm) **Wheelbase** 137.8" (3500 mm) **Hydraulic control system** direct engine drive **Transmission** selective gear fixed ratio with full range operator controlled power shift **Nominal travel speeds mph (km/h)** first 2.37 (3.81) second 2.91 (4.69) third 3.23 (5.19) fourth 3.60 (5.79) fifth 3.96 (6.38) sixth 4.42 (7.12) seventh 4.90 (7.89) eighth 5.47 (8.81) ninth 6.03 (9.71) tenth 6.74 (10.84) eleventh 7.46 (12.00) twelfth 8.25 (13.27) thirteenth 9.18 (14.77) fourteenth 10.15 (16.33) fifteenth 12.54 (20.18) sixteenth 15.43 (24.83) seventeenth 19.08 (30.70) eighteenth 23.48 (37.78) reverse 2.37 (3.81), 3.23 (5.19), 3.60 (5.79), 4.90 (7.89), 5.47 (8.81), 7.46 (12.00)

DRAWBAR PERFORMANCE

(Unballasted at 2100 rpm)

MAXIMUM POWER IN SELECTED GEARS

Power Hp (kW)	Drawbar pull lbs (kN)	Speed mph (km/h)	Crank- shaft speed rpm	Slip %	Fuel Consumption lb/hp.hr (kg/kW.h)	Temp. °F (°C) cool- ing med	Barom. inch Hg (kPa)		
2nd Gear									
249.63 (186.15)	36433 (162.06)	2.57 (4.14)	2128	13.7	0.577 (0.351)	12.21 (2.41)	188 (87)	68 (20)	28.58 (96.78)
3rd Gear									
286.28 (213.48)	35325 (157.13)	3.04 (4.89)	2101	6.4	0.511 (0.311)	13.81 (2.72)	188 (86)	63 (17)	28.59 (96.82)
4th Gear									
311.96 (232.62)	34213 (152.18)	3.42 (5.50)	2101	5.9	0.492 (0.300)	14.32 (2.82)	187 (86)	55 (13)	28.87 (97.77)
5th Gear									
316.71 (236.17)	31035 (138.05)	3.83 (6.16)	2100	4.2	0.485 (0.295)	14.53 (2.86)	187 (86)	50 (10)	28.86 (97.73)
6th Gear									
318.10 (237.21)	27728 (123.34)	4.30 (6.92)	2101	3.8	0.486 (0.295)	14.51 (2.86)	189 (87)	67 (19)	28.73 (97.29)
7th Gear									
321.85 (240.00)	25233 (112.24)	4.78 (7.69)	2101	3.1	0.477 (0.290)	14.76 (2.91)	189 (87)	66 (19)	28.74 (97.33)
8th Gear									
320.95 (239.33)	22509 (100.12)	5.35 (8.60)	2101	2.6	0.477 (0.290)	14.78 (2.91)	189 (87)	61 (16)	28.75 (97.36)
9th Gear									
320.08 (238.68)	20224 (89.96)	5.94 (9.55)	2101	2.3	0.481 (0.293)	14.66 (2.89)	188 (87)	64 (18)	28.75 (97.36)
10th Gear									
319.82 (238.49)	18124 (80.62)	6.62 (10.65)	2101	2.1	0.482 (0.293)	14.62 (2.88)	189 (87)	68 (20)	28.74 (97.33)
11th Gear									
319.91 (238.56)	16380 (72.86)	7.33 (11.79)	2100	1.9	0.481 (0.292)	14.66 (2.89)	188 (87)	68 (20)	28.73 (97.29)
12th Gear									
319.60 (238.33)	14696 (65.37)	8.16 (13.12)	2100	1.7	0.484 (0.295)	14.56 (2.87)	190 (88)	68 (20)	28.74 (97.33)

TRACTOR SOUND LEVEL WITH CAB

	dB(A)
At no load in 6th gear	72.8
Transport speed - no load - 18th gear	73.7
Bystander in 18th gear	87.2

TIRES, BALLAST AND WEIGHT

Rear Tires - No., size, ply & psi (kPa)

Front Tires - No., size, ply & psi (kPa)

Height of Drawbar

Static Weight with operator - Rear

- Front

- Total

Tested Without Ballast

Four 480/80R46;***;12(85)

Four 480/80R46;***;19(130)

21.5 in (545 mm)

15330 lb (6954 kg)

23630 lb (10718 kg)

38960 lb (17672 kg)

Clutch wet multiple disc hydraulically actuated by foot pedal **Brakes** wet multiple disc hydraulically actuated foot pedal **Steering** hydrostatic and articulated **Power take-off** 1000 rpm at 1895 engine rpm **Unladen tractor mass** 38785 lb (17593 kg)

REPAIRS AND ADJUSTMENTS: The clutch control module was replaced. Testing continued after repair.

NOTE 1. The engine on this model operates in a derated mode when the PTO is engaged. This run was done with the field cruise system engaged

NOTE 2. The manufacturer declares that the average time between active regenerations is 15 hours, while operated in Auto Filter Cleaning Mode, at rated speed, full PTO load, under steady state conditions.

NOTE 3. The 9410R engine has an electronic control system which provides a vehicle protection system to avoid overloading the drive train. This system provides two different engine power levels. At 2100 rpm the engine produces up to 385 hp when the transmission is in forward gears 1 through 3. The engine produces 410 hp at 2100 rpm for all other gears.

REMARKS: All test results were determined from observed data obtained in accordance with official OECD, SAE and Nebraska test procedures. For the maximum power tests the fuel temperature at the primary fuel filter was maintained at 100°F (38°C). This tractor did not meet the manufacturer's remote hydraulic flow claim of 37 gpm (140 lpm), from a single outlet, with the manual transmission. The performance figures on this summary were taken from a test conducted under the OECD Code 2 test procedure.

We, the undersigned, certify that this is a true and correct report of official Tractor Test No. **2039**, Nebraska Summary 830, February 22, 2013.

Roger M. Hoy
Director

M.R. Riley
P.J. Jasa
J.D. Luck
Board of Tractor Test Engineers

DRAWBAR PERFORMANCE
(Unballasted at 1800 RPM)
MAXIMUM POWER IN SELECTED GEARS

Power Hp (kW)	Drawbar pull lbs (kN)	Speed mph (km/h)	Crank- shaft speed rpm	Slip %	Fuel Consumption lb/hp.hr (kg/kW.h)	Temp. °F(°C) cool- ing med	Air dry bulb	Barom. inch Hg (kPa)	
2nd Gear									
253.43 (188.98)	36814 (163.76)	2.58 (4.15)	2122	13.0	0.569 (0.346)	12.38 (2.44)	189 (87)	67 (19)	28.59 (96.82)
3rd Gear									
287.29 (214.23)	36629 (162.93)	2.95 (4.74)	2077	8.4	0.512 (0.312)	13.76 (2.71)	188 (86)	64 (18)	28.60 (96.85)
4th Gear									
317.08 (236.44)	36106 (160.61)	3.29 (5.29)	2064	7.7	0.496 (0.302)	14.22 (2.80)	189 (87)	65 (18)	28.59 (96.82)
5th Gear									
340.06 (253.58)	35877 (159.59)	3.56 (5.72)	2013	7.2	0.477 (0.290)	14.78 (2.91)	188 (86)	54 (12)	28.87 (97.76)
6th Gear									
351.65 (262.22)	33764 (149.79)	3.92 (6.30)	1945	5.4	0.460 (0.280)	15.33 (3.02)	188 (87)	51 (10)	28.87 (97.76)
7th Gear									
360.03 (268.47)	31753 (141.24)	4.25 (6.84)	1905	5.1	0.449 (0.273)	15.70 (3.09)	193 (89)	66 (19)	28.74 (97.33)
8th Gear									
367.12 (273.76)	30648 (136.33)	4.50 (7.23)	1800	4.4	0.437 (0.266)	16.15 (3.18)	192 (89)	63 (17)	28.75 (97.36)
9th Gear									
367.68 (274.18)	27387 (121.82)	5.04 (8.10)	1800	3.6	0.434 (0.264)	16.25 (3.20)	193 (89)	65 (18)	28.74 (97.33)
10th Gear									
368.93 (275.11)	24640 (109.60)	5.62 (9.04)	1800	3.1	0.434 (0.264)	16.23 (3.20)	195 (90)	68 (20)	28.74 (97.33)
11th Gear									
369.15 (275.27)	22212 (98.80)	6.23 (10.03)	1800	2.7	0.431 (0.262)	16.34 (3.22)	195 (91)	68 (20)	28.73 (97.29)
12th Gear									
372.10 (277.47)	20066 (89.26)	6.95 (11.18)	1800	2.3	0.431 (0.262)	16.35 (3.22)	196 (91)	68 (20)	28.73 (97.29)
13th Gear									
365.31 (272.41)	17746 (78.94)	7.72 (12.42)	1801	2.0	0.436 (0.265)	16.18 (3.19)	198 (92)	68 (20)	28.73 (97.29)
14th Gear									
370.40 (276.20)	16110 (71.66)	8.63 (13.88)	1800	1.8	0.431 (0.262)	16.37 (3.22)	200 (93)	67 (19)	28.73 (97.29)

Lugging ability in 11th gear

Crankshaft speed rpm	2100	2000	1898	1800	1700	1500	1300	1100
Pull-lbs (kN)	16201 (72.07)	19113 (85.02)	20982 (93.33)	22197 (98.74)	23438 (104.26)	24269 (107.95)	23421 (104.18)	22279 (99.10)
Increase in pull%	0	18	30	37	45	49	45	37
Power-Hp (kW)	316.13 (235.74)	354.91 (264.66)	367.54 (274.07)	368.52 (274.81)	367.35 (273.93)	335.07 (249.86)	280.21 (208.95)	225.91 (168.46)
Speed-mph (km/h)	7.32 (11.78)	6.96 (11.20)	6.57 (10.57)	6.23 (10.03)	5.88 (9.46)	5.18 (8.34)	4.49 (7.23)	3.80 (6.12)
Slip %	1.9	2.3	2.5	2.7	2.8	3.0	2.9	2.8

HYDRAULIC PERFORMANCE

CATEGORY: 4N/4

Quick Attach: Yes

OECD Static test

	<u>Category 4N</u>	<u>lift cylinders</u>
Maximum force exerted through whole range:	15694 lbs(69.8 kN) (1 x 90 mm and 1x100 mm)	
	20935 lbs(93.1kN) (2 x 110 mm)	
	<u>Category 4</u>	
	15959 lbs(71.0 kN) (1 x 90 mm and 1x100 mm)	
	21123 lbs(94.0 kN) (2 x 110 mm)	

18 Speed Powershift transmission

High flow pump Base pump three outlet sets combined

i) Sustained pressure at compensator cutoff:	2907 psi (200 bar)	2938 psi (203 bar)
ii) Pump delivery rate at minimum pressure and rated engine speed:	53.4 GPM(202.0 l/min)	32.0 GPM (121.1 l/min)
Combined flow:	85.4 GPM (323.1 l/min)	
iii) Pump delivery rate at maximum hydraulic power:	52.5 GPM(198.6 l/min)	31.5 GPM(119.2 l/min)
Delivery pressure:	2517 psi (173 bar)	2765 psi (191 bar)
Power:	77.0 HP (57.4 kW)	50.8 HP (37.9 kW)

single outlet set

i) Sustained pressure at compensator cutoff:	2903 psi (200 bar)	2938 psi (203 bar)
ii) Pump delivery rate at minimum pressure and rated engine speed:	38.1 GPM(144.1 l/min)	31.8 GPM(120.2 l/min)
iii) Pump delivery rate at maximum hydraulic power:	36.2 GPM(137.0 l/min)	31.5 GPM(119.2 l/min)
Delivery pressure:	2183 psi (150 bar)	2414 psi (166 bar)
Power:	46.1 HP (34.4 kW)	44.3 HP (33.1 kW)

24 speed manual shift transmission

three outlet sets combined

i) Sustained pressure at compensator cutoff:	2921 psi (201 bar)
ii) Pump delivery rate at minimum pressure and rated engine speed:	46.6 GPM(176.5 l/min)
iii) Pump delivery rate at maximum hydraulic power:	45.3 GPM(171.6 l/min)
Delivery pressure:	2602 psi (179 bar)
Power:	68.8 HP (51.3 kW)

single outlet set

i) Sustained pressure at compensator cutoff:	2931 psi (202 bar)
ii) Pump delivery rate at minimum pressure and rated engine speed:	36.2 GPM(136.9 l/min)
iii) Pump delivery rate at maximum hydraulic power:	35.4 GPM(133.9 l/min)
Delivery pressure:	2194 psi (151 bar)
Power:	45.3 HP (33.8 kW)

Category 4N

Category 4

	inch	mm	inch	mm
A	32.1	815	31.5	800
B	19.7	500	19.7	500
C	25.0	635	25.0	635
D	24.4	620	24.4	620
E	12.8	325	12.8	325
F	13.8	350	13.8	350
G	37.6	955	37.6	955
H	4.2	106	4.2	106
I	18.7	474	18.7	474
J	23.8	605	23.8	605
K	30.9	785	30.9	785
L	52.8	1342	52.8	1342
*L'	58.7	1491	59.6	1515
M	34.5	877	35.5	901
N	45.6	1159	45.6	1159
O	9.0	230	9.0	230
P	50.8	1290	50.8	1291
Q	39.4	1000	39.8	1010
R	48.2	1225	48.0	1220

*L' to Quick Attach ends

HITCH DIMENSIONS AS TESTED—NO LOAD

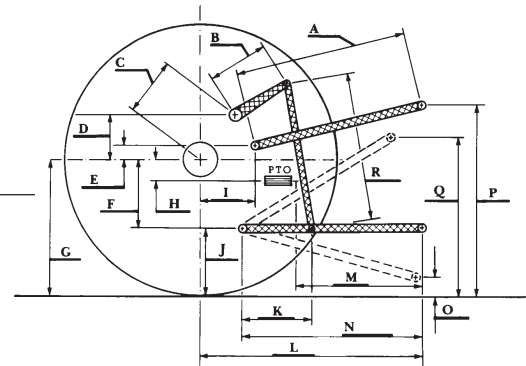

JOHN DEERE 9410R DIESEL