

NEBRASKA OECD TRACTOR TEST 2083-SUMMARY 932

JOHN DEERE 7290R IVT DIESEL INFINITELY VARIABLE TRANSMISSION

POWER TAKE-OFF PERFORMANCE

Power HP (kW)	Crank shaft speed rpm	Diesel Consumption		D.E.F. Consumption		Mean Atmospheric Conditions
		Gal/hr (l/h)	lb/hp.hr (kg/kW.h)	Hp.hr/gal (kW.h/l)	Gal/hr (l/h)	
MAXIMUM POWER AND FUEL CONSUMPTION						
Rated Engine Speed—(PTO speed—1077 rpm)						
245.99 (183.43)	2100	13.73 (51.97)	0.391 (0.238)	17.92 (3.53)	0.29 (1.08)	Fuel used during active exhaust regeneration-0.92 gal (3.48 l) (see note 1, p.2)
Standard Power Take-off Speed (1000 rpm)						
274.21 (204.48)	1950	14.76 (55.89)	0.377 (0.229)	18.57 (3.66)	0.33 (1.24)	
Maximum Power (1 hour)						
280.06 (208.84)	1751	14.70 (55.63)	0.367 (0.224)	19.06 (3.75)	0.33 (1.24)	

VARYING POWER AND FUEL CONSUMPTION

245.99 (183.43)	2100	13.73 (51.97)	0.391 (0.238)	17.92 (3.53)	0.29 (1.08)	Air temperature
214.67 (160.08)	2153	12.40 (46.96)	0.405 (0.246)	17.31 (3.41)	0.25 (0.96)	73°F (23°C)
161.54 (120.46)	2163	9.89 (37.45)	0.429 (0.261)	16.33 (3.22)	0.23 (0.87)	Relative humidity
108.52 (80.92)	2174	7.67 (29.03)	0.495 (0.301)	14.15 (2.79)	0.14 (0.55)	35%
54.30 (40.49)	2184	5.56 (21.06)	0.717 (0.436)	9.76 (1.92)	0.11 (0.40)	Barometer
0.67 (0.50)	2196	3.43 (12.98)	35.774 (21.761)	0.20 (0.04)	0.10 (0.39)	28.70" Hg (97.19 kPa)

Maximum torque - 896 lb.-ft. (1215 Nm) at 1500 rpm

Maximum torque rise - 45.8%

Torque rise at 1680 engine rpm - 40%

Power increase at 1751 engine rpm - 13.8%

DRAWBAR PERFORMANCE UNBALLASTED - FRONT DRIVE ENGAGED FUEL CONSUMPTION CHARACTERISTICS

Power Hp (kW)	Drawbar pull lbs (kN)	Speed mph (km/h)	Crank- shaft speed rpm	Slip %	Fuel Consumption lb/hp.hr (kg/kW.h)	Hp.hr/gal (kW.h/l)	Temp. °F (°C) cool- ing med	Air dry bulb	Barom. inch Hg (kPa)
Maximum Power—5.6 mph (9.0 km/h)-Manual mode									
211.58 (157.77)	14755 (65.63)	5.38 (8.66)	2100	2.6	0.451 (0.274)	15.52 (3.06)	217 (103)	53 (12)	28.69 (97.16)
75% of Pull at Maximum Power—5.6 mph (9.0 km/h)-Manual mode									
163.28 (121.76)	11010 (48.97)	5.56 (8.95)	2157	1.9	0.483 (0.294)	14.48 (2.85)	218 (103)	78 (26)	28.54 (96.65)
50% of Pull at Maximum Power—5.6 mph (9.0 km/h)-Manual mode									
110.80 (82.62)	7371 (32.79)	5.64 (9.08)	2169	1.1	0.547 (0.332)	12.81 (2.52)	217 (103)	79 (26)	28.53 (96.61)
75% of Pull at Reduced Engine Speed—5.6 mph (9.0 km/h)-Custom mode									
162.95 (121.51)	11020 (49.02)	5.55 (8.92)	1354	1.9	0.422 (0.257)	16.60 (3.27)	217 (103)	80 (27)	28.52 (96.58)
50% of Pull at Reduced Engine Speed—5.6 mph (9.0 km/h)-Custom mode									
109.89 (81.94)	7361 (32.74)	5.60 (9.00)	1092	1.1	0.439 (0.267)	15.96 (3.14)	215 (102)	79 (26)	28.51 (96.55)

Location of tests: Nebraska Tractor Test Laboratory, University of Nebraska, Lincoln, Nebraska 68583-0832

Dates of tests: April 7-22, 2014

Manufacturer: John Deere Tractor Works, 3500 East Donald Street, P.O. Box 270, Waterloo Ia, 50704-0270

CONSUMABLE Fluids, OIL and TIME: Fuel No. 2 Diesel **Specific gravity converted to 60°/60°F (15°/15°C)** 0.8410 **Fuel weight** 7.002 lbs/gal (0.839 kg/l) **Diesel Exhaust Fluid (DEF)** 32% aqueous urea solution **DEF weight** 9.071 lbs/gal (1.087 kg/l) **Oil** SAE 10W-30 **API service classification** CJ-4 **Transmission and hydraulic lubricant** John Deere Hy-Gard fluid **Front axle lubricant** John Deere Hy-Gard fluid **Total time engine was operated:** 40.0 hours

ENGINE: Make John Deere **Diesel Type** six cylinder vertical with two turbochargers, air to air aftercooler and D.E.F. (diesel exhaust fluid) exhaust treatment **Serial No.** *RG6090U000368* **Crankshaft** lengthwise **Rated engine speed** 2100 **Bore and stroke** 4.661 x 5.354" (118.4 mm x 136.0 mm) **Compression ratio** 16.0 to 1 **Displacement** 548 cu in (8984 ml) **Starting system** 12 volt **Lubrication** pressure **Air cleaner** two paper elements and aspirator **Oil filter** one full flow cartridge **Oil cooler** engine coolant heat exchanger for crankcase oil, radiator for hydraulic and transmission oil **Fuel filter** one paper element and prestrainer **Fuel cooler** radiator for pump return fuel **Exhaust** regenerative particulate filter integrated within a vertical muffler **Cooling medium temperature control** thermostat and variable speed fan

ENGINE OPERATING PARAMETERS: Fuel rate: 90.3 - 97.9 lb/h (41.0 - 44.4 kg/h) **High idle:** 2150 - 2250 rpm **Turbo boost:** nominal 21.8 - 25.4 psi (155 - 175 kPa) as measured 23.6 psi (163 kPa)

CHASSIS: Type front wheel assist with duals **Serial No.** *1RW7290RJE081004* **Tread width** rear 60.0" (1524 mm) to 128.9" (3272 mm) front 60.0" (1524 mm) to 88.0" (2235 mm) **Wheelbase** 115.2" (2925 mm) **Hydraulic control system** direct engine drive **Transmission** infinitely variable with two mechanical ranges and automatic shifting between ranges. **Nominal travel speeds mph (km/h)** forward - 0-25.0 mph (0-40 km/h), reverse - 0-12.4 mph (0-20 km/h) **Clutch** a foot pedal controls the hydrostatic oil flow **Brakes** wet multiple disc hydraulically operated by two foot pedals that can be locked together **Steering** hydrostatic **Power take-off** 540 rpm at 1958 engine rpm or 1000 rpm at 1958 engine rpm **Unladen tractor mass** 24280 lb (11013 kg)

DRAWBAR PERFORMANCE
UNBALLASTED - FRONT DRIVE ENGAGED

MANUAL MODE-2100 ENGINE RPM
DRAWBAR POWER AT SELECTED TRAVEL SPEED SETTINGS

Power Hp (kW)	Drawbar pull lbs (kN)	Speed mph (km/h)	Crank- shaft speed rpm	Slip %	Fuel Consumption lb/hp.hr (kg/kW.h)	Temp. °F (°C) cool- ing med	Air dry bulb	Barom. inch Hg (kPa)	
				3.0 mph (4.8 km/h)					
169.87 (126.67)	24028 (106.88)	2.66 (4.27)	2154	12.5	0.510 (0.310)	13.73 (2.70)	218 (103)	55 (13)	28.79 (97.49)
				3.9 mph (6.4 km/h)					
205.95 (153.58)	21016 (93.48)	3.68 (5.91)	2102	6.4	0.463 (0.282)	15.12 (2.98)	218 (103)	55 (13)	28.65 (97.02)
				4.3 mph (7.0 km/h)					
209.40 (156.15)	19182 (85.32)	4.09 (6.58)	2100	4.7	0.455 (0.277)	15.38 (3.03)	218 (103)	56 (13)	28.66 (97.05)
				4.7 mph (7.6 km/h)					
207.29 (154.58)	17311 (77.00)	4.50 (7.23)	2100	3.6	0.461 (0.281)	15.18 (2.99)	218 (103)	73 (23)	28.58 (96.78)
				5.1 mph (8.2 km/h)					
208.51 (155.49)	16031 (71.31)	4.88 (7.85)	2100	3.1	0.457 (0.278)	15.32 (3.02)	218 (103)	70 (21)	28.60 (96.85)
				5.6 mph (9.0 km/h)					
211.58 (157.77)	14755 (65.63)	5.38 (8.66)	2100	2.6	0.451 (0.274)	15.52 (3.06)	217 (103)	53 (12)	28.69 (97.16)
				6.2 mph (10.0 km/h)					
206.36 (153.88)	12892 (57.35)	6.01 (9.66)	2100	2.2	0.462 (0.281)	15.16 (2.99)	218 (103)	60 (16)	28.67 (97.09)
				6.8 mph (11.0 km/h)					
208.67 (155.60)	12020 (53.47)	6.51 (10.48)	2100	2.0	0.457 (0.278)	15.31 (3.02)	218 (103)	62 (17)	28.66 (97.05)
				7.5 mph (12.0 km/h)					
211.82 (157.95)	10853 (48.28)	7.32 (11.78)	2100	1.8	0.451 (0.275)	15.51 (3.06)	218 (103)	67 (19)	28.63 (96.95)
				8.1 mph (13.0 km/h)					
212.08 (158.14)	10140 (45.10)	7.84 (12.62)	2100	1.6	0.450 (0.274)	15.57 (3.07)	218 (103)	68 (20)	28.63 (96.95)
				8.7 mph (14.0 km/h)					
212.93 (158.78)	9550 (42.48)	8.36 (13.45)	2100	1.4	0.450 (0.273)	15.58 (3.07)	218 (103)	71 (22)	28.61 (96.88)

TRACTOR SOUND LEVEL WITH CAB	Front Wheel Drive	
	Engaged dB(A)	Disengaged dB(A)
At no load at 4.6 mph (7.5 km/h) engine speed - 2190 rpm	69.3	69.2
At no load at 4.6 mph (7.5 km/h) engine speed - 1200 rpm	64.4	64.5
Transport speed - no load - manual mode		71.6
Transport speed - no load - Full Automode		70.7
Bystander		84.5

TIRES, BALLAST AND WEIGHT

	With Ballast	Without Ballast
Rear Tires - No., size, ply & psi (kPa)	Four 480/80R46;***;16(110)	Four 480/80R46;***;12(85)
Ballast - Liquid (total)	None	None
- Cast Iron (total)	3910 lb (1774 kg)	None
Front Tires - No., size, ply & psi (kPa)	Two 420/90R30;***;23(160)	Two 420/90R30;***;16(110)
Ballast - Liquid (total)	None	None
- Cast Iron (total)	2360 lb (1070 kg)	None
Height of Drawbar	18.5 in (470 mm)	18.5 in (470 mm)
Static Weight with operator - Rear	19185 lb (8702 kg)	16005 lb (7260 kg)
- Front	11540 lb (5235 kg)	8450 lb (3833 kg)
- Total	30725 lb (13937 kg)	24455 lb (11093 kg)

REPAIRS AND ADJUSTMENTS: No repairs or adjustments.

NOTE 1: The manufacturer declares that the average time between active regenerations is 50 hours, while operated in Auto Filter Cleaning Mode, at rated speed, full load, under steady state conditions. A 2% power loss was observed during the active regeneration.

REMARKS: All test results were determined from observed data obtained in accordance with official OECD, SAE and Nebraska test procedures. For the maximum power tests the fuel temperature at the injection pump inlet was maintained at 126°F (52°C). This tractor did not meet the manufacturer's remote hydraulic flow claim of 59 GPM (223.3 l/min) with the 85 cc pump. The performance figures on this summary were taken from a test conducted under the OECD Code 2 test procedure.

We, the undersigned, certify that this is a true and correct report of official Tractor Test No. **2083**, Nebraska Summary 932, May 15, 2014.

Roger M. Hoy
Director

M.F. Kocher
J.D. Luck
P.J. Jasa
Board of Tractor Test Engineers

DRAWBAR PERFORMANCE
UNBALLASTED - FRONT DRIVE ENGAGED - AUTO MODE
(Loads based on 2100 engine rpm manual mode performance runs)
DRAWBAR POWER AT SELECTED TRAVEL SPEED SETTINGS

Power Hp (kW)	Drawbar pull lbs (kN)	Speed mph (km/h)	Crank- shaft speed rpm	Slip %	Fuel Consumption lb/hp.hr (kg/kW.h)	Fuel Consumption Hp.hr/gal (kW.h/l)	Temp. °F(°C) cool- ing med	Air dry bulb	Barom. inch Hg (kPa)
166.05 (123.82)	23898 (106.30)	2.61 (4.20)	1688	14.2	0.477 (0.290)	14.69 (2.89)	217 (103)	56 (14)	28.79 (97.49)
206.33 (153.86)	21210 (94.35)	3.65 (5.87)	1848	6.5	0.440 (0.268)	15.90 (3.13)	217 (103)	57 (14)	28.66 (97.05)
208.29 (155.32)	19104 (84.98)	4.09 (6.58)	1850	4.5	0.436 (0.265)	16.05 (3.16)	218 (103)	56 (13)	28.67 (97.08)
206.10 (153.69)	17264 (76.79)	4.48 (7.20)	1850	3.6	0.440 (0.268)	15.92 (3.14)	218 (103)	74 (23)	28.58 (96.78)
207.87 (155.00)	15998 (71.16)	4.88 (7.85)	1850	3.1	0.438 (0.267)	15.97 (3.15)	218 (103)	72 (22)	28.59 (96.82)
210.64 (157.07)	14706 (65.41)	5.37 (8.64)	1850	2.7	0.436 (0.265)	16.06 (3.16)	218 (103)	58 (15)	28.69 (97.16)
207.20 (154.51)	12855 (57.18)	6.05 (9.73)	1850	2.2	0.434 (0.264)	16.14 (3.18)	217 (103)	61 (16)	28.66 (97.05)
208.15 (155.22)	12014 (53.44)	6.50 (10.45)	1850	2.0	0.429 (0.261)	16.33 (3.22)	217 (103)	63 (17)	28.65 (97.02)
211.86 (157.98)	10820 (48.13)	7.34 (11.81)	1850	1.8	0.428 (0.260)	16.35 (3.22)	217 (103)	68 (20)	28.63 (96.95)
213.53 (159.23)	10151 (45.15)	7.89 (12.70)	1850	1.6	0.425 (0.258)	16.48 (3.25)	218 (103)	70 (21)	28.62 (96.92)
214.94 (160.28)	9514 (42.32)	8.47 (13.63)	1850	1.5	0.424 (0.258)	16.51 (3.25)	218 (103)	71 (22)	28.61 (96.88)

DRAWBAR PERFORMANCE
UNBALLASTED - FRONT DRIVE ENGAGED - 1750 RPM
MAXIMUM POWER AT SELECTED TRAVEL SPEED SETTINGS

Power Hp (kW)	Drawbar pull lbs (kN)	Speed mph (km/h)	Crank- shaft speed rpm	Slip %	Fuel Consumption		Temp. °F(°C)		Barom. inch Hg (kPa)
					lb/hp.hr (kg/kW.h)	Hp.hr/gal (kW.h/l)	cool- ing med	Air dry bulb	
					3.0 mph (4.8 km/h)				
169.98 (126.75)	24047 (106.97)	2.66 (4.27)	2154	12.5	0.510 (0.310)	13.74 (2.71)	218 (103)	55 (13)	28.78 (97.46)
					3.9 mph (6.4 km/h)				
205.81 (153.47)	21078 (93.76)	3.66 (5.89)	2100	6.6	0.464 (0.282)	15.11 (2.98)	218 (103)	55 (13)	28.65 (97.02)
					4.3 mph (7.0 km/h)				
216.57 (161.50)	20601 (91.64)	3.95 (6.35)	2044	5.5	0.452 (0.275)	15.49 (3.05)	218 (103)	57 (14)	28.66 (97.05)
					4.7 mph (7.6 km/h)				
229.90 (171.43)	20404 (90.76)	4.23 (6.80)	1986	5.1	0.444 (0.270)	15.76 (3.11)	219 (104)	57 (14)	28.67 (97.09)
					5.1 mph (8.2 km/h)				
234.77 (175.07)	20056 (89.21)	4.39 (7.07)	1909	4.9	0.439 (0.267)	15.97 (3.15)	219 (104)	58 (14)	28.68 (97.12)
					5.6 mph (9.0 km/h)				
237.69 (177.24)	19775 (87.96)	4.51 (7.26)	1780	4.8	0.432 (0.263)	16.21 (3.19)	218 (103)	59 (15)	28.68 (97.12)
					6.2 mph (10.0 km/h)				
237.35 (176.99)	17923 (79.73)	4.97 (7.99)	1750	3.8	0.431 (0.262)	16.23 (3.20)	218 (103)	59 (15)	28.69 (97.16)
					6.8 mph (11.0 km/h)				
241.31 (179.94)	16558 (73.65)	5.47 (8.80)	1750	3.4	0.424 (0.258)	16.51 (3.25)	218 (103)	60 (15)	28.70 (97.19)
					7.5 mph (12.0 km/h)				
243.32 (181.44)	15166 (67.46)	6.02 (9.68)	1750	3.0	0.420 (0.255)	16.67 (3.28)	218 (103)	60 (16)	28.71 (97.22)
					8.1 mph (13.0 km/h)				
245.08 (182.75)	14365 (63.90)	6.40 (10.30)	1751	2.8	0.418 (0.254)	16.76 (3.30)	218 (103)	60 (16)	28.71 (97.22)
					8.7 mph (14.0 km/h)				
246.67 (183.94)	13279 (59.07)	6.97 (11.21)	1750	2.5	0.415 (0.252)	16.88 (3.32)	218 (103)	60 (16)	28.71 (97.22)
					9.4 mph (15.2 km/h)				
247.72 (184.72)	12269 (54.58)	7.57 (12.18)	1750	2.2	0.413 (0.251)	16.94 (3.34)	219 (104)	59 (15)	28.71 (97.22)
					10.2 mph (16.4 km/h)				
248.55 (185.34)	11231 (49.96)	8.30 (13.36)	1751	2.0	0.412 (0.250)	17.01 (3.35)	218 (103)	60 (15)	28.70 (97.19)

DRAWBAR PERFORMANCE
BALLASTED - FRONT DRIVE ENGAGED - 1750 RPM
MAXIMUM POWER AT SELECTED TRAVEL SPEED SETTINGS

Power Hp (kW)	Drawbar pull lbs (kN)	Speed mph (km/h)	Crank- shaft speed rpm	Slip %	Fuel Consumption lb/hp.hr (kg/kW.h)	Temp. °F(°C) cool- ing med	Air dry bulb	Barom. inch Hg (kPa)	
2.7 mph (4.4 km/h)									
179.00 (133.48)	28363 (126.16)	2.37 (3.81)	2140	14.1	0.516 (0.314)	13.57 (2.67)	217 (103)	56 (13)	28.75 (97.36)
3.2 mph (5.2 km/h)									
206.04 (153.64)	27198 (120.98)	2.85 (4.58)	2064	9.6	0.471 (0.287)	14.86 (2.93)	217 (103)	47 (8)	28.87 (97.77)
4.0 mph (6.4 km/h)									
230.75 (172.07)	26442 (117.62)	3.28 (5.27)	1900	8.1	0.448 (0.272)	15.64 (3.08)	217 (103)	47 (8)	28.87 (97.77)
4.3 mph (7.0 km/h)									
234.76 (175.06)	25621 (113.97)	3.44 (5.54)	1808	6.9	0.437 (0.266)	16.03 (3.16)	218 (103)	49 (9)	28.84 (97.66)
4.7 mph (7.6 km/h)									
238.48 (177.83)	24374 (108.42)	3.67 (5.91)	1750	5.9	0.430 (0.261)	16.30 (3.21)	217 (103)	49 (9)	28.83 (97.63)
5.1 mph (8.2 km/h)									
240.78 (179.55)	22632 (100.67)	3.99 (6.42)	1750	4.8	0.425 (0.259)	16.46 (3.24)	217 (103)	51 (10)	28.83 (97.63)
5.6 mph (9.0 km/h)									
242.06 (180.50)	20021 (89.06)	4.54 (7.30)	1750	3.9	0.423 (0.257)	16.55 (3.26)	218 (103)	51 (11)	28.81 (97.56)
6.2 mph (10.0 km/h)									
240.20 (179.11)	18221 (81.05)	4.94 (7.95)	1750	3.3	0.426 (0.259)	16.42 (3.24)	218 (103)	52 (11)	28.80 (97.53)
6.8 mph (11.0 km/h)									
243.35 (181.46)	16743 (74.48)	5.45 (8.77)	1750	2.9	0.420 (0.256)	16.66 (3.28)	218 (103)	52 (11)	28.80 (97.53)
7.5 mph (12.0 km/h)									
245.92 (183.38)	15613 (69.45)	5.91 (9.51)	1751	2.6	0.416 (0.253)	16.83 (3.31)	218 (103)	53 (11)	28.80 (97.53)
8.1 mph (13.0 km/h)									
246.96 (184.16)	14561 (64.77)	6.36 (10.24)	1750	2.3	0.415 (0.253)	16.85 (3.32)	218 (103)	52 (11)	28.79 (97.49)
8.7 mph (14.0 km/h)									
248.63 (185.40)	13360 (59.43)	6.98 (11.23)	1749	2.1	0.411 (0.250)	17.04 (3.36)	218 (103)	54 (12)	28.77 (97.43)
9.4 mph (15.2 km/h)									
249.29 (185.90)	12418 (55.24)	7.53 (12.12)	1750	1.9	0.410 (0.250)	17.07 (3.36)	218 (103)	55 (13)	28.78 (97.46)
10.2 mph (16.4 km/h)									
249.78 (186.26)	11372 (50.59)	8.24 (13.26)	1750	1.7	0.409 (0.249)	17.11 (3.37)	218 (103)	55 (13)	28.77 (97.43)

HYDRAULIC PERFORMANCE

CATEGORY: III

Quick Attach: Yes

OECD Static test

	<u>lift cylinders</u>	
Maximum force exerted through whole range:	15862 lbs (70.6 kN) (2x100 mm)	18302 lbs (81.4 kN) (1x100 mm & 1x115 mm)
	<u>63 cc pump</u> <u>85 cc pump</u>	
i) Sustained pressure at compensator cutoff:	2955 psi (204 bar)	2931 psi (202 bar)
	<u>three outlet sets combined</u>	
ii) Pump delivery rate at minimum pressure and rated engine speed:	44.4 GPM (168.1 l/min)	58.3 GPM (220.7 l/min)
iii) Pump delivery rate at maximum hydraulic power:	43.3 GPM (164.0 l/min)	57.5 GPM (217.6 l/min)
Delivery pressure:	2761 psi (190 bar)	2571 psi (177 bar)
Power:	69.8 HP (52.0 kW)	86.2 HP (64.3 kW)
	<u>single outlet set</u>	
ii) Pump delivery rate at minimum pressure and rated engine speed:	36.1 GPM (136.5 l/min)	36.4 GPM (137.9 l/min)
iii) Pump delivery rate at maximum hydraulic power:	35.5 GPM (134.5 l/min)	35.4 GPM (134.0 l/min)
Delivery pressure:	2298 psi (158 bar)	2244 psi (155 bar)
Power:	47.6 HP (35.5 kW)	46.4 HP (34.6 kW)

HITCH DIMENSIONS AS TESTED—NO LOAD

	inch	mm
A	28.0	710
B	20.5	520
C	22.9	581
D	18.9	480
E	7.3	185
F	14.4	365
G	38.8	985
H	3.5	90
I	22.4	570
J	24.4	620
K	29.3	745
L	52.0	1321
*L'	56.0	1423
M	28.0	712
N	43.4	1102
O	9.0	230
P	51.9	1319
Q	39.4	1001
R	44.9	1140

*L' to Quick Attach ends

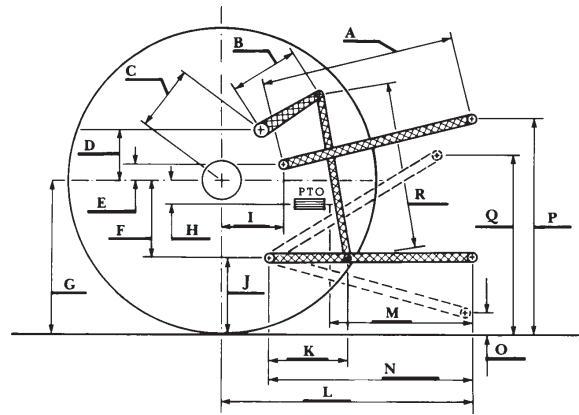

JOHN DEERE 7290R DIESEL

Institute of Agriculture and Natural Resources
University of Nebraska-Lincoln