

NEBRASKA TRACTOR TEST 1917

FARMTRAC 675 DTC DIESEL

ALSO FARMTRAC 8075 DIESEL

12 SPEED

POWER TAKE-OFF PERFORMANCE

Power HP (kW)	Crank shaft speed rpm	Gal/hr (l/h)	lb/hp.hr (kg/kW.h)	Hp.hr/gal (kW.h/l)	Mean Atmospheric Conditions
---------------------	--------------------------------	-----------------	-----------------------	-----------------------	--------------------------------

MAXIMUM POWER AND FUEL CONSUMPTION

Rated Engine Speed—(PTO speed—562 rpm)					
67.13 (50.06)	2201	4.61 (17.44)	0.481 (0.293)	14.57 (2.87)	
Standard Power Take-off Speed - (539 rpm)					
66.71 (49.75)	2112	4.53 (17.15)	0.476 (0.289)	14.72 (2.90)	

VARYING POWER AND FUEL CONSUMPTION

67.13 (50.06)	2201	4.61 (17.44)	0.481 (0.293)	14.57 (2.87)	Air temperature
61.19 (45.63)	2362	4.34 (16.42)	0.497 (0.302)	14.11 (2.78)	76°F (24°C)
46.38 (34.59)	2386	3.47 (13.13)	0.524 (0.319)	13.38 (2.64)	Relative humidity
31.35 (23.38)	2412	2.71 (10.26)	0.606 (0.369)	11.56 (2.28)	11%
15.70 (11.70)	2433	2.00 (7.56)	0.892 (0.543)	7.86 (1.55)	Barometer
0.83 (0.62)	2453	1.43 (5.40)	11.986 (7.291)	0.58 (0.12)	28.93"Hg (97.97kPa)

Maximum torque 199 lb.-ft. (270 Nm) at 1101 rpm
 Maximum torque rise - 24.3%
 Torque rise at 1800 rpm - 13%

TRACTOR SOUND LEVEL WITHOUT CAB

	Front Wheel Drive	
	Engaged dB(A)	Disengaged dB(A)
At no load in 7th(M3) gear	92.8	92.9
Bystander	--	--

TIRES AND WEIGHT

Rear Tires—No., size, ply & psi (kPa)
Front Tires—No., size, ply & psi (kPa)
Height of Drawbar
Static Weight with operator—Rear
 —Front
 —Total

Tested without ballast

Two 16.9-30; 6; 14 (95)
 Two 11.2-24; 4; 14 (95)
 16.0 in (405 mm)
 3540 lb (1606 kg)
 2750 lb (1247 kg)
 6290 lb (2853 kg)

Location of tests: Nebraska Tractor Test Laboratory, University of Nebraska, Lincoln Nebraska 68583-0832

Dates of tests: March 3 - July 9, 2008

Manufacturer: Escorts Limited, Agri Machinery Group Plant 1, 18/4 Mathura Road, Faridabad - 12007 India

FUEL, OIL and TIME: Fuel No. 2 Diesel Specific gravity converted to 60°/60° F (15°/15°C) 0.8417 Fuel weight 7.008 lbs/gal (0.840 kg/l) Oil SAE 15W40 API service classification CF-4 Transmission and hydraulic lubricant SAE 80W90 gear lube Front axle lubricant SAE 80W90 gear lube Total time engine was operated 11.5 hours

ENGINE: Make Perkins Diesel Type four cylinder vertical Serial No. S38189*U325253N* Crankshaft lengthwise Rated engine speed 2200 Bore and stroke 4.134" x 5.00" (105.0 mm x 127.0 mm) Compression ratio 19.3 to 1 Displacement 268 cu in (4400 ml) Starting system 12 volt Lubrication pressure Air cleaner two paper elements Oil filter one full flow cartridge Fuel filter one paper element and water separator Oil cooler radiator for hydraulic and transmission oil Muffler vertical Cooling medium temperature control one thermostat

ENGINE OPERATING PARAMETERS: Fuel rate: 29.4 - 32.4 lb/h (13.3 - 14.7 kg/h) High idle: 2360 - 2460 rpm

CHASSIS: Type Front wheel assist Serial No. T2081571 Tread width rear 57.5" (1460 mm) to 73.2" (1860 mm) front 59.4" (1508 mm) to 75.1" (1908 mm) Wheelbase 80.7" (2050 mm) Hydraulic control system direct engine drive Transmission selective gear fixed ratio Nominal travel speeds mph (km/h) first 0.89 (1.43) second 1.32 (2.12) third 1.93 (3.11) fourth 2.26 (3.64) fifth 2.72 (4.37) sixth 3.35 (5.39) seventh 4.90 (7.89) eighth 6.00 (9.65) ninth 6.89 (11.08) tenth 8.88 (14.29) eleventh 12.99 (20.91) twelfth 18.26 (29.39) reverse 0.75 (1.20), 1.11 (1.78), 1.62 (2.61), 1.90, (3.05), 2.27, (3.66), 2.81 (4.52), 4.11 (6.61), 5.03 (8.10) 5.77, (9.29), 7.45 (11.99), 10.90 (17.54), 15.32 (24.65) Clutch single dry disc operated by foot pedal Brakes multiple wet disc hydraulically operated by two foot pedals which can be locked together Steering hydrostatic Power take-off 540 rpm at 2115 engine rpm Unladen tractor mass 6115 lb (2774 kg)

THREE POINT HITCH PERFORMANCE (OECD Static Test)

CATEGORY: II
 Quick Attach: None
 Maximum force exerted through whole range: 3978 lbs (17.7 kN) (at 24" point)
 5063 lbs (22.5 kN) (at hitch points)
 3057 psi (211 bar)

i) Sustained pressure of the open relief valve: 3057 psi (211 bar)

ii) Pump delivery rate at minimum pressure and rated engine speed: 9.8 GPM (37.0 l/min)

iii) Pump delivery rate at maximum hydraulic power: 9.1 GPM (34.4 l/min)
 Delivery pressure: 2920 psi (201 bar)
 Power: 15.5 HP (11.5 kW)

THREE POINT HITCH PERFORMANCE

Observed maximum pressure psi.(bar) 3050(211)
 Location: remote outlet
 Hydraulic oil temperature: °F(°C) 140(60)
 Location: hydraulic sump
 Category: II
 Quick attach: none

SAE Static Test—System pressure 2550 psi (176 Bar)

Hitch point distance to ground level in.(mm)	8.0(203)	15.0(381)	22.0(559)	29.0(737)	35.0(889)
Lift force on frame lb	5802	5401	5255	5000	4557
" " " " " (kN)	(25.8)	(24.0)	(23.4)	(22.2)	(20.3)

REPAIRS AND ADJUSTMENTS: No repairs or adjustments.

REMARKS: All test results were determined from observed data obtained in accordance with official OECD, SAE and Nebraska test procedures. This tractor did not meet the manufacturer's claims of 11.0 GPM remote hydraulic flow nor 5280 lbs lift at the hitch points. For the maximum power tests, the fuel temperature at the fuel filter was maintained at 140°F (60°C).

We, the undersigned, certify that this is a true and correct report of official Tractor Test No. **1917**, September 17, 2008.

Roger M. Hoy
 Director

M.F. Kocher
 V.I Adamchuk
 J.A. Smith
 Board of Tractor Test Engineers

	SAE test		OECD test	
	inch	mm	inch	mm
A	29.6	752	29.8	757
B	10.6	270	10.6	270
C	12.2	310	12.2	310
D	12.2	310	12.2	310
E	12.9	327	12.9	327
F	7.6	192	7.6	192
G	27.4	695	27.4	695
H	0.0	0.0	0.0	0.0
I	8.9	225	8.9	225
J	19.8	503	19.8	503
K	23.2	590	23.2	590
L	39.1	992	39.1	992
M	23.3	592	23.3	592
N	36.2	920	36.2	920
O	8.0	203	8.0	203
P	38.8	986	43.8	1113
Q	33.2	843	33.2	843
R	23.9	606	23.9	606

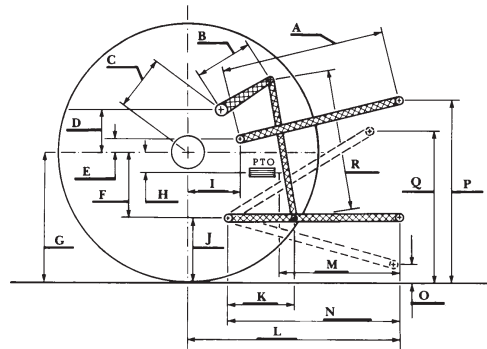

HITCH DIMENSIONS AS TESTED - NO LOAD



FARMTRAC 675 DTC Diesel

Institute of Agriculture and Natural Resources
 University of Nebraska-Lincoln