

NEBRASKA OECD TRACTOR TEST 1972-SUMMARY 733

JOHN DEERE 8345R DIESEL

INFINITELY VARIABLE TRANSMISSION

POWER TAKE-OFF PERFORMANCE

Power HP (kW)	Crank shaft speed rpm	Gal/hr (l/h)	lb/hp.hr (kg/kW.h)	Hp.hr/gal (kW.h/l)	Mean Atmospheric Conditions
MAXIMUM POWER AND FUEL CONSUMPTION					
Rated Engine Speed—(PTO speed—1051 rpm)					
285.49 (212.89)	2102	15.57 (58.93)	0.383 (0.233)	18.34 (3.61)	
Standard Power Take-off Speed(1000 rpm)					
313.52 (233.79)	2000	16.90 (63.97)	0.378 (0.230)	18.55 (3.65)	
Maximum Power (1 hour)					
325.01 (242.36)	1802	17.31 (65.54)	0.374 (0.228)	18.77 (3.70)	

VARYING POWER AND FUEL CONSUMPTION

285.49 (212.89)	2102	15.57 (58.93)	0.383 (0.233)	18.34 (3.61)	Air temperature
248.54 (185.33)	2153	14.17 (53.65)	0.400 (0.244)	17.54 (3.45)	73°F (23°C)
187.22 (139.61)	2163	11.50 (43.52)	0.431 (0.262)	16.28 (3.21)	Relative humidity
125.44 (93.54)	2174	8.68 (32.86)	0.486 (0.296)	14.45 (2.85)	33%
63.00 (46.98)	2184	6.35 (24.02)	0.707 (0.431)	9.93 (1.96)	Barometer
1.98 (1.48)	2195	4.17 (15.77)	14.765 (8.981)	0.48 (0.09)	28.78" Hg (97.46 kPa)

Maximum Torque - 1053 lb.-ft. (1428 Nm) at 1496 rpm
 Maximum Torque Rise - 47.7%
 Torque rise at 1698 engine rpm - 39%
 Power increase at 1802 rpm - 13.8%

DRAWBAR PERFORMANCE

UNBALLASTED - FRONT DRIVE ENGAGED

FUEL CONSUMPTION CHARACTERISTICS

Power Hp (kW)	Drawbar pull lbs (kN)	Speed mph (km/h)	Crank- shaft speed rpm	Slip %	Fuel Consumption lb/hp.hr (kg/kW.h)	Hp.hr/gal (kW.h/l)	Temp.°F (°C) cool- ing dry bulb	Barom. inch Hg (kPa)
Maximum Power—5.6 mph (9.0 km/h)								
249.74 (186.23)	17899 (79.62)	5.24 (8.42)	2098	4.3	0.435 (0.265)	16.14 (3.18)	204 (96)	58 (14)
75% of Pull at Maximum Power—5.6 mph (9.0 km/h)								
193.53 (144.31)	13370 (59.47)	5.43 (8.74)	2157	3.2	0.473 (0.288)	14.84 (2.92)	202 (95)	69 (21)
50% of Pull at Maximum Power—5.6 mph (9.0 km/h)								
130.82 (97.55)	8892 (39.55)	5.52 (8.88)	2169	2.3	0.527 (0.321)	13.32 (2.62)	186 (85)	69 (21)
75% of Pull at Reduced Engine Speed—Automode								
193.36 (144.19)	13412 (59.66)	5.41 (8.70)	1727	3.3	0.451 (0.275)	15.56 (3.07)	203 (95)	69 (21)
50% of Pull at Reduced Engine Speed—Automode								
131.10 (97.76)	8994 (40.01)	5.47 (8.80)	1372	2.4	0.447 (0.272)	15.72 (3.10)	201 (94)	70 (21)

Location of tests: Nebraska Tractor Test Laboratory, University of Nebraska, Lincoln, Nebraska 68583-0832

Dates of tests: May 11 - June 4, 2010

Manufacturer: John Deere Tractor Works, 3500 East Donald St., P.O. Box 270, Waterloo Ia, 50704-0270

FUEL, OIL and TIME: Fuel No. 2 Diesel Specific gravity converted to 60°/60°F (15°/15°C) 0.8433 Fuel weight 7.022 lbs/gal (0.842 kg/l) Oil SAE 15W-40 API service classification CI-4 Transmission and hydraulic lubricant John Deere Hy-Gard fluid Front axle lubricant John Deere Hy-Gard fluid Total time engine was operated: 40.5 hours

ENGINE: Make John Deere Diesel **Type** six cylinder vertical with turbocharger and air to air aftercooler **Serial No.** *RG6090L069070* **Crankshaft** lengthwise **Rated engine speed** 2100 **Bore and stroke** 4.661" x 5.354" (118.4 mm x 136.0 mm) **Compression ratio** 16.3 to 1 **Displacement** 548 cu in (8984 ml) **Starting system** 12 volt **Lubrication** pressure **Air cleaner** two paper elements and aspirator **Oil filter** one full flow cartridge **Oil cooler** engine coolant heat exchanger for crankcase oil, radiator for hydraulic and transmission oil **Fuel filter** one paper element and water separator **Fuel cooler** radiator for pump return fuel **Muffler** vertical **Cooling medium temperature control** 2 thermostats and variable speed fan

ENGINE OPERATING PARAMETERS: Fuel rate: 108.2 - 117.1 lb/h (49.1 - 53.1 kg/h) **High idle:** 2175 - 2225 rpm **Turbo boost:** nominal 28.3 - 32.6 psi (195 - 225 kPa) as measured 29.5 psi (203 kPa)

CHASSIS: Type front wheel assist with duals **Serial No.** *1RW8345RA9D003572* **Tread width** rear 60.0" (1524 mm) to 128.9" (3270 mm) front 64.0" (1625 mm) to 87.6" (2225 mm) **Wheelbase** 118.9" (3020 mm) **Hydraulic control system** direct engine drive **Transmission** Infinitely variable with four mechanical ranges and automatic shifting between ranges. **Nominal travel speeds mph (km/h)** forward - 0 - 26.1 mph, (0 - 42 km/h) reverse - 0 - 12.4 mph (0-20 km/h) **Clutch** a foot pedal controls the hydrostatic oil flow **Brakes** wet multiple disc hydraulically operated by two foot pedals that can be locked together **Steering** hydrostatic **Power take-off** 1000 rpm at 2000 engine rpm **Unladen tractor mass** 27060 lb (12274 kg)

DRAWBAR PERFORMANCE
UNBALLASTED - FRONT DRIVE ENGAGED - 2100 RPM
MAXIMUM POWER AT SELECTED SPEED SETTINGS

Power Hp (kW)	Drawbar pull lbs (kN)	Speed mph (km/h)	Crank- shaft speed rpm	Slip %	Fuel Consumption lb/hp.hr (kg/kW.h)	Hp.hr/gal (kW.h/l)	Temp. °F (°C) cool- ing med	Air dry bulb	Barom. inch Hg (kPa)
223.11 (166.37)	27038 (120.27)	3.10 (4.98)	2124	11.0	0.477 (0.290)	14.73 (2.90)	196 (91)	52 (11)	28.92 (97.93)
239.66 (178.71)	24947 (110.97)	3.61 (5.80)	2102	7.9	0.454 (0.276)	15.48 (3.05)	203 (95)	58 (14)	28.92 (97.93)
245.76 (183.26)	23219 (103.28)	3.97 (6.39)	2097	6.7	0.441 (0.268)	15.92 (3.14)	204 (95)	61 (16)	28.92 (97.93)
246.54 (183.84)	21274 (94.63)	4.35 (6.99)	2097	5.9	0.440 (0.268)	15.95 (3.14)	202 (94)	61 (16)	28.95 (98.04)
248.03 (184.95)	19654 (87.43)	4.73 (7.61)	2101	5.0	0.436 (0.265)	16.11 (3.17)	202 (94)	62 (17)	28.95 (98.04)
249.74 (186.23)	17899 (79.62)	5.24 (8.42)	2098	4.3	0.435 (0.265)	16.14 (3.18)	204 (96)	58 (14)	28.94 (98.00)
250.18 (186.56)	16073 (71.50)	5.84 (9.40)	2098	4.1	0.433 (0.263)	16.22 (3.19)	202 (94)	59 (15)	28.94 (98.00)
247.57 (184.61)	14410 (64.10)	6.45 (10.37)	2099	3.4	0.437 (0.266)	16.07 (3.17)	202 (95)	60 (16)	28.95 (98.04)
247.40 (184.49)	13116 (58.34)	7.08 (11.39)	2098	2.8	0.440 (0.268)	15.96 (3.14)	202 (94)	57 (14)	28.93 (97.97)
244.16 (182.07)	11962 (53.21)	7.66 (12.32)	2099	2.6	0.445 (0.271)	15.79 (3.11)	203 (95)	63 (17)	28.96 (98.07)
244.40 (182.25)	11078 (49.28)	8.28 (13.32)	2098	2.4	0.441 (0.269)	15.91 (3.13)	202 (94)	63 (17)	28.96 (98.07)

REPAIRS AND ADJUSTMENTS: No repairs or adjustments.

NOTE: Manual mode was selected by placing the AutoPowr(IVT) selector in the OFF position. Auto mode was selected by placing the Autopowr (IVT) selector in position 3.

REMARKS: All test results were determined from observed data obtained in accordance with official OECD, SAE and Nebraska test procedures. For the maximum power tests the fuel temperature at the injection pump inlet was maintained at 115°F(46 °C). The performance figures on this summary were taken from a test conducted under the OECD Code 2 test code procedure.

We, the undersigned, certify that this is a true and correct report of official Tractor Test No. **1972**, Nebraska Summary 733, July 27, 2010.

Roger M. Hoy
Director

M.F. Kocher
D.R. Keshwani
J.A. Smith
Board of Tractor Test Engineers

TRACTOR SOUND LEVEL WITH CAB	Front Wheel Drive	
	Engaged dB(A)	Disengaged dB(A)
At no load at 4.6 mph (7.5 km/h) engine speed - 2190 rpm	71.4	71.1
At no load at 4.6 mph (7.5 km/h) engine speed - 1400 rpm	66.9	66.6
Transport speed - no load - manual mode		73.6
Transport speed - no load - Automode 3		71.9
Bystander		85.6

TIRES, BALLAST AND WEIGHT

	With Ballast	Without Ballast
Rear Tires - No., size, ply & psi(kPa)	Six 480/80R50;***;12(85)	Four 480/80R50;***;12(85)
Ballast - Triples (total)	2420 lb (1098 kg)	None
- Cast Iron (total)	6325 lb (2869 kg)	None
Front Tires - No., size, ply & psi(kPa)	Four 420/85R34;***;16(110)	Two 420/85R34;***;23(160)
Ballast - Duals (total)	1620 lb (735 kg)	None
- Cast Iron (total)	1185 lb (537 kg)	None
Height of Drawbar	20.0 in (510 mm)	20.0 in (510 mm)
Static Weight with operator - Rear	24245 lb (10998 kg)	15980 lb (7249 kg)
- Front	14540 lb (6595 kg)	11255 lb (5105 kg)
- Total	38785 lb (17593 kg)	27235 lb (12354 kg)

DRAWBAR PERFORMANCE
UNBALLASTED - FRONT DRIVE ENGAGED - 1800 RPM
MAXIMUM POWER AT SELECTED SPEED SETTINGS

Power Hp (kW)	Drawbar pull lbs (kN)	Speed mph (km/h)	Crank- shaft speed rpm	Slip %	Fuel Consumption		Temp. °F(°C)		Barom. inch Hg (kPa)
					lb/hp.hr (kg/kW.h)	Hp.hr/gal (kW.h/l)	cool- ing med	Air dry bulb	
3.5 mph (5.6 km/h)									
224.46 (167.38)	27123 (120.65)	3.10 (4.99)	2122	10.3	0.475 (0.289)	14.78 (2.91)	195 (90)	52 (11)	28.92 (97.93)
4.0 mph (6.4 km/h)									
243.38 (181.49)	26135 (116.25)	3.50 (5.62)	2077	9.9	0.456 (0.277)	15.40 (3.03)	204 (95)	60 (16)	28.92 (97.93)
4.3 mph (7.0 km/h)									
255.78 (190.74)	25504 (113.45)	3.76 (6.05)	2034	9.5	0.445 (0.271)	15.77 (3.11)	204 (95)	62 (17)	28.92 (97.93)
4.7 mph (7.6 km/h)									
264.21 (197.02)	24262 (107.92)	4.08 (6.57)	2009	8.1	0.440 (0.267)	15.97 (3.15)	203 (95)	64 (18)	28.92 (97.93)
5.1 mph (8.2 km/h)									
267.86 (199.74)	23628 (105.10)	4.25 (6.84)	1994	7.9	0.435 (0.264)	16.15 (3.18)	203 (95)	66 (19)	28.92 (97.93)
5.6 mph (9.0 km/h)									
276.60 (206.26)	22788 (101.36)	4.55 (7.32)	1878	7.3	0.433 (0.264)	16.20 (3.19)	202 (95)	68 (20)	28.92 (97.93)
6.2 mph (10.0 km/h)									
281.24 (209.72)	21350 (94.97)	4.94 (7.95)	1807	5.6	0.425 (0.259)	16.51 (3.25)	202 (95)	59 (15)	28.94 (98.00)
6.8 mph (11.0 km/h)									
281.46 (209.88)	19327 (85.97)	5.46 (8.79)	1807	5.0	0.425 (0.259)	16.52 (3.25)	202 (95)	60 (16)	28.95 (98.04)
7.5 mph (12.0 km/h)									
281.66 (210.03)	17565 (78.13)	6.02 (9.68)	1806	4.4	0.424 (0.258)	16.57 (3.26)	202 (94)	57 (14)	28.93 (97.97)
8.1 mph (13.0 km/h)									
280.30 (209.02)	16144 (71.81)	6.51 (10.48)	1802	3.9	0.424 (0.258)	16.55 (3.26)	202 (95)	63 (17)	28.96 (98.07)
8.7 mph (14.0 km/h)									
280.30 (209.02)	14903 (66.29)	7.05 (11.35)	1803	3.5	0.425 (0.258)	16.53 (3.26)	202 (94)	63 (17)	28.96 (98.07)
9.3 mph (15.0 km/h)									
279.62 (208.51)	13895 (61.81)	7.55 (12.14)	1800	3.2	0.427 (0.260)	16.46 (3.24)	202 (94)	64 (18)	28.96 (98.07)
9.9 mph (16.0 km/h)									
278.76 (207.87)	12939 (57.56)	8.08 (13.00)	1799	2.9	0.425 (0.259)	16.50 (3.25)	201 (94)	64 (18)	28.96 (98.07)

DRAWBAR PERFORMANCE
UNBALLASTED - FRONT DRIVE ENGAGED - AUTO MODE
MAXIMUM POWER AT SELECTED SPEED SETTINGS

Power Hp (kW)	Drawbar pull lbs (kN)	Speed mph (km/h)	Crank- shaft speed rpm	Slip %	Fuel Consumption		Temp. °F (°C)		Barom. inch Hg (kPa)
					lb/hp.hr (kg/kW.h)	Hp.hr/gal (kW.h/l)	cool- ing med	Air dry bulb	
3.5 mph (5.6 km/h)									
223.78 (166.87)	27025 (120.21)	3.11 (5.00)	1940	12.0	0.470 (0.286)	14.95 (2.95)	204 (96)	54 (12)	28.92 (97.93)
4.0 mph (6.4 km/h)									
241.86 (180.36)	26025 (115.77)	3.49 (5.61)	2081	10.2	0.455 (0.277)	15.42 (3.04)	205 (96)	61 (16)	28.92 (97.93)
4.3 mph (7.0 km/h)									
254.09 (189.47)	25359 (112.80)	3.76 (6.04)	2039	9.8	0.448 (0.272)	15.68 (3.09)	205 (96)	63 (17)	28.92 (97.93)
4.7 mph (7.6 km/h)									
263.48 (196.47)	24229 (107.78)	4.08 (6.57)	2011	8.4	0.439 (0.267)	16.00 (3.15)	205 (96)	65 (18)	28.92 (97.93)
5.1 mph (8.2 km/h)									
269.08 (200.65)	23621 (105.07)	4.27 (6.87)	1994	8.1	0.434 (0.264)	16.17 (3.19)	205 (96)	67 (19)	28.92 (97.93)
5.6 mph (9.0 km/h)									
272.75 (203.39)	22458 (99.90)	4.56 (7.33)	1945	6.7	0.433 (0.264)	16.20 (3.19)	203 (95)	69 (21)	28.92 (97.93)
6.2 mph (10.0 km/h)									
275.93 (205.76)	20761 (92.35)	4.99 (8.02)	1945	5.6	0.429 (0.261)	16.37 (3.23)	203 (95)	59 (15)	28.94 (98.00)
6.8 mph (11.0 km/h)									
275.76 (205.63)	18982 (84.44)	5.45 (8.77)	1945	5.2	0.429 (0.261)	16.37 (3.23)	203 (95)	61 (16)	28.95 (98.04)
7.5 mph (12.0 km/h)									
277.88 (207.21)	17360 (77.22)	6.01 (9.66)	1944	4.4	0.425 (0.259)	16.51 (3.25)	202 (95)	58 (14)	28.94 (98.00)
8.1 mph (13.0 km/h)									
274.55 (204.73)	15792 (70.25)	6.52 (10.49)	1944	3.9	0.430 (0.261)	16.35 (3.22)	203 (95)	63 (17)	28.96 (98.07)
8.7 mph (14.0 km/h)									
274.28 (204.53)	14623 (65.05)	7.04 (11.32)	1945	3.6	0.431 (0.262)	16.31 (3.21)	202 (94)	64 (18)	28.96 (98.07)
9.3 mph (15.0 km/h)									
274.09 (204.39)	13635 (60.65)	7.54 (12.13)	1944	3.3	0.431 (0.262)	16.31 (3.21)	202 (95)	64 (18)	28.96 (98.07)
9.9 mph (16.0 km/h)									
272.74 (203.38)	12656 (56.30)	8.09 (13.01)	1947	3.1	0.434 (0.264)	16.19 (3.19)	201 (94)	65 (18)	28.96 (98.07)

DRAWBAR PERFORMANCE
BALLASTED- FRONT DRIVE ENGAGED - 1800 RPM
MAXIMUM POWER AT SELECTED SPEED SETTINGS

Power Hp (kW)	Drawbar pull lbs (kN)	Speed mph (km/h)	Crank- shaft speed rpm	Slip %	Fuel Consumption lb/hp.hr (kg/kW.h)	Fuel Consumption Hp.hr/gal (kW.h/l)	Temp. °F(°C) cool- ing med	Air dry bulb	Barom. inch Hg (kPa)
211.90 (158.01)	39062 (173.75)	2.03 (3.27)	2113	14.3	0.508 (0.309)	13.82 (2.72)	203 (95)	66 (19)	28.70 (97.19)
248.61 (185.38)	36730 (163.38)	2.54 (4.09)	2010	10.2	0.469 (0.285)	14.98 (2.95)	203 (95)	67 (19)	28.70 (97.19)
263.96 (196.83)	34302 (152.58)	2.89 (4.64)	1924	7.7	0.453 (0.276)	15.49 (3.05)	202 (94)	68 (20)	28.70 (97.19)
271.01 (202.09)	32555 (144.81)	3.13 (5.03)	1804	7.1	0.444 (0.270)	15.83 (3.12)	201 (94)	70 (21)	28.70 (97.19)
274.46 (204.66)	29807 (132.59)	3.45 (5.55)	1802	5.7	0.438 (0.266)	16.05 (3.16)	203 (95)	72 (22)	28.70 (97.19)
276.60 (206.26)	27420 (121.97)	3.78 (6.08)	1802	4.7	0.435 (0.264)	16.15 (3.18)	203 (95)	73 (23)	28.73 (97.29)
279.73 (208.59)	25608 (113.91)	4.10 (6.60)	1802	4.4	0.429 (0.261)	16.37 (3.22)	203 (95)	72 (22)	28.73 (97.29)
281.19 (209.68)	23243 (103.39)	4.54 (7.30)	1807	3.6	0.426 (0.259)	16.46 (3.24)	202 (95)	70 (21)	28.72 (97.26)
281.98 (210.27)	20934 (93.12)	5.06 (8.14)	1804	3.1	0.425 (0.259)	16.51 (3.25)	202 (94)	69 (21)	28.72 (97.26)
281.24 (209.72)	18962 (84.35)	5.56 (8.95)	1801	2.7	0.427 (0.260)	16.45 (3.24)	207 (97)	71 (22)	28.72 (97.26)
278.95 (208.01)	17181 (76.43)	6.09 (9.80)	1805	2.5	0.430 (0.261)	16.35 (3.22)	201 (94)	71 (22)	28.72 (97.26)
276.41 (206.12)	15696 (69.82)	6.61 (10.63)	1801	2.4	0.435 (0.264)	16.15 (3.18)	205 (96)	71 (22)	28.72 (97.26)
274.52 (204.71)	14459 (64.32)	7.12 (11.45)	1801	2.3	0.436 (0.265)	16.09 (3.17)	202 (94)	72 (22)	28.72 (97.26)
274.02 (204.34)	13494 (60.02)	7.62 (12.26)	1798	2.1	0.438 (0.266)	16.05 (3.16)	202 (94)	72 (22)	28.72 (97.26)
273.36 (203.84)	12540 (55.78)	8.18 (13.16)	1804	1.9	0.438 (0.266)	16.03 (3.16)	202 (94)	72 (22)	28.72 (97.26)

HYDRAULIC PERFORMANCE

CATEGORY:	IVN
Quick Attach: Yes	
OECD Static test	
Lift cylinders:	<u>2x112 mm</u>
Maximum force exerted through whole range:	18326 lbs (81.5 kN)
<hr/>	
	<u>85 cc pump</u>
i) Sustained pressure at compensator cutoff:	2899 psi (200 bar) three outlet sets combined
ii) Pump delivery rate at minimum pressure and rated engine speed:	64.3 GPM (243.3 l/min)
iii) Pump delivery rate at maximum hydraulic power:	64.4 GPM (243.6 l/min)
Delivery pressure:	2431 psi (168 bar)
Power:	91.3 HP (68.1 kW)
	single outlet set
<hr/>	
ii) Pump delivery rate at minimum pressure and rated engine speed:	40.3 GPM (152.4 l/min)
iii) Pump delivery rate at maximum hydraulic power:	38.1 GPM (144.3 l/min)
Delivery pressure:	2158 psi (149 bar)
Power:	48.0 HP (35.8 kW)

HITCH DIMENSIONS AS TESTED—NO LOAD

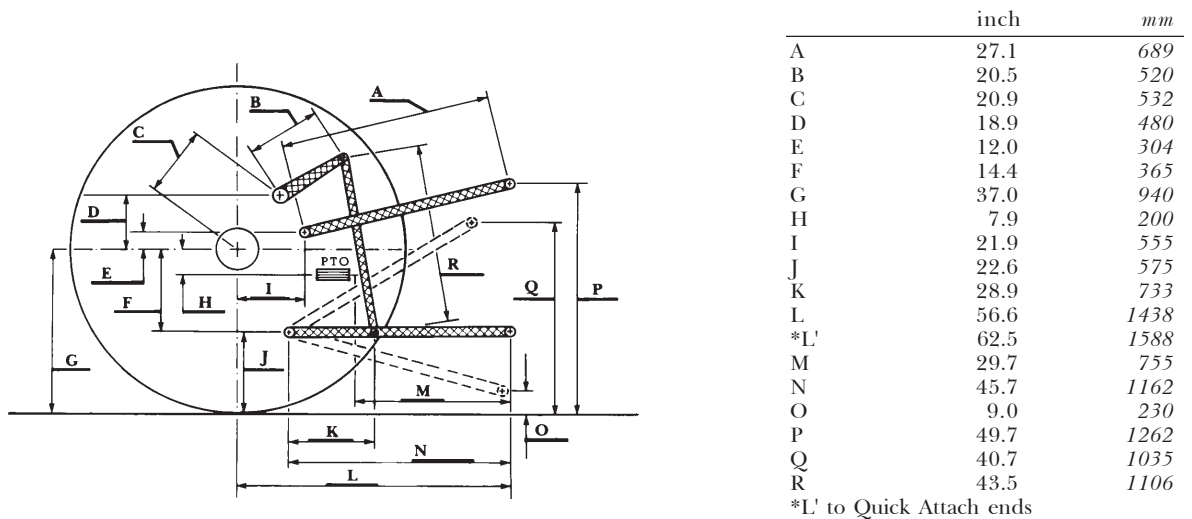

JOHN DEERE 8345R DIESEL