

# SUMMARY OF OECD TEST 2908–NEBRASKA SUMMARY 991A

## MASSEY FERGUSON 8732 DIESEL

### ALSO MASSEY FERGUSON 8732S DIESEL

### DYNA VT TRANSMISSION

#### POWER TAKE-OFF PERFORMANCE

Power HP (kW)	Crank shaft speed rpm	Diesel Consumption		D.E.F. Consumption		Mean Atmospheric Conditions
		Gal/hr (l/h)	lb/hp.hr (kg/kW.h)	Hp.hr/gal (kW.h/l)	Gal/hr (l/h)	
<b>MAXIMUM POWER AND FUEL CONSUMPTION</b>						
<b>Rated Engine Speed—(PTO speed—1065 rpm)</b>						
263.9 (196.8)	2097	15.13 (57.26)	0.399 (0.243)	17.45 (3.44)	0.67 (2.52)	
<b>Standard Power Take-off Speed (999 rpm)</b>						
282.2 (210.4)	1968	15.60 (59.05)	0.386 (0.235)	18.09 (3.56)	0.73 (2.78)	
<b>Maximum Power (1 hour)</b>						
284.8 (212.4)	1954	15.57 (58.95)	0.381 (0.232)	18.29 (3.60)	0.73 (2.78)	
<b>VARYING POWER AND FUEL CONSUMPTION</b>						
263.9 (196.8)	2097	15.13 (57.26)	0.399 (0.243)	17.45 (3.44)	0.67 (2.52)	Air temperature
226.4 (168.8)	2112	13.20 (49.97)	0.407 (0.248)	17.15 (3.38)	0.60 (2.26)	68°F (20°C)
169.9 (126.7)	2115	10.81 (40.93)	0.444 (0.270)	15.71 (3.09)	0.49 (1.87)	Relative humidity
114.0 (85.0)	2123	8.25 (31.22)	0.505 (0.307)	13.81 (2.72)	0.30 (1.13)	34%
57.3 (42.7)	2136	5.23 (19.78)	0.637 (0.388)	10.95 (2.16)	0.16 (0.59)	Barometer
----	2143	2.93 (11.08)	----	----	----	30.4" Hg (102.8 kPa)

Maximum torque - 970 lb.-ft. (1315 Nm) at 1043 rpm  
 Maximum torque rise - 46.8%  
 Torque rise at 1700 engine rpm - 29%  
 Power increase at 1954 engine rpm - 7.9%

#### DRAWBAR PERFORMANCE (Unballasted - Front Drive Engaged) FUEL CONSUMPTION CHARACTERISTICS

Power Hp (kW)	Drawbar pull lbs (kN)	Speed mph (km/h)	Crank- shaft speed rpm	Slip %	Fuel Consumption		Temp. °F (°C)		Barom. inch Hg (kPa)
					lb/hp.hr (kg/kW.h)	Hp.hr/gal (kW.h/l)	cool- ing med	Air dry bulb	
<b>Power at Rated Engine Speed—Rabbit 11</b>									
214.3 (159.8)	12815 (57.0)	6.27 (10.09)	2101	5.5	0.500 (0.304)	13.81 (2.72)	192 (89)	45 (7)	30.1 (101.9)
<b>75% of Pull at Rated Engine Speed—Rabbit 11</b>									
160.8 (119.9)	9555 (42.5)	6.31 (10.16)	2124	2.6	0.542 (0.329)	12.75 (2.51)	190 (88)	45 (7)	30.1 (101.9)
<b>50% of Pull at Rated Engine Speed—Rabbit 11</b>									
111.7 (83.3)	6430 (28.6)	6.51 (10.48)	2131	2.0	0.624 (0.380)	11.07 (2.18)	190 (88)	45 (7)	30.1 (101.9)
<b>75% of Pull at Reduced Engine Speed—Rabbit 14</b>									
160.0 (119.3)	9575 (42.6)	6.26 (10.08)	1641	2.4	0.492 (0.299)	14.06 (2.77)	187 (86)	45 (7)	30.1 (101.9)
<b>50% of Pull at Reduced Engine Speed—Rabbit 14</b>									
112.1 (83.6)	6475 (28.8)	6.49 (10.45)	1646	1.7	0.512 (0.312)	13.48 (2.66)	181 (83)	45 (7)	30.1 (101.9)

**Location of tests:** IRSTE A, Centre d'Antony, 1 rue Pierre-Gilles de Gennes CS 10030 Antony, 92163, Cedex, France

**Dates of tests:** January to April, 2015.

**Manufacturer:** AGCOS.A.S, 41 Avenue Blaise Pascal, 60000 Beauvais, France

**CONSUMABLE FLUIDS:** Fuel No. 2 Diesel Specific gravity converted to 60°/60°F (15°/15°C) 0.837 Fuel weight 6.98 lbs/gal (0.836 kg/l) Diesel Exhaust Fluid (DEF) 32% aqueous urea solution DEF weight 9.08 lbs/gal (1.091 kg/l) Oil SAE 15W40 API service classification CJ-4 Transmission and hydraulic lubricant Terrac Trantan 9 10W/40 Front axle lubricant SAE 85W90 API GL4

**ENGINE:** Make AGCO Power Diesel Type six cylinder vertical with two turbochargers, air to air intercooler and D.E.F. (diesel exhaust fluid) technology Serial No. 84AWF 1020 T06951 Crankshaft lengthwise Rated engine speed 2100 Bore and stroke 4.370" x 5.709" (111.0 mm x 145.0 mm) Compression ratio 16.7 to 1 Displacement 513 cu in (8419 ml) Starting system 12 volt Lubrication pressure Air cleaner two paper elements Oil filter one full flow cartridge Oil cooler engine coolant heat exchanger for crankcase oil, radiator for hydraulic and transmission oil Fuel filter one paper element Muffler vertical Cooling medium temperature control thermostat and variable speed fan

**CHASSIS:** Type front wheel assist Serial No. D035901 Tread width rear 76.0" (1930 mm) to 89.1" (2262 mm) front 61.5" (1560 mm) to 89.4" (2268 mm) Wheelbase 121.8" (3093 mm) Hydraulic control system direct engine drive Transmission CVT. A combination of mechanical and hydrostatic sections allow an infinite speed adjustment within the ranges noted. The transmission has two mechanical ranges. Nominal travel speeds mph (km/h) forward: Low range 0-20 (0-32), high range 0-25 (0-40) reverse: Low range 0-12 (0-20), high range 0-18 (0-30) Clutch a foot pedal controls the hydrostatic oil flow Brakes multiple wet disc hydraulically operated by two foot pedals that can be locked together Steering hydrostatic Power take-off 1000 rpm at 1970 engine rpm Unladen tractor mass 24670 lb (11190 kg)

**DRAWBAR PERFORMANCE**  
**(Unballasted - Front Drive Engaged)**  
**MAXIMUM POWER AT SELECTED TRAVEL SPEEDS**

Power Hp (kW)	Drawbar pull lbs (kN)	Speed mph (km/h)	Crank- shaft speed rpm	Slip %	Fuel lb/hp.hr (kg/kW.h)	Consumption Hp.hr/gal (kW.h/l)	Temp. °F(°C) cool- ing med	Air dry bulb	Barom. inch Hg (kPa)
87.6 (65.3)	22480 (100.0)	1.46 (2.35)	2133	14.2	Turtle 3 0.731 (0.445)	9.44 (1.86)	174 (79)	43 (6)	30.2 (102.1)
146.7 (109.4)	22030 (98.0)	2.50 (4.02)	2100	12.8	Turtle 5 0.602 (0.366)	11.47 (2.26)	178 (81)	43 (6)	30.2 (102.1)
200.9 (149.8)	20275 (90.2)	3.72 (5.98)	2049	7.5	Turtle 6.5 0.521 (0.317)	13.25 (2.61)	178 (81)	43 (6)	30.2 (102.1)
229.4 (171.1)	18410 (81.9)	4.67 (7.52)	1952	5.8	Turtle 8 0.473 (0.288)	14.60 (2.88)	189 (87)	43 (6)	30.1 (102.0)
232.4 (173.3)	14140 (62.9)	6.16 (9.92)	1937	4.8	Turtle 11 0.463 (0.282)	14.91 (2.94)	192 (89)	45 (7)	30.1 (102.0)
232.7 (173.5)	10700 (47.6)	8.15 (13.12)	1945	2.8	Turtle 14 0.458 (0.279)	15.08 (2.97)	187 (86)	45 (7)	30.1 (102.0)
229.4 (171.1)	9260 (41.2)	9.29 (14.95)	1948	2.6	*Turtle 16 0.508 (0.309)	13.60 (2.68)	198 (92)	45 (7)	30.1 (101.8)
229.0 (170.8)	7825 (34.8)	10.98 (17.67)	1944	2.2	*Turtle 18 0.522 (0.318)	13.22 (2.61)	199 (93)	45 (7)	30.1 (101.8)
226.2 (168.7)	17950 (79.8)	4.72 (7.61)	1956	6.3	Rabbit 8.5 0.475 (0.289)	14.55 (2.87)	192 (89)	45 (7)	30.1 (101.8)
231.1 (172.3)	14435 (64.2)	6.00 (9.66)	1959	5.9	Rabbit 11 0.469 (0.286)	14.71 (2.90)	194 (90)	45 (7)	30.1 (101.8)
231.3 (172.5)	10545 (46.9)	8.23 (13.24)	1951	2.8	Rabbit 14 0.471 (0.287)	14.66 (2.89)	187 (86)	45 (7)	30.1 (101.8)
231.7 (172.8)	8815 (39.2)	9.86 (15.87)	1955	2.6	*Rabbit 16 0.511 (0.311)	13.50 (2.66)	203 (95)	46 (8)	30.1 (101.8)
232.5 (173.4)	7845 (34.9)	11.12 (17.89)	1947	2.1	*Rabbit 18 0.510 (0.310)	13.55 (2.67)	198 (92)	46 (8)	30.0 (101.7)
226.9 (169.2)	6700 (29.8)	12.70 (20.44)	1964	1.8	*Rabbit 21 0.525 (0.320)	13.14 (2.59)	194 (90)	48 (9)	30.0 (101.7)

\* Boosted mode

TRACTOR SOUND LEVEL WITH CAB	dB(A)
At no load in Turtle - 4.9mph (7.9 km/h)- no load	71.0
Bystander	---

Horizontal distance of drawbar hitch point behind rear wheel axis - 36.8 in (935 mm), 38.8 in (985 mm), 42.7 in, (1085 mm), 48.6 in (1235 mm)

**TIRES AND WEIGHT**

**Rear Tires** - No., size, ply & psi(kPa)  
**Front Tires** -No., size, ply & psi(kPa)  
**Height of Drawbar**  
**Static Weight with operator** - Rear  
- Front  
- Total

**Tested Without Ballast**

Two 710/75R42;\*\*\*;12(80)  
Two 600/65R34;\*\*\*;19(130)  
21.7 in (550 mm)  
13615 lb (6175 kg)  
11220 lb (5090 kg)  
24835 lb(11265 kg)

**REPAIRS AND ADJUSTMENTS:** No repairs or adjustments.

**NOTE 1:** This tractor has an engine control feature that allows the engine to run in a "boosted" mode, increased power level, at travel speeds above 8.7 mph (14.0 km/h).

**NOTE2:**The performance figures on this report are the result of replacing the electronic engine control module of the Massey Ferguson 8730 with the Massey Ferguson 8732 module.

**REMARKS:** All test results were determined from observed data obtained in accordance with official OECD test procedures. This tractor fell 1.9% short of meeting the manufacturer's claim of 54.2 GPM (205 l/min) remote hydraulic flow. The performance figures on this summary were taken from a test conducted under the OECD Code 2 test procedure.

**REPORT REISSUED:** Supplemental sales permit for Massey Ferguson 8732S Diesel, September, 2018.

We, the undersigned, certify that this is a true summary of data from OECD Report No. **2908**, Nebraska Summary 991A, September 12, 2018.

Roger M. Hoy  
Director

M.F. Kocher  
P.J. Jasa  
J.D. Luck  
Board of Tractor Test Engineers

## HYDRAULIC PERFORMANCE

CATEGORY: III

Quick Attach: Yes

OECD Static test

Maximum force exerted through whole range: 20390 lbs (90.7 kN) (at 24" (610 mm) behind QA ends)  
22460 lbs (99.9 kN) (at QA ends)

i) Sustained pressure at compensator cutoff: 2885 psi (199 bar)  
two outlet sets combined

ii) Pump delivery rate at minimum pressure: 53.1 GPM (201.1 l/min)

iii) Pump delivery rate at maximum

hydraulic power: 47.3 GPM (179.2 l/min)

Delivery pressure: 2435 psi (168 bar)

Power: 67.3 HP (50.2 kW)

single outlet set

ii) Pump delivery rate at minimum pressure: 35.8 GPM (135.5 l/min)

iii) Pump delivery rate at maximum

hydraulic power: 33.8 GPM (127.9 l/min)

Delivery pressure: 2265 psi (156 bar)

Power: 44.6 HP (33.2 kW)

### HITCH DIMENSIONS AS TESTED—NO LOAD

	inch	mm
A	31.9	810
B	14.6	370
C	19.1	484
D	15.9	405
E	8.9	225
F	13.0	330
G	40.4	1025
H	2.4	60
I	18.8	478
J	27.4	695
K	24.7	628
L	49.2	1250
*L'	53.9	1370
M	26.8	680
N	39.9	1014
O	10.2	260
P	50.4	1280
Q	38.5	977
R	37.4	950

\*L' to Quick Attach ends

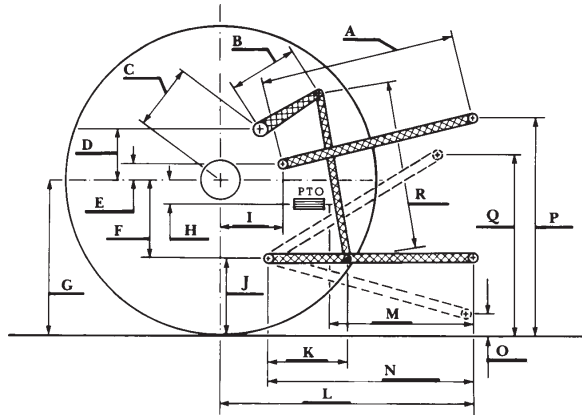

### RECOMMENDED CITATION FORMAT:

NTTL.(2018). OECD tractor test 2908 for Massey Ferguson 8732S Diesel.

Lincoln, NE:Nebraska Tractor Test Laboratory. Retrieved from <http://tractortestlab.unl.edu>