

# SUMMARY OF OECD TEST 2937-NEBRASKA SUMMARY 1028A

## MASSEY FERGUSON 7724 DYNA VT DIESEL

## ALSO MASSEY FERGUSON 7724S DYNA VT DIESEL

### CONTINUOUSLY VARIABLE TRANSMISSION

#### POWER TAKE-OFF PERFORMANCE

Power HP (kW)	Crank shaft speed rpm	Diesel Consumption Gal/hr (l/h)	lb/hp.hr (kg/kW.h)	Hp.hr/gal (kW.h/l)	D.E.F. Consumption Gal/hr (l/h)	Mean Atmospheric Conditions
<b>MAXIMUM POWER AND FUEL CONSUMPTION</b>						
<b>Rated Engine Speed—(PTO speed—1103 rpm)</b>						
201.2 (150.0)	2098	12.24 (46.33)	0.424 (0.258)	16.43 (3.24)	0.75 (2.84)	
<b>Standard Power Take-off Speed (999 rpm)</b>						
221.8 (165.4)	1902	12.45 (47.13)	0.391 (0.238)	17.82 (3.51)	0.83 (3.14)	
<b>Maximum Power (1 hour)</b>						
221.8 (165.4)	1902	12.45 (47.13)	0.391 (0.238)	17.82 (3.51)	0.83 (3.14)	
<b>VARYING POWER AND FUEL CONSUMPTION</b>						
201.2 (150.0)	2098	12.24 (46.33)	0.424 (0.258)	16.43 (3.24)	0.75 (2.84)	Air temperature
172.3 (128.5)	2115	10.63 (40.25)	0.431 (0.262)	16.20 (3.19)	0.64 (2.41)	75°F (24°C)
129.9 (96.9)	2128	8.29 (31.38)	0.445 (0.271)	15.68 (3.09)	0.54 (2.04)	Relative humidity
87.0 (64.9)	2133	6.18 (23.38)	0.495 (0.301)	14.08 (2.77)	0.38 (1.44)	71%
43.7 (32.5)	2140	4.19 (15.85)	0.669 (0.407)	10.42 (2.05)	0.43 (1.62)	Barometer
---	2153	2.37 (8.96)	---	---	---	30.4" Hg (103.1 kPa)

Maximum torque - 755 lb.-ft. (1023 Nm) at 1148 rpm  
 Maximum torque rise - 49.9%  
 Torque rise at 1700 engine rpm - 32%  
 Power increase at 1902 engine rpm - 10%

#### DRAWBAR PERFORMANCE (Unballasted - Front Drive Engaged) FUEL CONSUMPTION CHARACTERISTICS

Power Hp (kW)	Drawbar pull lbs (kN)	Speed mph (km/h)	Crank- shaft speed rpm	Slip %	Fuel Consumption lb/hp.hr (kg/kW.h)	Hp.hr/gal (kW.h/l)	Temp. °F (°C) cool- ing med	Air dry bulb	Barom. inch Hg (kPa)
<b>Power at Rated Engine Speed—Turtle 8</b>									
161.9 (120.7)	12590 (56.0)	4.82 (7.76)	2099	4.6	0.529 (0.322)	13.20 (2.60)	187 (86)	57 (14)	30.4 (102.9)
<b>75% of Pull at Rated Engine Speed—Turtle 8</b>									
124.3 (92.7)	9440 (42.0)	4.95 (7.96)	2123	3.3	0.560 (0.341)	12.46 (2.46)	190 (88)	57 (14)	30.4 (102.9)
<b>50% of Pull at Rated Engine Speed—Turtle 8</b>									
84.6 (63.1)	6360 (28.3)	4.99 (8.03)	2131	2.2	0.620 (0.377)	11.26 (2.22)	194 (90)	57 (14)	30.4 (102.9)
<b>75% of Pull at Reduced Engine Speed—Turtle 10</b>									
125.0 (93.2)	9465 (42.1)	4.95 (7.97)	1366	3.0	0.461 (0.281)	15.13 (2.98)	199 (93)	55 (13)	30.4 (102.8)
<b>50% of Pull at Reduced Engine Speed—Turtle 10</b>									
85.3 (63.6)	6340 (28.2)	5.05 (8.12)	1370	2.3	0.507 (0.309)	13.76 (2.71)	196 (91)	55 (13)	30.4 (102.8)

**Location of tests:** IRSTEA, Centre d'Antony, 1 rue Pierre-Giles de Gennes, CS 10030 92761 Antony, Cedex France

**Dates of tests:** November, 2015 to January, 2016

**Manufacturer:** AGCO S.A. ZA, n2, BP 60307, Avenue Blaise Pascal, 60026 Beauvais, Cedex, France

**CONSUMABLE FLUIDS:** Fuel No. 2 Diesel Specific gravity converted to 60°/60°F (15°/15°C) 0.838 Fuel weight 6.98 lbs/gal (0.836 kg/l) Diesel Exhaust Fluid (DEF) 32% aqueous urea solution DEF weight 9.08 lbs/gal (1.091 kg/l) Oil SAE 15W40 API service classification CJ-4 Transmission and hydraulic lubricant BP Terrac Tractan 9 10W/40 Front axle lubricant SAE 85W140 API GL-5

**ENGINE:** Make AGCO Power Diesel Type six cylinder vertical with turbocharger, air to air intercooler and SCR (selective catalyst reduction) technology Serial No. Z0016 Crankshaft lengthwise Rated engine speed 2100 Bore and stroke 4.252" x 5.276" (108.0 mm x 134.0 mm) Compression ratio 17.8 to 1 Displacement 449 cu in (7365 ml) Starting system 12 volt Lubrication pressure Air cleaner two paper elements Oil filter one full flow cartridge Oil cooler engine coolant heat exchanger for crankcase oil, radiator for hydraulic and transmission oil Fuel filter one paper element Muffler underhood Exhaust vertical Cooling medium temperature control thermostat and variable speed fan

**CHASSIS:** Type front wheel assist Serial No. D192901 Tread width rear 52.8" (1340 mm) to 87.8" (2230 mm) front 52.8" (1340 mm) to 87.8" (2230 mm) Wheelbase 117.0" (2973 mm) Hydraulic control system direct engine drive Transmission CVT. A combination of mechanical and hydrostatic sections allow an infinite speed adjustment within the ranges noted. The transmission has two mechanical ranges. Nominal travel speeds mph (km/h) forward: Low range 0-19 (0-30), high range 0-25 (0-40) reverse: Low range 0-19 (0-30), high range 0-19 (0-30) Clutch a foot pedal controls the hydrostatic oil flow Brakes multiple wet disc hydraulically operated by two foot pedals that can be locked together Steering hydrostatic Power take-off 540 rpm at 1868 engine rpm or 1000 rpm at 1903 engine rpm Unladen tractor mass 18465 lb (8375 kg)

## DRAWBAR PERFORMANCE

(Unballasted - Front Drive Engaged)

### MAXIMUM POWER AT SELECTED TRAVEL SPEEDS

Power Hp (kW)	Drawbar pull lbs (kN)	Speed mph (km/h)	Crank- shaft speed rpm	Slip %	Fuel Consumption lb/hp.hr (kg/kW.h)	Consumption Hp.hr/gal (kW.h/l)	Temp. <sup>o</sup> F(°C) cool- ing med	Air dry bulb	Barom. inch Hg (kPa)
Turtle 3									
70.4 (52.5)	16480 (73.3)	1.60 (2.58)	2135	14.3	0.681 (0.414)	10.25 (2.02)	178 (81)	57 (14)	30.4 (102.9)
Turtle 4.5									
107.8 (80.4)	16345 (72.7)	2.47 (3.98)	2124	12.8	0.637 (0.388)	10.95 (2.16)	185 (85)	57 (14)	30.4 (102.9)
Turtle 6.5									
142.9 (106.6)	15915 (70.8)	3.37 (5.42)	2104	11.0	0.595 (0.362)	11.73 (2.31)	185 (85)	57 (14)	30.4 (102.9)
Turtle 8									
168.0 (125.3)	14185 (63.1)	4.44 (7.15)	2056	6.5	0.511 (0.311)	13.65 (2.69)	185 (85)	57 (14)	30.4 (102.9)
Turtle 10									
173.8 (129.6)	11130 (49.5)	5.87 (9.44)	1892	4.2	0.502 (0.306)	13.90 (2.74)	189 (87)	55 (13)	30.4 (102.9)
Turtle 13									
175.7 (131.0)	9260 (41.2)	7.11 (11.44)	1921	2.8	0.502 (0.306)	13.90 (2.74)	191 (88)	55 (13)	30.4 (102.9)
Turtle 15									
167.0 (124.5)	7195 (32.0)	8.71 (14.01)	1908	2.6	0.525 (0.320)	13.28 (2.62)	191 (88)	55 (13)	30.4 (102.9)
Rabbit 9									
145.1 (108.2)	11445 (50.9)	4.75 (7.65)	1920	5.2	0.590 (0.359)	11.83 (2.33)	181 (83)	55 (13)	30.4 (102.9)
Rabbit 12									
173.0 (129.0)	9195 (40.9)	7.05 (11.35)	1898	3.4	0.510 (0.310)	13.70 (2.70)	187 (86)	55 (13)	30.4 (102.9)
Rabbit 15									
174.6 (130.2)	7575 (33.7)	8.64 (13.90)	1926	2.8	0.492 (0.300)	14.22 (2.80)	189 (87)	55 (13)	30.4 (102.9)
Rabbit 17									
168.4 (125.6)	6450 (28.7)	9.80 (15.77)	1951	2.6	0.513 (0.312)	13.60 (2.68)	190 (88)	55 (13)	30.4 (102.9)
Rabbit 20									
156.8 (116.9)	5330 (23.7)	11.04 (17.76)	1945	1.6	0.556 (0.338)	12.54 (2.47)	183 (84)	55 (13)	30.4 (102.9)

**REPAIRS AND ADJUSTMENTS:** No repairs or adjustments.

**NOTE:** The performance figures on this report are the result of replacing the electronic engine control module of the Massey Ferguson 7726 Dyna VT with the Massey Ferguson 7724 Dyna VT module.

**REMARKS:** All test results were determined from observed data obtained in accordance with official OECD test procedures. This tractor fell 9.5% short of meeting the manufacturer's 3 point lift claim of 16700 lbs (7575 kg). The performance figures on this summary were taken from a test conducted under the OECD Code 2 test procedure.

**REPORT REISSUED:** Supplemental sales permit for Massey Ferguson 7724S Dyna VT Diesel, August, 2018.

We, the undersigned, certify that this is a true summary of data from OECD Report No. **2937**, Nebraska Summary 1028A, December 18, 2018.

Roger M. Hoy  
Director

M.F. Kocher  
J.D. Luck  
P.J. Jasa  
Board of Tractor Test Engineers

TRACTOR SOUND LEVEL WITH CAB	Front wheel drive	
	Engaged dB(A)	Disengaged dB(A)
At no load in Turtle 8	70.0	70.0
Bystander		--

Horizontal distance of drawbar hitch point behind rear wheel axis - 33.6 in (854 mm), 37.6 in (954 mm), 39.5 in (1004 mm), 43.5 in (1104 mm), 45.4 in (1154 mm), 49.4 in (1254 mm)

#### TIRES, BALLAST AND WEIGHT

**Rear Tires** - No., size, ply & psi (kPa)  
**Front Tires** - No., size, ply & psi (kPa)  
**Height of Drawbar**  
**Static Weight with operator** - Rear  
 - Front  
 - Total

#### Tested without ballast

Two 620/70R42; \*\*; 13(90)  
 Two 480/70R30; \*\*; 16(110)  
 19.3 in (490 mm)  
 10980 lb (4980 kg)  
 7650 lb (3470 kg)  
 18630 lb (8450 kg)

## HYDRAULIC PERFORMANCE

CATEGORY: III

Quick Attach: None

OECD Static test

Maximum force exerted through whole range: 15105 lbs (67.2 kN)

i) Sustained pressure of the open relief valve: 2870 psi (198 bar)

Standard pump

29 GPM (110 l/min)

Optional pump

50 GPM (190 l/min)

two outlet sets combined

29.9 GPM (113.0 l/min)

two outlet sets combined

52.5 GPM (198.8 l/min)

ii) Pump delivery rate at minimum pressure:

iii) Pump delivery rate at maximum

hydraulic power:

Delivery pressure:

Power:

27.8 GPM (105.3 l/min)

2490 psi (172 bar)

40.3 HP (30.0 kW)

47.6 GPM (180.2 l/min)

1855 psi (128 bar)

51.5 HP (38.4 kW)

single outlet set

29.4 GPM (111.2 l/min)

single outlet set

32.9 GPM (124.6 l/min)

ii) Pump delivery rate at minimum pressure:

iii) Pump delivery rate at maximum

hydraulic power:

Delivery pressure:

Power:

26.9 GPM (101.9 l/min)

2235 psi (154 bar)

35.1 HP (26.2 kW)

30.0 GPM (113.8 l/min)

2110 psi (146 bar)

37.0 HP (27.6 kW)

### HITCH DIMENSIONS AS TESTED—NO LOAD

	inch	mm
A	29.8	756
B	15.7	400
C	16.5	419
D	14.0	355
E	8.8	223
F	10.9	276
G	36.4	925
H	2.4	60
I	18.5	471
J	25.5	649
K	27.4	696
L	46.9	1192
M	23.6	600
N	39.5	1003
O	9.0	229
P	52.5	1334
Q	40.2	1020
R	33.1	840

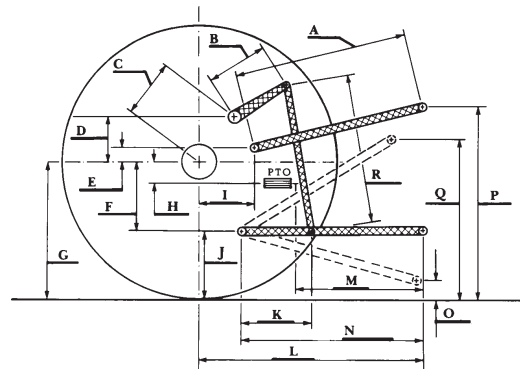

### RECOMMENDED CITATION FORMAT:

NTTL.(2018). OECD tractor test 2937 for Massey Ferguson 7724S Dyna VT Diesel.  
Lincoln, NE:Nebraska Tractor Test Laboratory. Retrieved from <http://tractortestlab.unl.edu>