

NEBRASKA OECD TRACTOR TEST 2224-SUMMARY 1171

JOHN DEERE 8R 410 DIESEL

e23 TRANSMISSION

POWER TAKE-OFF PERFORMANCE

Power HP (kW)	Crank shaft speed rpm	Diesel Consumption		D.E.F. Consumption		Mean Atmospheric Conditions
		Gal/hr (l/h)	lb/hp.hr (kg/kW.h)	Hp.hr/gal (kW.l/l)	Gal/hr (l/h)	
MAXIMUM POWER AND FUEL CONSUMPTION						
Rated Engine Speed—(PTO speed—1052 rpm)						
339.73 (253.34)	2099	17.29 (65.45)	0.355 (0.216)	19.65 (3.87)	0.54 (2.03)	Fuel used during active exhaust regeneration-0.87 gal (3.28l) (see note 1, p.2)
Standard Power Take-off Speed(1000 rpm)						
369.06 (275.20)	1995	18.51 (70.05)	0.350 (0.213)	19.94 (3.93)	0.58 (2.19)	
Maximum Power (1 hour)						
384.10 (286.43)	1800	18.95 (71.73)	0.344 (0.210)	20.27 (3.99)	0.58 (2.19)	

VARYING POWER AND FUEL CONSUMPTION

339.73 (253.34)	2099	17.29 (65.45)	0.355 (0.216)	19.65 (3.87)	0.54 (2.03)	Air temperature
296.68 (221.23)	2154	15.46 (58.51)	0.364 (0.221)	19.20 (3.78)	0.48 (1.82)	72°F (22°C)
223.38 (166.57)	2167	12.16 (46.01)	0.380 (0.231)	18.38 (3.62)	0.38 (1.43)	Relative humidity
149.86 (111.75)	2177	8.98 (34.01)	0.419 (0.255)	16.68 (3.29)	0.30 (1.15)	21%
75.20 (56.07)	2188	6.22 (23.53)	0.577 (0.351)	12.10 (2.38)	0.14 (0.52)	Barometer
1.65 (1.23)	2199	4.30 (16.29)	18.253 (11.103)	0.38 (0.08)	0.08 (0.32)	28.99" Hg (98.17kPa)

Maximum Torque - 1234 lb.-ft. (1673 Nm) at 1550 rpm

Maximum Torque Rise - 45.2%

Torque rise at 1680 engine rpm - 40%

Power increase at 1800 engine rpm - 13.1%

DRAWBAR PERFORMANCE

UNBALLASTED - FRONT DRIVE ENGAGED FUEL CONSUMPTION CHARACTERISTICS

Power Hp (kW)	Drawbar pull lbs (kN)	Speed mph (km/h)	Crank- shaft speed rpm	Slip %	Fuel Consumption lb/hp.hr (kg/kW.h)	D.E.F. Consumption lb/hp.hr (kg/kW.h)	Temp. °F(°C) cool- ing dry med bulb	Barom. inch Hg (kPa)
Power at Rated Engine Speed—10th Gear-Manual mode								
330.42 (246.39)	23336 (103.80)	5.31 (8.55)	2100	4.6	0.404 (0.246)	17.28 (3.40)	0.015 (0.009)	216 (102)
75% of Pull at Rated Engine Speed—10th Gear-Manual mode								
258.49 (192.76)	17495 (77.82)	5.54 (8.92)	2160	3.2	0.410 (0.249)	17.02 (3.35)	0.015 (0.009)	212 (100)
50% of Pull at Rated Engine Speed—10th Gear-Manual mode								
175.00 (130.49)	11656 (51.85)	5.63 (9.06)	2174	2.2	0.439 (0.267)	15.90 (3.13)	0.016 (0.010)	210 (99)
75% of Pull at Reduced Engine Speed—5.8 mph (9.4 km/h) Auto mode								
258.68 (192.89)	17380 (77.31)	5.58 (8.98)	1395	3.2	0.376 (0.229)	18.56 (3.66)	0.017 (0.010)	210 (99)
50% of Pull at Reduced Engine Speed—5.8 mph (9.4 km/h) Auto mode								
174.54 (130.15)	11612 (51.65)	5.64 (9.08)	1214	2.2	0.386 (0.235)	18.11 (3.57)	0.015 (0.009)	207 (97)

Location of tests: Nebraska Tractor Test Laboratory,
University of Nebraska, Lincoln, Nebraska 68583-0832

Dates of tests: October 14 - 22, 2020

Manufacturer: John Deere Tractor Works, 3500
East Donald St., P.O. Box 270, Waterloo Ia,
50704-0270

CONSUMABLE Fluids, OIL and TIME: Fuel No. 2 Diesel **Specific gravity converted to 60°/60°F (15°/15°C)** 0.8386 **Fuel weight** 6.982 lbs/gal (0.837 kg/l) **Diesel Exhaust Fluid (DEF)** 32% aqueous urea solution **DEF weight** 9.071 lbs/gal (1.087 kg/l) **Oil SAE 10W-30 API service classification CK-4 Transmission and hydraulic lubricant** John Deere Hy-Gard fluid **Front axle lubricant** John Deere Hy-Gard fluid **Total time engine was operated:** 24.0 hours

ENGINE: Make John Deere **Diesel Type** six cylinder vertical with two turbochargers, air to air aftercooler and D.E.F (diesel exhaust fluid) exhaust treatment **Serial No.** *RG6090U086967* **Crankshaft** lengthwise **Rated engine speed** 2100 **Bore and stroke** 4.661" x 5.354" (118.4 mm x 136.0 mm) **Compression ratio** 16.0 to 1 **Displacement** 548 cu in (8984 ml) **Starting system** 12 volt **Lubrication** pressure **Air cleaner** two paper elements and aspirator **Oil filter** one full flow cartridge **Oil cooler** engine coolant heat exchanger for crankcase oil, radiator for hydraulic and transmission oil **Fuel filter** one paper element and water separator **Fuel cooler** radiator for pump return fuel **Exhaust DOC** (diesel oxidation catalyst), SCR (selective catalyst reduction) and regenerative DPF (diesel particulate filter) integrated within a vertical muffler **Cooling medium temperature control** thermostat and variable speed fan

ENGINE OPERATING PARAMETERS: Fuel rate: Stationary PTO operations (370 engine hp) 117.1 - 126.5 lb/h (53.1 - 57.4 kg/h) Drawbar operations (410 engine hp) 129.8 - 140.7 lb/h (58.9 - 63.8 kg/h) **High idle:** 2190 - 2210 rpm **Turbo boost:** nominal 30.4 - 34.8 psi (210 - 240 kPa) as measured 31.0 psi (215 kPa)

CHASSIS: Type front wheel assist with duals **Serial No.** *1RW8410DELB170206* **Tread width** rear 60.0" (1524 mm) to 188.6" (4790 mm) front 60.0" (1524 mm) to 144.0" (3657 mm) **Wheelbase** 120.1" (3050 mm) **Hydraulic control system** direct engine drive **Transmission** selective gear fixed ratio with full range power shift **Nominal travel speeds mph (km/h)** first 1.49 (2.40) second 1.73 (2.78) third 2.00 (3.22) fourth 2.32 (3.74) fifth 2.69 (4.33) sixth 3.12 (5.03) seventh 3.59 (5.77) eighth 4.16 (6.70) ninth 4.82 (7.75) tenth 5.58 (8.98) eleventh 6.47 (10.42) twelfth 7.49 (12.06)

DRAWBAR PERFORMANCE
UNBALLASTED - FRONT DRIVE ENGAGED
MANUAL MODE - 2100 ENGINE RPM
DRAWBAR POWER AT SELECTED TRAVEL SPEED SETTINGS

Power Hp (kW)	Drawbar pull lbs (kN)	Speed mph (km/h)	Crank-shaft speed rpm	Slip %	Fuel Consumption lb/hp.hr (kg/kW.h)	D.E.F. Consumption lb/hp.hr (kg/kW.h)	Temp. °F(°C) cooling med	Air dry bulb	Barom. inch Hg (kPa)	
					8th Gear					
299.56 (223.38)	30452 (135.46)	3.69 (5.94)	2145	12.7	0.433 (0.263)	16.14 (3.18)	0.015 (0.009)	214 (101)	43 (6)	28.92 (97.93)
					9th Gear					
324.56 (242.02)	27112 (120.60)	4.49 (7.23)	2100	6.5	0.412 (0.251)	16.94 (3.34)	0.014 (0.009)	215 (102)	63 (17)	28.46 (96.36)
					10th Gear					
330.42 (246.39)	23336 (103.80)	5.31 (8.55)	2100	4.6	0.404 (0.246)	17.28 (3.40)	0.015 (0.009)	216 (102)	61 (16)	28.45 (96.33)
					11th Gear					
332.91 (248.25)	20035 (89.12)	6.23 (10.03)	2099	3.5	0.398 (0.242)	17.53 (3.45)	0.015 (0.009)	216 (102)	61 (16)	28.44 (96.29)
					12th Gear					
332.55 (247.98)	17231 (76.65)	7.24 (11.65)	2100	3.1	0.401 (0.244)	17.40 (3.43)	0.015 (0.009)	216 (102)	65 (18)	28.47 (96.41)
					13th Gear					
332.03 (247.59)	14742 (65.57)	8.45 (13.60)	2099	2.5	0.402 (0.244)	17.38 (3.42)	0.014 (0.009)	216 (102)	67 (19)	28.47 (96.41)

thirteenth 8.70 (14.00) fourteenth 9.99 (16.08)
 fifteenth 11.60 (18.67) sixteenth 13.22 (21.27)
 seventeenth 15.35 (24.70) eighteenth 17.78 (28.61)
 nineteenth 20.64 (33.22) twentieth 23.89 (38.44)
 twenty-first 26.10 (42.00) twenty-second 26.10
 (42.00) twenty-third 26.10 (42.00) electronically
 limited reverse 1.79 (2.88), 2.41 (3.88), 3.24 (5.21),
 4.32 (6.95), 4.99 (8.03), 6.71 (10.80), 9.02 (14.51),
 12.02 (19.35), 15.91 (25.60) 18.64 (30.00), 18.64
 (30.00) electronically limited **Clutch** wet multiple
 disc hydraulically actuated by foot pedal **Brakes**
 wet multiple disc hydraulically operated by two
 foot pedals that can be locked together **Steering**
 hydrostatic **Power take-off** 1000 rpm at 1995
 engine rpm **Unladen tractor mass** 30050 lb (13630
 kg)

REPAIRS AND ADJUSTMENTS: No repairs or adjustments.

NOTE 1: The manufacturer declares that the average time between active regenerations is 40 hours. A 2% power decrease was observed during the active regeneration.

NOTE 2. In stationary PTO operation, this model operates in a derated power mode.

REMARKS: All test results were determined from observed data obtained in accordance with official OECD, SAE and Nebraska test procedures. The performance figures on this summary were taken from a test conducted under the OECD Code 2 test procedure.

We, the undersigned, certify that this is a true and correct report of official Tractor Test No. **2224**, Nebraska Summary 1171, March 3, 2021.

Roger M. Hoy
 Director

M.F. Kocher
 P.J. Jasa
 J.D. Luck
 Board of Tractor Test Engineers

TRACTOR SOUND LEVEL WITH CAB	Front Wheel Drive	
	Engaged dB(A)	Disengaged dB(A)
At no load in 9th gear	66.4	66.4
Transport speed- no load - 20th gear		69.5
Bystander in 20th gear		84.0

Horizontal distance of drawbar hitch point behind rear wheel axis - 48.7"(1237 mm)

TIRES, BALLAST AND WEIGHT	With Ballast	Without Ballast
Rear Tires - No., size, ply & psi(kPa)	Six 480/80R50;***;11(75)	Four 480/80R50;***;11(75)
Ballast - Triples (total)	2020 lb (916 kg)	None
- Cast Iron (total)	5565 lb (2524 kg)	None
Front Tires - No., size, ply & psi(kPa)	Four 420/85R34;***;19(130)	Four 420/85R34;***;14(95)
Ballast - Cast Iron(total)	2465 lb (1118 kg)	None
- Liquid (total)	None	None
Height of Drawbar	21.0 in (535 mm)	21.0 in (535 mm)
Static Weight with operator - Rear	22900 lb(10387 kg)	16765 lb (7605 kg)
- Front	17375 lb (7881 kg)	13460 lb (6105 kg)
- Total	40275 lb(18268 kg)	30225 lb(13710 kg)

DRAWBAR PERFORMANCE
UNBALLASTED - FRONT DRIVE ENGAGED - AUTO MODE
(Loads based on 2100 engine rpm manual mode performance runs)

Power Hp (kW)	Drawbar pull lbs (kN)	Speed mph (km/h)	Crank- shaft speed rpm	Slip %	Fuel Consumption lb/hp.hr (kg/kW.h)	Hp.hr/gal (kW.h/l)	D.E.F. Consumption lb/hp.hr (kg/kW.h)	Temp. °F(°C) cool- ing med	Air dry bulb	Barom. inch Hg (kPa)
4.8 mph (7.8 km/h)										
323.03 (240.88)	27183 (120.91)	4.46 (7.18)	1804	6.8	0.407 (0.247)	17.17 (3.38)	0.015 (0.009)	216 (102)	64 (18)	28.47 (96.39)
5.6 mph (9.0 km/hr)										
330.03 (246.10)	23525 (104.64)	5.26 (8.47)	1795	4.8	0.394 (0.240)	17.72 (3.49)	0.015 (0.009)	215 (102)	62 (17)	28.45 (96.34)
6.6 mph (10.6 km/h)										
332.54 (247.97)	19885 (88.45)	6.27 (10.09)	1826	3.5	0.384 (0.233)	18.20 (3.59)	0.014 (0.008)	213 (101)	61 (16)	28.44 (96.31)
7.6 mph (12.2 km/h)										
332.92 (248.26)	17226 (76.62)	7.25 (11.67)	1811	3.1	0.389 (0.236)	17.97 (3.54)	0.014 (0.009)	215 (101)	65 (18)	28.47 (96.41)
8.8 mph (14.2 km/h)										
331.39 (247.11)	14657 (65.20)	8.48 (13.65)	1834	2.5	0.390 (0.237)	17.89 (3.52)	0.014 (0.008)	214 (101)	68 (20)	28.48 (96.44)

**DRAWBAR PERFORMANCE
UNBALLASTED - FRONT DRIVE ENGAGED
MANUAL MODE - 1850 ENGINE RPM**

Power Hp (kW)	Drawbar pull lbs (kN)	Speed mph (km/h)	Crank- shaft speed rpm	Slip %	Fuel Consumption lb/hp.hr (kg/kW.h)	Hp.hr/gal (kW.h/l)	D.E.F. Consumption lb/hp.hr (kg/kW.h)	Temp. °F(°C) cool- ing med	Air dry bulb	Barom. inch Hg (kPa)
8th Gear										
299.16 (223.08)	30414 (135.29)	3.69 (5.94)	2142	12.6	0.435 (0.264)	16.07 (3.17)	0.015 (0.009)	215 (101)	43 (6)	28.92 (97.93)
9th Gear										
333.91 (249.00)	28627 (127.34)	4.38 (7.04)	2073	7.7	0.407 (0.247)	17.17 (3.38)	0.014 (0.009)	214 (101)	42 (6)	28.94 (98.00)
10th Gear										
352.76 (263.05)	26960 (119.92)	4.91 (7.90)	1980	6.5	0.405 (0.246)	17.24 (3.40)	0.011 (0.007)	216 (102)	42 (6)	28.95 (98.04)
11th Gear										
364.59 (271.87)	25473 (113.31)	5.37 (8.64)	1850	5.7	0.396 (0.241)	17.62 (3.47)	0.011 (0.007)	214 (101)	42 (6)	28.95 (98.04)
12th Gear										
368.13 (274.51)	21917 (97.49)	6.30 (10.14)	1851	4.4	0.392 (0.239)	17.80 (3.51)	0.011 (0.007)	216 (102)	43 (6)	28.95 (98.04)
13th Gear										
368.92 (275.10)	18756 (83.43)	7.38 (11.87)	1851	3.5	0.392 (0.238)	17.82 (3.51)	0.011 (0.007)	216 (102)	44 (7)	28.96 (98.07)
14th Gear										
370.45 (276.24)	16322 (72.60)	8.51 (13.70)	1850	3.0	0.391 (0.238)	17.84 (3.52)	0.011 (0.007)	214 (101)	44 (7)	28.97 (98.10)

Lugging ability in 12th gear

Crankshaft speed rpm	2100	2000	1950	1850	1700	1500	1300	1106
Pull-lbs (kN)	17174 (76.39)	19364 (86.14)	20052 (89.19)	21440 (95.37)	22889 (101.81)	23654 (105.22)	22005 (97.88)	20068 (89.27)
Increase in pull %	0	13	17	25	33	38	28	17
Power-Hp (kW)	331.60 (247.27)	354.12 (264.06)	356.72 (266.01)	360.13 (268.55)	351.36 (262.01)	319.03 (237.90)	258.77 (192.96)	202.13 (150.73)
Speed-mpH (km/h)	7.24 (11.65)	6.86 (11.04)	6.67 (10.73)	6.30 (10.14)	5.76 (9.26)	5.06 (8.14)	4.41 (7.10)	3.78 (6.08)
Slip %		3.0	3.6	3.8	4.3	4.9	5.3	4.7

**DRAWBAR PERFORMANCE
BALLASTED - FRONT DRIVE ENGAGED
MANUAL MODE - 1850 ENGINE RPM**

Power Hp (kW)	Drawbar pull lbs (kN)	Speed mph (km/h)	Crank- shaft speed rpm	Slip %	Fuel Consumption lb/hp.hr (kg/kW.h)	Hp.hr/gal (kW.h/l)	D.E.F. Consumption lb/hp.hr (kg/kW.h)	Temp. °F(°C) cool- ing med	Air dry bulb	Barom. inch Hg (kPa)
6th Gear										
297.10 (221.54)	40419 (179.79)	2.76 (4.44)	2141	13.0	0.442 (0.269)	15.78 (3.11)	0.014 (0.009)	213 (100)	45 (7)	28.90 (97.87)
7th Gear										
328.27 (244.79)	38478 (171.16)	3.20 (5.15)	2059	8.6	0.419 (0.255)	16.68 (3.29)	0.014 (0.008)	214 (101)	45 (7)	28.90 (97.85)
8th Gear										
351.67 (262.24)	36755 (163.49)	3.59 (5.78)	1957	7.0	0.409 (0.249)	17.06 (3.36)	0.010 (0.006)	214 (101)	46 (8)	28.90 (97.87)
9th Gear										
360.21 (268.61)	33893 (150.76)	3.99 (6.41)	1850	5.6	0.402 (0.244)	17.37 (3.42)	0.011 (0.006)	215 (102)	47 (8)	28.90 (97.87)
10th Gear										
365.72 (272.72)	29289 (130.28)	4.68 (7.53)	1850	4.2	0.397 (0.242)	17.58 (3.46)	0.010 (0.006)	214 (101)	47 (8)	28.90 (97.87)
11th Gear										
365.63 (272.65)	24971 (111.08)	5.49 (8.84)	1849	3.2	0.395 (0.240)	17.66 (3.48)	0.012 (0.007)	215 (102)	48 (9)	28.89 (97.83)
12th Gear										
369.70 (275.68)	21706 (96.55)	6.39 (10.28)	1850	2.7	0.392 (0.239)	17.81 (3.51)	0.011 (0.007)	214 (101)	48 (9)	28.89 (97.83)
13th Gear										
366.08 (272.99)	18421 (81.94)	7.45 (11.99)	1849	2.2	0.395 (0.240)	17.67 (3.48)	0.011 (0.006)	216 (102)	48 (9)	28.89 (97.83)
14th Gear										
365.85 (272.81)	15982 (71.09)	8.59 (13.82)	1851	2.0	0.395 (0.240)	17.67 (3.48)	0.011 (0.007)	215 (101)	49 (9)	28.89 (97.83)

HYDRAULIC PERFORMANCE

CATEGORY: IVN
Quick Attach: Yes
OECD Static test

	Lift cylinders	
Maximum force exerted through whole range:	20254 lbs (90.1 kN) 2x115 mm	15229 lbs (67.7 kN) 2x100 mm
	85 cc pump	85 cc and 35cc pumps combined
i) Sustained pressure at compensator cutoff:	2933 psi (200 bar)	2941 psi (203 bar)
	three outlet sets combined	
ii) Pump delivery rate at minimum pressure and rated engine speed:	60.5 GPM(229.0 l/min)	84.2 GPM(318.7 l/min)
iii) Pump delivery rate at maximum hydraulic power:	59.9 GPM(226.9 l/min)	80.0 GPM(302.9 l/min)
Delivery pressure:	2556 psi (176 bar)	2114 psi (146 bar)
Power:	89.4 HP (59.4 kW)	98.7 HP (73.6 kW)
	single outlet set	
ii) Pump delivery rate at minimum pressure and rated engine speed:	1/2" couplers 36.5 GPM(138.0 l/min)	3/4" couplers 42.9 GPM(162.5 l/min)
iii) Pump delivery rate at maximum hydraulic power:	33.8 GPM(127.9 l/min)	41.5 GPM(157.2 l/min)
Delivery pressure:	2430 psi (168 bar)	2301 psi (159 bar)
Power:	47.9 HP (35.7 kW)	55.8 HP (41.6 kW)

HITCH DIMENSIONS AS TESTED—NO LOAD

	inch	mm
A	28.5	725
B	20.5	520
C	20.9	532
D	18.9	480
E	12.0	304
F	14.4	365
G	38.2	970
H	9.1	230
I	23.6	599
J	23.8	605
K	28.7	730
L	52.8	1340
*L'	58.7	1490
M	25.9	657
N	40.1	1019
O	9.1	230
P	50.1	1272
Q	41.5	1055
R	45.7	1160

*L' to Quick Attach ends

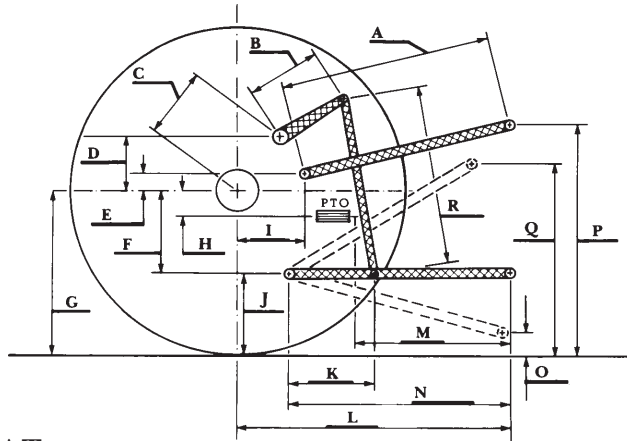

RECOMMENDED CITATION FORMAT:

NTTL.(2021). Nebraska OECD tractor test 2224 for John Deere 8R 410 e23 Diesel.
Lincoln, NE:Nebraska Tractor Test Laboratory. Retrieved from <http://tractortestlab.unl.edu>



JOHN DEERE 8R 410 DIESEL