

NEBRASKA OECD TRACTOR TEST 2131-SUMMARY 1001

JOHN DEERE 8370R DIESEL

e23 TRANSMISSION

POWER TAKE-OFF PERFORMANCE

Power HP (kW)	Crank shaft speed rpm	Diesel Consumption		D.E.F. Consumption		Mean Atmospheric Conditions
		Gal/hr (l/h)	lb/hp.hr (kg/kW.h)	Hp.hr/gal (kW.h/l)	Gal/hr (l/h)	
MAXIMUM POWER AND FUEL CONSUMPTION						
Rated Engine Speed—(PTO speed—1052 rpm)						
333.56 (248.73)	2099	17.62 (66.68)	0.370 (0.225)	18.93 (3.73)	0.34 (1.29)	Fuel used during active exhaust regeneration-0.95 gal (3.60 l) (see note 1, p.2)
Standard Power Take-off Speed(1000 rpm)						
361.83 (269.82)	1995	18.95 (71.75)	0.367 (0.223)	19.09 (3.76)	0.31 (1.16)	
Maximum Power (1 hour)						
375.33 (279.88)	1849	19.51 (73.86)	0.364 (0.221)	19.24 (3.79)	0.31 (1.17)	

VARYING POWER AND FUEL CONSUMPTION

333.56 (248.73)	2099	17.62 (66.68)	0.370 (0.225)	18.93 (3.73)	0.34 (1.29)	Air temperature
291.11 (217.08)	2155	15.35 (58.11)	0.369 (0.225)	18.96 (3.74)	0.29 (1.08)	73°F (23°C)
219.52 (163.69)	2167	11.95 (45.23)	0.381 (0.232)	18.37 (3.62)	0.20 (0.76)	Relative humidity
147.08 (109.68)	2178	8.85 (33.49)	0.421 (0.256)	16.63 (3.28)	0.17 (0.63)	34%
73.91 (55.11)	2189	6.22 (23.54)	0.589 (0.358)	11.89 (2.34)	0.12 (0.46)	Barometer
2.62 (1.95)	2201	3.57 (13.50)	9.530 (5.797)	0.73 (0.14)	0.12 (0.44)	29.06" Hg (98.41 kPa)

Maximum Torque - 1184 lb.-ft. (1605 Nm) at 1600 rpm

Maximum Torque Rise - 41.8%

Torque rise at 1680 engine rpm - 39%

Power increase at 1849 rpm - 12.5%

DRAWBAR PERFORMANCE

UNBALLASTED - FRONT DRIVE ENGAGED FUEL CONSUMPTION CHARACTERISTICS

Power Hp (kW)	Drawbar pull lbs (kN)	Speed mph (km/h)	Crank- shaft speed rpm	Slip %	Fuel Consumption lb/hp.hr (kg/kW.h)	D.E.F. Consumption Hp.hr/gal (kW.h/l)	D.E.F. Consumption lb/hp.hr (kg/kW.h)	Temp. °F(°C) cool- ing med	Air dry bulb	Barom. inch Hg (kPa)
Maximum Power—10th Gear-Manual mode										
297.72 (222.01)	21326 (94.86)	5.24 (8.42)	2100	5.4	0.412 (0.251)	17.01 (3.35)	0.009 (0.005)	204 (96)	54 (12)	29.26 (99.08)
75% of Pull at Maximum Power—10th Gear-Manual mode										
235.28 (175.45)	16120 (71.70)	5.47 (8.80)	2160	3.9	0.416 (0.253)	16.83 (3.32)	0.011 (0.006)	192 (89)	56 (13)	29.24 (99.02)
50% of Pull at Maximum Power—10th Gear-Manual mode										
159.47 (118.91)	10709 (47.64)	5.58 (8.98)	2174	2.5	0.450 (0.274)	15.56 (3.06)	0.013 (0.008)	189 (87)	59 (15)	29.21 (98.92)
75% of Pull at Reduced Engine Speed—5.7 mph (9.2 km/h) Auto mode										
234.59 (174.93)	16213 (72.12)	5.43 (8.74)	1373	3.8	0.388 (0.236)	18.03 (3.55)	0.012 (0.007)	212 (100)	57 (14)	29.24 (99.02)
50% of Pull at Reduced Engine Speed—5.8 mph (9.4 km/h) Auto mode										
159.62 (119.03)	10645 (47.33)	5.62 (9.04)	1403	2.5	0.392 (0.238)	17.87 (3.52)	0.009 (0.005)	191 (88)	60 (15)	29.19 (98.85)

Location of tests: Nebraska Tractor Test Laboratory,
University of Nebraska, Lincoln, Nebraska 68583-
0832

Dates of tests: October 9 - 28, 2015

Manufacturer: John Deere Tractor Works, 3500
East Donald St., P.O. Box 270, Waterloo Ia,
50704-0270

CONSUMABLE Fluids, OIL and TIME: Fuel
No. 2 Diesel **Specific gravity converted to 60°/60°F**
(15°/15°C) 0.8412 **Fuel weight** 7.004 lbs/gal (0.839
kg/l) **Diesel Exhaust Fluid (DEF)** 32% aqueous urea
solution **DEF weight** 9.071 lbs/gal (1.087 kg/l) **Oil**
SAE 10W-30 **API service classification** CJ-4
Transmission and hydraulic lubricant John Deere
Hy-Gard fluid **Front axle lubricant** John Deere
Hy-Gard fluid **Total time engine was operated:**
26.5 hours

ENGINE: Make John Deere **Diesel Type** six
cylinder vertical with two turbochargers, air to air
aftercooler and D.E.F (diesel exhaust fluid) exhaust
treatment **Serial No.** *RG6090U014981*
Crankshaft lengthwise **Rated engine speed** 2100
Bore and stroke 4.661" x 5.354" (118.4 mm x 136.0
mm) **Compression ratio** 16.0 to 1 **Displacement**
548 cu in (8984 ml) **Starting system** 12 volt
Lubrication pressure **Air cleaner** two paper
elements and aspirator **Oil filter** one full flow
cartridge **Oil cooler** engine coolant heat exchanger
for crankcase oil, radiator for hydraulic and
transmission oil **Fuel filter** one paper element and
water separator **Fuel cooler** radiator for pump
return fuel **Exhaust** DOC (diesel oxidation catalyst),
SCR (selective catalyst reduction) and regenerative
DPF (diesel particulate filter) integrated within a
vertical muffler **Cooling medium temperature**
control thermostat and variable speed fan

ENGINE OPERATING PARAMETERS: Fuel
rate: 116.8 - 126.5 lb/h (53.0 - 57.4 kg/h) **High idle:**
2190 - 2210 rpm **Turbo boost:** nominal 22.5 - 25.4
psi (155 - 175 kPa) as measured 23.8 psi (164 kPa)

CHASSIS: Type front wheel assist with duals
Serial No. *1RW8370RLES100013* **Tread width**
rear 60.0" (1524 mm) to 132.6" (3368 mm) front
64.0" (1625 mm) to 88.0" (2235 mm) **Wheelbase**
121.3" (3080 mm) **Hydraulic control system** direct
engine drive **Transmission** selective gear fixed
ratio with full range power shift **Nominal travel**
speeds mph (km/h) first 1.49 (2.40) second 1.73
(2.78) third 2.00 (3.22) fourth 2.32 (3.74) fifth 2.69
(4.33) sixth 3.12 (5.03) seventh 3.59 (5.77) eighth
4.16 (6.70) ninth 4.82 (7.75) tenth 5.58 (8.98)
eleventh 6.47 (10.42) twelfth 7.49 (12.06) thirteenth
8.70 (14.00) fourteenth 9.99 (16.08) fifteenth 11.60
(18.67) sixteenth 13.22 (21.27)

DRAWBAR PERFORMANCE
UNBALLASTED - FRONT DRIVE ENGAGED
MANUAL MODE - 2100 ENGINE RPM
DRAWBAR POWER AT SELECTED TRAVEL SPEED SETTINGS

Power Hp (kW)	Drawbar pull lbs (kN)	Speed mph (km/h)	Crank- shaft speed rpm	Slip %	Fuel Consumption lb/hp.hr (kg/kW.h)	D.E.F Consumption lb/hp.hr (kg/kW.h)	Temp.°F(°C) cool- ing med	Air dry bulb	Barom. inch Hg (kPa)	
					8th Gear					
261.23 (194.80)	27297 (121.42)	3.59 (5.78)	2143	14.5	0.456 (0.277)	15.36 (3.02)	0.010 (0.006)	216 (102)	64 (18)	28.68 (97.12)
					9th Gear					
292.14 (217.85)	24944 (110.96)	4.40 (7.07)	2100	8.1	0.421 (0.256)	16.64 (3.28)	0.009 (0.006)	208 (98)	54 (12)	29.25 (99.05)
					10th Gear					
297.72 (222.01)	21326 (94.86)	5.24 (8.42)	2100	5.4	0.412 (0.251)	17.01 (3.35)	0.009 (0.005)	204 (96)	54 (12)	29.26 (99.09)
					11th Gear					
302.13 (225.29)	18407 (81.88)	6.16 (9.91)	2100	4.2	0.406 (0.247)	17.26 (3.40)	0.009 (0.005)	207 (97)	46 (8)	29.25 (99.05)
					12th Gear					
303.39 (226.24)	15870 (70.59)	7.17 (11.54)	2099	3.6	0.404 (0.246)	17.32 (3.41)	0.009 (0.005)	208 (98)	48 (9)	29.26 (99.09)
					13th Gear					
301.68 (224.96)	13514 (60.11)	8.37 (13.47)	2099	3.1	0.406 (0.247)	17.27 (3.40)	0.009 (0.005)	208 (98)	50 (10)	29.26 (99.09)

seventeenth 15.35 (24.70) eighteenth 17.78 (28.61) nineteenth 20.64 (33.22) twentieth 23.89 (38.44) twenty-first 26.10 (42.00) twenty-second 26.10 (42.00) twenty-third 26.10 (42.00) electronically limited reverse 1.79 (2.88), 2.41 (3.88), 3.24 (5.21), 4.32 (6.95), 4.99 (8.03), 6.71 (10.80), 9.02 (14.51), 12.02 (19.35), 15.91 (25.60), 18.64 (30.00), 18.64 (30.00), 18.64 (30.00) electronically limited **Clutch** wet multiple disc hydraulically actuated by foot pedal **Brakes** wet multiple disc hydraulically operated by two foot pedals that can be locked together **Steering** hydrostatic **Power take-off** 1000 rpm at 1995 engine rpm **Unladen tractor mass** 27620 lb (12528 kg)

REPAIRS AND ADJUSTMENTS: No repairs or adjustments.

NOTE 1: The manufacturer declares that the average time between active regenerations is 50 hours, while operated in Auto Filter Cleaning Mode, at rated speed, full load, under steady state conditions.

REMARKS: All test results were determined from observed data obtained in accordance with official OECD, SAE and Nebraska test procedures. This tractor did not meet the manufacturer's remote hydraulic flow claim of 85 GPM (321l/min) with the dual pumps combined. The performance figures on this summary were taken from a test conducted under the OECD Code 2 test procedure.

We, the undersigned, certify that this is a true and correct report of official Tractor Test No. **2131**, Nebraska Summary 1001. December 10, 2015.

Roger M. Hoy
 Director

M.F. Kocher
 J.D. Luck
 P.J. Jasa
 Board of Tractor Test Engineers

TRACTOR SOUND LEVEL WITH CAB	Front Wheel Drive	
	Engaged dB(A)	Disengaged dB(A)
At no load in 9th gear	68.9	68.9
Transport speed-no load- 20th gear		73.1
Bystander in 20th gear		84.8

TIRES, BALLAST AND WEIGHT	With Ballast	Without Ballast
Rear Tires - No., size, ply & psi(kPa)	Six 480/80R50;***;12(85)	Four 480/80R50;***;12(85)
Ballast - Triples (total)	2420 lb (1098 kg)	None
- Cast Iron (total)	5865 lb (2659 kg)	None
Front Tires - No., size, ply & psi(kPa)	Four 420/85R34;***;19(130)	Two 420/85R34;***;26(180)
Ballast - Duals (total)	1600 lb (726 kg)	None
- Cast Iron (total)	2600 lb (1179 kg)	None
Height of Drawbar	21.0 in (535 mm)	21.0 in (535 mm)
Static Weight with operator - Rear	22980 lb (10423 kg)	16135 lb (7319 kg)
- Front	17300 lb (7847 kg)	11660 lb (5289 kg)
- Total	40280 lb (18270 kg)	27795 lb (12608 kg)

DRAWBAR PERFORMANCE
UNBALLASTED - FRONT DRIVE ENGAGED - AUTO MODE
(Loads based on 2100 engine rpm manual mode performance runs)

Power Hp (kW)	Drawbar pull lbs (kN)	Speed mph (km/h)	Crank- shaft speed rpm	Slip %	Fuel Consumption lb/hp.hr (kg/kW.h)	Hp.hr/gal (kW.h/l)	D.E.F Consumption lb/hp.hr (kg/kW.h)	Temp. °F(°C) cool- ing dry med bulb	Air dry bulb	Barom. inch Hg (kPa)
5.0 mph (8.0 km/h)										
288.57 (215.19)	24558 (109.24)	4.41 (7.10)	1814	7.8	0.410 (0.249)	17.10 (3.37)	0.013 (0.008)	215 (102)	55 (13)	29.25 (99.05)
5.6 mph (9.0 km/hr)										
298.54 (222.62)	21509 (95.67)	5.21 (8.38)	1804	5.7	0.398 (0.242)	17.61 (3.47)	0.013 (0.008)	216 (102)	56 (14)	29.25 (99.05)
6.5 mph (10.4 km/h)										
301.57 (224.88)	18514 (82.35)	6.11 (9.83)	1801	4.2	0.391 (0.238)	17.91 (3.53)	0.012 (0.007)	215 (102)	47 (9)	29.26 (99.09)
7.5 mph (12.0 km/h)										
303.21 (226.10)	16017 (71.24)	7.10 (11.43)	1791	3.7	0.391 (0.238)	17.90 (3.53)	0.012 (0.007)	216 (102)	49 (9)	29.26 (99.09)
8.7 mph (14.0 km/h)										
301.86 (225.09)	13599 (60.49)	8.32 (13.39)	1818	3.0	0.387 (0.235)	18.10 (3.57)	0.012 (0.007)	215 (101)	50 (10)	29.26 (99.09)

**DRAWBAR PERFORMANCE
UNBALLASTED - FRONT DRIVE ENGAGED
MANUAL MODE - 1850 ENGINE RPM**

Power Hp (kW)	Drawbar pull lbs (kN)	Speed mph (km/h)	Crank- shaft speed rpm	Slip %	Fuel Consumption lb/hp.hr (kg/kW.h)	Hp.hr/gal Consumption (kW.h/l)	D.E.F Consumption lb/hp.hr (kg/kW.h)	Temp. °F(°C) cool- ing med	Air dry bulb	Barom. inch Hg (kPa)
8th Gear										
261.69 (195.14)	27291 (121.39)	3.60 (5.79)	2142	14.3	0.455 (0.277)	15.39 (3.03)	0.010 (0.006)	216 (102)	64 (18)	28.68 (97.12)
9th Gear										
293.09 (218.56)	25725 (114.43)	4.28 (6.88)	2067	9.2	0.430 (0.261)	16.30 (3.21)	0.010 (0.006)	218 (103)	65 (18)	28.68 (97.12)
10th Gear										
315.69 (235.41)	24884 (110.69)	4.76 (7.66)	1965	8.1	0.424 (0.258)	16.52 (3.25)	0.008 (0.005)	218 (103)	66 (19)	28.68 (97.12)
11th Gear										
327.12 (243.93)	22810 (101.46)	5.38 (8.66)	1880	6.5	0.416 (0.253)	16.85 (3.32)	0.009 (0.005)	219 (104)	66 (19)	28.68 (97.12)
12th Gear										
336.39 (250.85)	20249 (90.07)	6.23 (10.03)	1850	4.9	0.404 (0.246)	17.32 (3.42)	0.008 (0.005)	217 (103)	52 (11)	29.26 (99.09)
13th Gear										
339.87 (253.44)	17451 (77.62)	7.31 (11.76)	1850	4.0	0.400 (0.243)	17.52 (3.45)	0.008 (0.005)	217 (103)	51 (11)	29.26 (99.09)
14th Gear										
339.10 (252.86)	15081 (67.08)	8.43 (13.57)	1849	3.4	0.402 (0.244)	17.44 (3.44)	0.008 (0.005)	216 (102)	52 (11)	29.26 (99.09)

**DRAWBAR PERFORMANCE
BALLASTED - FRONT DRIVE ENGAGED
MANUAL MODE - 1850 ENGINE RPM**

Power Hp (kW)	Drawbar pull lbs (kN)	Speed mph (km/h)	Crank- shaft speed rpm	Slip %	Fuel Consumption lb/hp.hr (kg/kW.h)	Hp.hr/gal (kW.h/l)	D.E.F Consumption lb/hp.hr (kg/kW.h)	Temp.°F(°C) cool- ing med	Air dry bulb	Barom. inch Hg (kPa)
5th Gear										
250.38 (186.71)	40341 (179.45)	2.33 (3.75)	2153	14.6	0.462 (0.281)	15.17 (2.99)	0.010 (0.006)	195 (91)	48 (9)	28.97 (98.10)
6th Gear										
286.40 (213.56)	38962 (173.31)	2.76 (4.44)	2088	10.3	0.434 (0.264)	16.14 (3.18)	0.010 (0.006)	209 (98)	49 (9)	28.97 (98.10)
7th Gear										
309.17 (230.55)	37434 (166.51)	3.10 (4.99)	2005	8.6	0.426 (0.259)	16.43 (3.24)	0.009 (0.005)	217 (103)	51 (11)	28.97 (98.10)
8th Gear										
325.91 (243.03)	35973 (160.02)	3.40 (5.47)	1873	7.5	0.420 (0.255)	16.69 (3.29)	0.009 (0.006)	218 (103)	53 (11)	28.98 (98.14)
9th Gear										
333.70 (248.84)	31578 (140.47)	3.96 (6.37)	1850	5.5	0.411 (0.250)	17.03 (3.36)	0.009 (0.005)	218 (103)	55 (13)	28.98 (98.14)
10th Gear										
334.83 (249.68)	27022 (120.20)	4.65 (7.48)	1850	4.4	0.409 (0.248)	17.15 (3.38)	0.008 (0.005)	218 (103)	56 (13)	28.98 (98.14)
11th Gear										
334.76 (249.63)	23082 (102.67)	5.44 (8.75)	1850	3.6	0.408 (0.248)	17.15 (3.38)	0.009 (0.006)	218 (103)	58 (14)	28.97 (98.10)
12th Gear										
339.67 (253.29)	20139 (89.58)	6.33 (10.18)	1850	3.1	0.404 (0.246)	17.34 (3.42)	0.008 (0.005)	217 (103)	58 (14)	28.97 (98.10)
13th Gear										
339.03 (252.81)	17244 (76.70)	7.37 (11.86)	1849	2.7	0.404 (0.246)	17.35 (3.42)	0.009 (0.005)	218 (103)	58 (14)	28.97 (98.10)
14th Gear										
334.20 (249.21)	14708 (65.42)	8.52 (13.71)	1854	2.3	0.409 (0.249)	17.10 (3.37)	0.008 (0.005)	218 (103)	59 (15)	28.97 (98.10)

HYDRAULIC PERFORMANCE

CATEGORY: IVN
 Quick Attach: Yes
 OECD Static test

	Lift cylinders	
Maximum force exerted through whole range:	20254 lbs (90.1 kN) 2x115 mm	15229 lbs (67.7 kN) 2x100 mm
	85 cc pump 85 cc and 35cc pumps combined	
i) Sustained pressure at compensator cutoff:	2968 psi (205 bar)	2941 psi (203 bar)
	three outlet sets combined	
ii) Pump delivery rate at minimum pressure and rated engine speed:	61.1 GPM(231.4l/min)	84.2 GPM(318.7l/min)
iii) Pump delivery rate at maximum hydraulic power:	60.8 GPM(230.3l/min)	80.0 GPM(302.9l/min)
Delivery pressure:	2549 psi (176 bar)	2114 psi (146 bar)
Power:	90.5 HP (67.5 kW)	98.7 HP (73.6 kW)
	single outlet set	
ii) Pump delivery rate at minimum pressure and rated engine speed:	36.7 GPM(138.8l/min)	42.9 GPM(162.5 l/min)
iii) Pump delivery rate at maximum hydraulic power:	35.7 GPM(135.1l/min)	41.5 GPM(157.2 l/min)
Delivery pressure:	2391 psi (165 bar)	2301 psi (159 bar)
Power:	49.8 HP (37.1 kW)	55.8 HP (41.6 kW)

	HITCH DIMENSIONS AS TESTED—NO LOAD	
	inch	mm
A	28.5	725
B	20.5	520
C	20.9	532
D	18.9	480
E	12.0	304
F	14.4	365
G	38.2	970
H	9.1	230
I	23.6	599
J	23.8	605
K	28.7	730
L	52.8	1340
*L'	58.7	1490
M	25.9	657
N	40.1	1019
O	9.1	230
P	50.1	1272
Q	41.5	1055
R	45.7	1160

*L' to Quick Attach ends

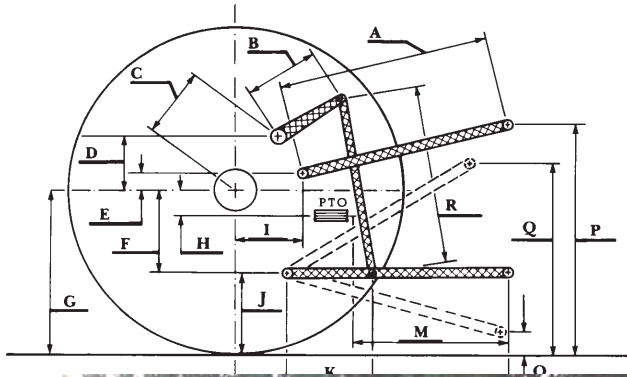

JOHN DEERE 8370R DIESEL