

NEBRASKA OECD TRACTOR TEST 2221-SUMMARY 1168

JOHN DEERE 7R 330 DIESEL

e23 TRANSMISSION

POWER TAKE-OFF PERFORMANCE

Power HP (kW)	Crank shaft speed rpm	Diesel Consumption		D.E.F. Consumption		Mean Atmospheric Conditions
		Gal/hr (l/h)	lb/hp.hr (kg/kW.h)	Hp.hr/gal (kW.h/l)	Gal/hr (l/h)	
MAXIMUM POWER AND FUEL CONSUMPTION						
Rated Engine Speed—(PTO speed—1077 rpm)						
271.52 (202.47)	2100	14.33 (54.24)	0.368 (0.224)	18.95 (3.73)	0.73 (2.77)	Fuel used during active exhaust regeneration-1.23 gal (4.66 l) (see note 1, p.2)
Standard Power Take-off Speed (1000 rpm)						
296.93 (221.42)	1950	15.23 (57.66)	0.358 (0.218)	19.50 (3.84)	0.76 (2.88)	
Maximum Power (1 hour)						
303.69 (226.46)	1751	15.21 (57.57)	0.350 (0.213)	19.97 (3.93)	0.75 (2.85)	

VARYING POWER AND FUEL CONSUMPTION

271.52 (202.47)	2100	14.33 (54.24)	0.368 (0.224)	18.95 (3.73)	0.73 (2.77)	Air temperature
236.97 (176.71)	2157	12.87 (48.72)	0.379 (0.231)	18.41 (3.63)	0.70 (2.66)	75°F (24°C)
178.67 (133.23)	2167	10.33 (39.10)	0.404 (0.246)	17.30 (3.41)	0.53 (2.01)	Relative humidity
119.71 (89.27)	2179	7.94 (30.05)	0.463 (0.282)	15.08 (2.97)	0.30 (1.13)	26%
60.23 (44.91)	2191	5.86 (22.18)	0.679 (0.413)	10.28 (2.02)	0.17 (0.66)	Barometer
1.61 (1.20)	2198	4.54 (17.20)	19.648 (11.951)	0.36 (0.07)	0.22 (0.82)	28.70" Hg (97.19 kPa)

Maximum torque - 996 lb.-ft. (1350 Nm) at 1552 rpm

Maximum torque rise - 46.6%

Torque rise at 1683 engine rpm - 40%

Power increase at 1751 engine rpm - 11.9%

DRAWBAR PERFORMANCE

UNBALLASTED - FRONT DRIVE ENGAGED FUEL CONSUMPTION CHARACTERISTICS

Power Hp (kW)	Drawbar pull lbs (kN)	Speed mph (km/h)	Crank- shaft speed rpm	Slip %	Fuel Consumption lb/hp.hr (kg/kW.h)	D.E.F. Consumption lb/hp.hr (kW.h/l)	Temp. °F (°C) cool- ing med	Air dry bulb (kPa)	Barom. inch Hg (kPa)	
Power at Rated Engine Speed—11th Gear-Manual mode										
264.21 (197.02)	16569 (73.70)	5.98 (9.62)	2100	3.6	0.400 (0.243)	17.45 (3.44)	0.027 (0.016)	217 (103)	53 (12)	29.00 (98.19)
75% of Pull at Rated Engine Speed—11th Gear-Manual mode										
204.70 (152.64)	12389 (55.11)	6.20 (9.97)	2159	2.7	0.425 (0.258)	16.44 (3.24)	0.029 (0.018)	217 (103)	68 (20)	28.99 (98.15)
50% of Pull at Rated Engine Speed—11th Gear-Manual mode										
138.28 (103.12)	8244 (36.67)	6.29 (10.12)	2172	1.8	0.470 (0.286)	14.87 (2.93)	0.028 (0.017)	216 (102)	68 (20)	28.98 (98.14)
75% of Pull at Reduced Engine Speed—6.5 mph (10.4 km/h)-Auto mode										
204.36 (152.39)	12282 (54.63)	6.24 (10.04)	1429	2.7	0.384 (0.234)	18.17 (3.58)	0.018 (0.011)	217 (103)	69 (21)	28.98 (98.14)
50% of Pull at Reduced Engine Speed—6.5 mph (10.4 km/h)-Auto mode										
138.54 (103.31)	8251 (36.70)	6.30 (10.14)	1237	1.8	0.407 (0.248)	17.15 (3.38)	0.015 (0.009)	216 (102)	69 (21)	28.98 (98.12)

Location of tests: Nebraska Tractor Test Laboratory, University of Nebraska, Lincoln, Nebraska 68583-0832

Dates of tests: September 17 to October 9, 2020

Manufacturer: John Deere Tractor Works, 3500 East Donald Street, P.O. Box 270, Waterloo Ia, 50704-0270

CONSUMABLE Fluids, OIL and TIME: Fuel No. 2 Diesel **Specific gravity converted to 60°/60°F (15°/15°C)** 0.8386 **Fuel weight** 6.982 lbs/gal (0.837 kg/l) **Diesel Exhaust Fluid (DEF)** 32% aqueous urea solution **DEF weight** 9.071 lbs/gal (1.087 kg/l) **Oil SAE 10W-30 API service classification CK-4 Transmission and hydraulic lubricant** John Deere Hy-Gard fluid **Front axle lubricant** John Deere Hy-Gard fluid **Total time engine was operated:** 36.5 hours

ENGINE: Make John Deere **Diesel Type** six cylinder vertical with turbocharger, air to air aftercooler and D.E.F. (diesel exhaust fluid) exhaust treatment **Serial No.** *RG6090U086859* **Crankshaft** lengthwise **Rated engine speed** 2100 **Bore and stroke** 4.661" x 5.354" (118.4 mm x 136.0 mm) **Compression ratio** 16.0 to 1 **Displacement** 548 cu in (8984 ml) **Starting system** 12 volt **Lubrication** pressure **Air cleaner** two paper elements and aspirator **Oil filter** one full flow cartridge **Oil cooler** engine coolant heat exchanger for crankcase oil, radiator for hydraulic and transmission oil **Fuel filter** one paper element and prestrainer **Fuel cooler** radiator for pump return fuel **Exhaust** regenerative particulate filter integrated within a vertical muffler **Cooling medium temperature control** thermostat and variable speed fan

ENGINE OPERATING PARAMETERS: Fuel rate: Stationary PTO operations (310 engine hp) 94.4 - 102.0 lb/h (42.8 - 46.3 kg/h) Drawbar operations (330 engine hp) 100.5 - 108.7 lb/h (45.6 - 49.3 kg/h) **High idle:** 2190 - 2210 rpm **Turbo boost:** nominal 23.2 - 26.8 psi (160 - 185 kPa) as measured 25.2 psi (174 kPa)

CHASSIS: Type front wheel assist with duals **Serial No.** *1RW7330SALC110411* **Tread width** rear 60.0" (1524 mm) to 128.9" (3272 mm) front 60.0" (1524 mm) to 88.0" (2235 mm) **Wheelbase** 115.2" (2925 mm) **Hydraulic control system** direct engine drive **Transmission** selective gear fixed ratio with full range operator controlled power shift **Nominal travel speeds mph (km/h)** first 1.50 (2.42) second 1.74 (2.80) third 2.01 (3.23) fourth 2.32 (3.73) fifth 2.67 (4.29) sixth 3.08 (4.96) seventh 3.53 (5.68) eighth 4.08 (6.56) ninth 4.66 (7.50) tenth 5.38 (8.66) eleventh 6.21 (10.00) twelfth 7.15 (11.51) thirteenth 8.26 (13.29) fourteenth 9.45 (15.21) fifteenth 10.92 (17.57)

DRAWBAR PERFORMANCE
UNBALLASTED - FRONT DRIVE ENGAGED
MANUAL MODE - 2100 ENGINE RPM
DRAWBAR POWER IN SELECTED GEARS

Power Hp (kW)	Drawbar pull lbs (kN)	Speed mph (km/h)	Crank- shaft speed rpm	Slip %	Fuel Consumption lb/hp.hr (kg/kW.h)	Hp.hr/gal (kW.h/l)	D.E.F. Consumption lb/hp.hr (kg/kW.h)	Temp. °F(°C) cool- ing med	Air dry bulb	Barom. inch Hg (kPa)
					7th Gear					
211.47 (157.69)	25364 (112.82)	3.13 (5.04)	2154	13.5	0.457 (0.278)	15.26 (3.01)	0.032 (0.019)	218 (103)	51 (11)	29.08 (98.48)
					8th Gear					
241.25 (179.90)	24409 (108.57)	3.71 (5.97)	2124	10.0	0.435 (0.265)	16.05 (3.16)	0.030 (0.018)	218 (103)	54 (12)	29.09 (98.51)
					9th Gear					
256.31 (191.13)	22014 (97.92)	4.37 (7.02)	2100	6.0	0.415 (0.252)	16.82 (3.31)	0.026 (0.016)	218 (103)	57 (14)	29.00 (98.21)
					10th Gear					
260.88 (194.53)	19132 (85.10)	5.11 (8.22)	2100	4.7	0.406 (0.247)	17.21 (3.39)	0.027 (0.016)	217 (103)	59 (15)	29.00 (98.21)
					11th Gear					
264.21 (197.02)	16569 (73.70)	5.98 (9.62)	2100	3.6	0.400 (0.243)	17.45 (3.44)	0.027 (0.016)	217 (103)	53 (12)	29.00 (98.19)
					12th Gear					
262.22 (195.53)	14223 (63.27)	6.91 (11.12)	2099	3.0	0.404 (0.246)	17.29 (3.41)	0.029 (0.017)	218 (103)	52 (11)	29.00 (98.21)
					13th Gear					
261.74 (195.18)	12233 (54.41)	8.02 (12.91)	2100	2.6	0.404 (0.246)	17.29 (3.41)	0.029 (0.017)	217 (103)	55 (13)	29.00 (98.21)

TRACTOR SOUND LEVEL WITH CAB	Front Wheel Drive	
	Engaged dB(A)	Disengaged dB(A)
At no load in 9th gear	69.3	69.3
Transport speed - no load - 21st gear		72.2
Bystander in 21st gear		84.0

Horizontal distance of drawbar hitch point behind rear wheel axis - 47.4"(1203 mm)

TIRES, BALLAST AND WEIGHT	With Ballast	Without Ballast
Rear Tires - No., size, ply & psi(kPa)	Four 480/80R50;***;16(110)	Four 480/80R50;***;11(75)
Ballast - Liquid (total)	None	None
- Cast Iron (total)	5795 lb (2629 kg)	None
Front Tires - No., size, ply & psi(kPa)	Two 420/85R34;***;29(200)	Two 420/85R34;***;16(110)
Ballast - Liquid (total)	None	None
- Cast Iron (total)	2555 lb (1159 kg)	None
Height of Drawbar	20.5 in (520 mm)	20.5 in (520 mm)
Static Weight with operator - Rear	21325 lb (9673 kg)	16710 lb (7580 kg)
- Front	12445 lb (5645 kg)	8710 lb (3950 kg)
- Total	33770 lb(15318 kg)	25420 lb(11530 kg)

sixteenth 12.68 (20.41) seventeenth 14.65 (23.57) eighteenth 16.91 (27.22) nineteenth 19.54 (31.44) twentieth 22.48 (36.17) twenty-first 25.96 (41.78) twenty-second 26.10 (42.00) twenty-third 26.10 (42.00) electronically limited reverse 1.41 (2.27), 1.88 (3.02), 2.50 (4.02), 3.30 (5.31), 3.77 (6.07), 5.03 (8.10), 6.69 (10.76), 8.84 (14.22), 11.86 (19.08), 15.81 (25.45), 18.64 (30.00) electronically limited **Clutch** wet multiple disc hydraulically actuated by foot pedal **Brakes** wet multiple disc hydraulically operated by two foot pedals that can be locked together **Steering** hydrostatic **Power take-off** 1000 rpm at 1950 engine rpm **Unladen tractor mass** 25245 lb (11451 kg)

REPAIRS AND ADJUSTMENTS: No repairs or adjustments.

NOTE 1: The manufacturer declares that the average time between active regenerations is 40 hours. A 2% power increase was observed during the active regeneration.

NOTE 2: In stationary PTO operation, this model operates in a derated power mode.

REMARKS: All test results were determined from observed data obtained in accordance with official OECD, SAE and Nebraska test procedures. This tractor fell 1.2% short of meeting the manufacturer's remote hydraulic flow claim of 59 GPM (223.3 l/min) with the 85 cc pump. The performance figures on this summary were taken from a test conducted under the OECD Code 2 test procedure.

We, the undersigned, certify that this is a true and correct report of official Tractor Test No. 2221, Nebraska Summary 1168, March 1, 2021.

Roger M. Hoy
 Director

M.F. Kocher
 P.J. Jasa
 J.D. Luck
 Board of Tractor Test Engineers

DRAWBAR PERFORMANCE
UNBALLASTED - FRONT DRIVE ENGAGED - AUTO MODE
(Loads based on 2100 engine rpm manual mode performance runs)
DRAWBAR POWER AT SELECTED TRAVEL SPEEDS

Power Hp (kW)	Drawbar pull lbs (kN)	Speed mph (km/h)	Crank- shaft speed rpm	Slip %	Fuel Consumption		D.E.F. Consumption	Temp. °F(°C)		Barom. inch Hg (kPa)
					lb/hp.hr (kg/kW.h)	Hp.hr/gal (kW.h/l)	lb/hp.hr (kg/kW.h)	cool- ing med	Air dry bulb	
3.5mph (5.6 km/h)										
205.36 (153.14)	24929 (110.89)	3.09 (4.97)	1352	10.8	0.404 (0.246)	17.28 (3.40)	0.023 (0.014)	217 (103)	51 (11)	29.09 (98.49)
4.1 mph (6.6 km/h)										
238.36 (177.75)	24404 (108.55)	3.66 (5.89)	1594	10.3	0.408 (0.248)	17.13 (3.37)	0.020 (0.012)	217 (103)	55 (13)	29.09 (98.51)
4.7 mph (7.6 km/h)										
255.75 (190.71)	21785 (96.90)	4.41 (7.09)	1588	6.1	0.391 (0.238)	17.86 (3.52)	NA (NA)	218 (103)	59 (15)	29.00 (98.21)
5.3 mph (8.6 km/h)										
260.13 (193.98)	19340 (86.03)	5.05 (8.12)	1562	4.9	0.389 (0.237)	17.93 (3.53)	0.023 (0.014)	217 (103)	61 (16)	29.00 (98.21)
6.2 mph (10.0 km/h)										
262.64 (195.85)	16577 (73.74)	5.94 (9.56)	1571	3.6	0.383 (0.233)	18.23 (3.59)	0.024 (0.014)	217 (103)	54 (12)	29.00 (98.21)
7.2 mph (11.6 km/h)										
262.20 (195.52)	14168 (63.02)	6.94 (11.17)	1594	3.0	0.382 (0.232)	18.30 (3.60)	NA (NA)	217 (103)	52 (11)	28.99 (98.17)
8.3 mph (13.4 km/h)										
261.52 (195.01)	12179 (54.17)	8.05 (12.96)	1594	2.5	0.386 (0.235)	18.08 (3.56)	NA (NA)	217 (103)	56 (13)	29.00 (98.21)

DRAWBAR PERFORMANCE
UNBALLASTED - FRONT DRIVE ENGAGED - 1800 ENGINE RPM
MAXIMUM POWER IN SELECTED GEARS

Power Hp (kW)	Drawbar pull lbs (kN)	Speed mph (km/h)	Crank- shaft speed rpm	Slip %	Fuel Consumption lb/hp.hr (kg/kW.h)	Hp.hr/gal (kW.h/l)	D.E.F. Consumption lb/hp.hr (kg/kW.h)	Temp. °F(°C) cool- ing med	Air dry bulb	Barom. inch Hg (kPa)
7th Gear										
211.74 (157.89)	25362 (112.81)	3.14 (5.05)	2153	13.3	0.457 (0.278)	15.27 (3.01)	0.031 (0.019)	218 (103)	51 (11)	29.08 (98.46)
8th Gear										
241.87 (180.36)	24412 (108.59)	3.72 (5.98)	2131	10.0	0.434 (0.264)	16.11 (3.17)	0.030 (0.018)	217 (103)	53 (12)	29.09 (98.51)
9th Gear										
261.51 (195.01)	23422 (104.19)	4.19 (6.74)	2055	8.1	0.418 (0.255)	16.68 (3.29)	0.028 (0.017)	217 (103)	57 (14)	29.10 (98.53)
10th Gear										
279.89 (208.71)	22264 (99.04)	4.72 (7.59)	1980	7.0	0.404 (0.246)	17.27 (3.40)	0.025 (0.015)	217 (103)	58 (14)	29.10 (98.54)
11th Gear										
286.18 (213.40)	21576 (95.97)	4.98 (8.01)	1800	6.4	0.400 (0.243)	17.46 (3.44)	0.025 (0.015)	218 (103)	59 (15)	29.10 (98.54)
12th Gear										
290.67 (216.75)	18777 (83.52)	5.81 (9.34)	1800	4.9	0.393 (0.239)	17.75 (3.50)	0.025 (0.015)	218 (103)	59 (15)	29.10 (98.54)
13th Gear										
293.15 (218.60)	16245 (72.26)	6.77 (10.90)	1800	4.1	0.391 (0.238)	17.87 (3.52)	0.025 (0.015)	218 (103)	60 (15)	29.10 (98.54)
14th Gear										
294.05 (219.27)	14151 (62.95)	7.79 (12.54)	1800	3.4	0.389 (0.237)	17.93 (3.53)	0.024 (0.014)	218 (103)	60 (16)	29.10 (98.54)
15th Gear										
293.24 (218.67)	12152 (54.05)	9.05 (14.56)	1800	2.9	0.390 (0.237)	17.91 (3.53)	0.024 (0.015)	218 (103)	61 (16)	29.10 (98.54)

Lugging ability in 13th gear

Crankshaft speed rpm	2100	1999	1899	1800	1700	1499	1300	1100
Pull-lbs (kN)	12171 (54.14)	13892 (61.79)	15040 (66.90)	16003 (71.18)	16846 (74.93)	17649 (78.51)	17516 (77.92)	16511 (73.44)
Increase in pull%	0	14	24	31	38	45	44	36
Power-Hp (kW)	260.00 (193.88)	281.42 (209.85)	288.57 (215.19)	289.99 (216.24)	287.37 (214.29)	264.70 (197.38)	227.72 (169.81)	182.16 (135.84)
Speed-mph (km/h)	8.01 (12.89)	7.60 (12.23)	7.20 (11.58)	6.80 (10.94)	6.40 (10.30)	5.63 (9.05)	4.88 (7.85)	4.14 (6.66)
Slip %	2.7	3.1	3.4	3.7	4.0	4.4	4.4	4.0

DRAWBAR PERFORMANCE
BALLASTED - FRONT DRIVE ENGAGED - 1800 ENGINE RPM
MAXIMUM POWER IN SELECTED GEARS

Power Hp (kW)	Drawbar pull lbs (kN)	Speed mph (km/h)	Crank- shaft speed rpm	Slip %	Fuel Consumption lb/hp.hr (kg/kW.h)	Hp.hr/gal (kW.h/l)	D.E.F. Consumption lb/hp.hr (kg/kW.h)	Temp.°F(°C) cool- ing med	Air dry bulb	Barom. inch Hg (kPa)
6th Gear										
235.62 (175.70)	32713 (145.51)	2.71 (4.35)	2114	13.0	0.445 (0.270)	15.71 (3.09)	0.033 (0.020)	219 (104)	46 (8)	29.03 (98.31)
7th Gear										
258.24 (192.57)	30975 (137.78)	3.13 (5.04)	2050	9.1	0.419 (0.255)	16.66 (3.28)	0.031 (0.019)	219 (104)	49 (9)	29.03 (98.31)
8th Gear										
276.14 (205.91)	29537 (131.38)	3.51 (5.65)	1959	7.6	0.408 (0.248)	17.09 (3.37)	0.029 (0.018)	219 (104)	50 (10)	29.04 (98.32)
9th Gear										
286.18 (213.40)	28186 (125.38)	3.81 (6.13)	1844	6.7	0.400 (0.244)	17.44 (3.44)	0.026 (0.016)	218 (103)	50 (10)	29.05 (98.37)
10th Gear										
291.13 (217.09)	25095 (111.63)	4.35 (7.00)	1800	5.4	0.392 (0.239)	17.80 (3.51)	0.027 (0.016)	218 (103)	50 (10)	29.05 (98.37)
11th Gear										
292.56 (218.16)	21596 (96.06)	5.08 (8.18)	1800	4.4	0.390 (0.237)	17.89 (3.52)	0.027 (0.016)	218 (103)	50 (10)	29.05 (98.37)
12th Gear										
294.77 (219.81)	18774 (83.51)	5.89 (9.48)	1800	3.7	0.389 (0.236)	17.97 (3.54)	0.028 (0.017)	218 (103)	50 (10)	29.06 (98.41)
13th Gear										
292.45 (218.08)	16032 (71.31)	6.84 (11.01)	1800	3.1	0.390 (0.237)	17.92 (3.53)	0.027 (0.017)	218 (103)	51 (11)	29.06 (98.41)
14th Gear										
292.21 (217.90)	13934 (61.98)	7.87 (12.66)	1800	2.6	0.390 (0.237)	17.92 (3.53)	0.026 (0.016)	218 (103)	52 (11)	29.07 (98.44)
15th Gear										
291.49 (217.36)	11994 (53.35)	9.11 (14.66)	1800	2.3	0.393 (0.239)	17.76 (3.50)	0.027 (0.016)	218 (103)	52 (11)	29.07 (98.44)

HYDRAULIC PERFORMANCE

CATEGORY: III

Quick Attach: Yes

OECD Static test

	<u>lift cylinders</u>	
Maximum force exerted through whole range:	15862 lbs (70.6 kN) (2x100 mm)	18302 lbs (81.4 kN) (1x100 mm & 1x115 mm)
	<u>63 cc pump</u> <u>85 cc pump</u>	
i) Sustained pressure at compensator cutoff:	2918 psi (201 bar)	2931 psi (202 bar)
	three outlet sets combined	
ii) Pump delivery rate at minimum pressure and rated engine speed:	44.6 GPM (168.9 l/min)	58.3 GPM (220.7 l/min)
iii) Pump delivery rate at maximum hydraulic power:	44.3 GPM (167.6 l/min)	57.5 GPM (217.6 l/min)
Delivery pressure:	2639 psi (182 bar)	2571 psi (177 bar)
Power:	68.2 HP (50.8 kW)	86.2 HP (64.3 kW)
	single outlet set	
ii) Pump delivery rate at minimum pressure and rated engine speed:	36.9 GPM (139.6 l/min)	36.4 GPM (137.9 l/min)
iii) Pump delivery rate at maximum hydraulic power:	35.4 GPM (134.1 l/min)	35.4 GPM (134.0 l/min)
Delivery pressure:	2276 psi (157 bar)	2244 psi (155 bar)
Power:	47.0 HP (35.1 kW)	46.4 HP (34.6 kW)

HITCH DIMENSIONS AS TESTED—NO LOAD

	inch	mm
A	28.0	710
B	20.5	520
C	22.9	581
D	18.9	480
E	7.3	185
F	14.4	365
G	38.8	985
H	3.5	90
I	22.4	570
J	24.4	620
K	29.3	745
L	52.0	1321
*L'	56.0	1423
M	28.0	712
N	43.4	1102
O	9.0	230
P	51.9	1319
Q	39.4	1001
R	44.9	1140

*L' to Quick Attach ends

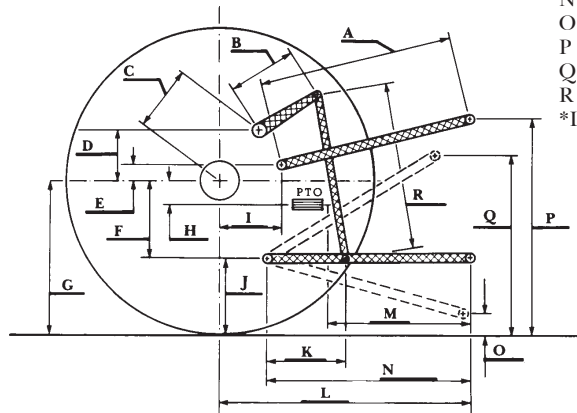

RECOMMENDED CITATION FORMAT:

NTTL.(2021). Nebraska OECD tractor test 2221 for John Deere 7R 330 e23 Diesel. Lincoln, NE:Nebraska Tractor Test Laboratory. Retrieved from <http://tractortestlab.unl.edu>



JOHN DEERE 7R 330 DIESEL

Institute of Agriculture and Natural Resources
University of Nebraska–Lincoln