

NEBRASKA OECD TRACTOR TEST 2090A - SUMMARY 939A

JOHN DEERE 7230R DIESEL

ALSO JOHN DEERE 7R 230 DIESEL

e23 TRANSMISSION

POWER TAKE-OFF PERFORMANCE

Power HP (kW)	Crank shaft speed rpm	Diesel Consumption		D.E.F. Consumption		Mean Atmospheric Conditions
		Gal/hr (l/h)	lb/hp.hr (kg/kW.h)	Hp.hr/gal (kW.h/l)	Gal/hr (l/h)	
MAXIMUM POWER AND FUEL CONSUMPTION						
Rated Engine Speed—(PTO speed—1077 rpm)						
198.79 (148.23)	2100	11.25 (42.57)	0.397 (0.241)	17.68 (3.48)	0.31 (1.17)	Fuel used during active exhaust regeneration-1.76 gal (6.66 l) (see note 1, p.2)
Standard Power Take-off Speed (1000 rpm)						
223.09 (166.36)	1950	12.34 (46.70)	0.388 (0.236)	18.08 (3.56)	0.33 (1.24)	
Maximum Power (1 hour)						
227.56 (169.69)	1701	12.31 (46.60)	0.380 (0.231)	18.49 (3.64)	0.32 (1.20)	

VARYING POWER AND FUEL CONSUMPTION

198.79 (148.23)	2100	11.25 (42.57)	0.397 (0.241)	17.68 (3.48)	0.31 (1.17)	Air temperature
173.38 (129.29)	2156	10.04 (38.02)	0.407 (0.247)	17.26 (3.40)	0.30 (1.12)	74°F (23°C)
130.62 (97.40)	2162	7.97 (30.18)	0.428 (0.261)	16.38 (3.23)	0.24 (0.92)	Relative humidity
87.43 (65.20)	2175	6.25 (23.64)	0.501 (0.305)	14.00 (2.76)	0.13 (0.51)	61%
43.95 (32.77)	2185	4.49 (17.00)	0.717 (0.436)	9.79 (1.93)	0.09 (0.35)	Barometer
2.68 (2.00)	2193	2.73 (10.33)	7.148 (4.348)	0.98 (0.19)	0.14 (0.52)	28.76" Hg (97.39 kPa)

Maximum torque - 732 lb.-ft. (993 Nm) at 1400 rpm
 Maximum torque rise - 47.3%
 Torque rise at 1680 engine rpm - 42%
 Power increase at 1701 engine rpm - 14.5%

DRAWBAR PERFORMANCE UNBALLASTED - FRONT DRIVE ENGAGED FUEL CONSUMPTION CHARACTERISTICS

Power Hp (kW)	Drawbar pull lbs (kN)	Speed mph (km/h)	Crank- shaft speed rpm	Slip %	Fuel Consumption lb/hp.hr (kg/kW.h)	Hp.hr/gal (kW.h/l)	Temp. °F (°C) cool- ing med	Air dry bulb	Barom. inch Hg (kPa)
Power at Rated Engine Speed—10th Gear - Manual mode									
179.37 (133.75)	13215 (58.78)	5.09 (8.19)	2100	2.6	0.437 (0.266)	16.05 (3.16)	220 (104)	70 (21)	28.76 (97.39)
75% of Pull at Rated Engine Speed—10th Gear- Manual mode									
139.07 (103.70)	9904 (44.05)	5.27 (8.48)	2157	1.9	0.464 (0.282)	15.13 (2.98)	219 (104)	82 (28)	28.75 (97.36)
50% of Pull at Rated Engine Speed—10th Gear- Manual mode									
94.02 (70.11)	6620 (29.44)	5.33 (8.58)	2169	1.3	0.517 (0.315)	13.57 (2.67)	217 (103)	83 (28)	28.74 (97.33)
75% of Pull at Reduced Engine Speed—5.3 mph (8.6 km/h)-Auto mode									
139.13 (103.75)	9947 (44.25)	5.25 (8.45)	1400	1.9	0.435 (0.264)	16.15 (3.18)	218 (103)	82 (28)	28.74 (97.33)
50% of Pull at Reduced Engine Speed—5.3 mph (8.6 km/h)-Auto mode									
93.81 (69.95)	6662 (29.63)	5.28 (8.50)	1224	1.3	0.458 (0.279)	15.31 (3.02)	216 (102)	83 (28)	28.74 (97.33)

Location of tests: Nebraska Tractor Test Laboratory, University of Nebraska, Lincoln, Nebraska 68583-0832

Dates of tests: June 24 -27, 2014

Manufacturer: John Deere Tractor Works, 3500 East Donald Street, P.O. Box 270, Waterloo Ia, 50704-0270

CONSUMABLE Fluids, OIL and TIME: Fuel No. 2 Diesel **Specific gravity converted to 60°/60°F (15°/15°C)** 0.8429 **Fuel weight** 7.018 lbs/gal (0.841 kg/l) **Diesel Exhaust Fluid (DEF)** 32% aqueous urea solution **DEF weight** 9.071 lbs/gal (1.087 kg/l) **Oil SAE 15W-40 API service classification CJ-4 Transmission and hydraulic lubricant** John Deere Hy-Gard fluid **Front axle lubricant** John Deere Hy-Gard fluid **Total time engine was operated:** 19.5 hours

ENGINE: Make John Deere **Diesel Type** six cylinder vertical with two turbochargers, air to air aftercooler and D.E.F. (diesel exhaust fluid) exhaust treatment **Serial No.*** PE6068U000894* **Crankshaft** lengthwise **Rated engine speed** 2100 **Bore and stroke** 4.19" x 5.00" (106.5 mm x 127.0 mm) **Compression ratio** 16.0 to 1 **Displacement** 414 cu in (6788 ml) **Starting system** 12 volt **Lubrication** pressure **Air cleaner** two paper elements and aspirator **Oil filter** one full flow cartridge **Oil cooler** engine coolant heat exchanger for crankcase oil, radiator for hydraulic and transmission oil **Fuel filter** one paper element and prestrainer **Fuel cooler** radiator for pump return fuel **Exhaust** regenerative particulate filter integrated within a vertical muffler **Cooling medium temperature control** 2 thermostats and variable speed fan

ENGINE OPERATING PARAMETERS: Fuel rate: 74.1 - 80.5 lb/h (33.6 - 36.5 kg/h) **High idle:** 2150 - 2250 rpm **Turbo boost:** nominal 25.4 - 28.3 psi (175 - 195 kPa) as measured 27.1 psi (186 kPa)

CHASSIS: Type front wheel assist with duals **Serial No.*** 1RW7230RCES081515* **Tread width** rear 60.0" (1524 mm) to 128.9" (3272 mm) front 60.0" (1524 mm) to 88.0" (2235 mm) **Wheelbase** 115.2" (2925 mm) **Hydraulic control system** direct engine drive **Transmission** selective gear fixed ratio with full range operator controlled power shift **Nominal travel speeds mph (km/h)** first 1.46 (2.35) second 1.69 (2.72) third 1.95 (3.14) fourth 2.26 (3.63) fifth 2.59 (4.17) sixth 2.99 (4.81) seventh 3.43 (5.52) eighth 3.96 (6.37) ninth 4.53 (7.29) tenth 5.23 (8.41) eleventh 6.04 (9.72) twelfth 6.95 (11.18) thirteenth 8.02 (12.91) fourteenth 9.18 (14.78) fifteenth 10.61 (17.07) sixteenth 12.32 (19.83) seventeenth 14.23 (22.90) eighteenth 16.43 (26.44) nineteenth 18.98 (30.55) twentieth 21.84 (35.14) twenty-first 25.23 (40.60) twenty-second 26.10 (42.00) twenty-third 26.10 (42.00) electronically limited

DRAWBAR PERFORMANCE
UNBALLASTED - FRONT DRIVE ENGAGED
MANUAL MODE - 2100 ENGINE RPM
DRAWBAR POWER IN SELECTED GEARS

Power Hp (kW)	Drawbar pull lbs (kN)	Speed mph (km/h)	Crank- shaft speed rpm	Slip %	Fuel Consumption lb/hp.hr (kg/kW.h)	Temp. °F (°C) cool- ing med	Air dry bulb	Barom. inch Hg (kPa)	
6th Gear									
149.90 (111.78)	20910 (93.01)	2.69 (4.33)	2151	14.4	0.501 (0.304)	14.02 (2.76)	219 (104)	84 (29)	28.60 (96.85)
7th Gear									
170.48 (127.12)	19997 (88.95)	3.20 (5.15)	2100	6.7	0.461 (0.280)	15.24 (3.00)	220 (104)	82 (28)	28.61 (96.88)
8th Gear									
172.95 (128.97)	17076 (75.96)	3.80 (6.12)	2100	3.9	0.452 (0.275)	15.51 (3.06)	220 (104)	81 (27)	28.63 (96.95)
9th Gear									
175.71 (131.03)	15038 (66.89)	4.38 (7.05)	2100	3.1	0.447 (0.272)	15.71 (3.10)	220 (104)	79 (26)	28.75 (97.36)
10th Gear									
179.37 (133.75)	13215 (58.78)	5.09 (8.19)	2100	2.6	0.437 (0.266)	16.05 (3.16)	220 (104)	70 (21)	28.76 (97.39)
11th Gear									
178.83 (133.35)	11368 (50.57)	5.90 (9.50)	2099	2.4	0.439 (0.267)	15.99 (3.15)	220 (104)	69 (20)	28.76 (97.39)
12th Gear									
177.74 (132.54)	9786 (43.53)	6.81 (10.96)	2099	1.9	0.441 (0.268)	15.92 (3.14)	220 (104)	72 (22)	28.77 (97.43)
13th Gear									
176.32 (131.48)	8382 (37.28)	7.89 (12.70)	2100	1.6	0.442 (0.269)	15.86 (3.12)	220 (104)	74 (24)	28.77 (97.43)
14th Gear									
173.40 (129.30)	7185 (31.96)	9.05 (14.56)	2100	1.3	0.450 (0.274)	15.59 (3.07)	220 (104)	77 (25)	28.76 (97.39)

TRACTOR SOUND LEVEL WITH CAB

	Front Wheel Drive Engaged dB(A)	Disengaged dB(A)
At no load in 9th gear	66.2	66.1
Transport speed - no load - 21st gear		69.6
Bystander in 21st gear		83.5

Horizontal distance of drawbar hitch point behind rear wheel axis - 47.4"(1203 mm)

TIRES AND WEIGHT

Rear Tires - No., size, ply & psi(kPa)
Front Tires - No., size, ply & psi(kPa)
Height of Drawbar
Static Weight with operator - Rear
- Front
- Total

Tested Without Ballast

Four 480/80R46;***;12(85)
Two 420/90R30;***;15(105)
18.5 in (470 mm)
14950 lb (6781 kg)
7910 lb (3588 kg)
22860 lb(10369 kg)

reverse 1.37 (2.20), 1.83 (2.94), 2.42 (3.90), 3.21 (5.16), 3.67 (5.90), 4.89 (7.87), 6.49 (10.45), 8.59 (13.82), 11.51 (18.54), 15.37 (24.73), 18.64 (30.00) electronically limited **Clutch** wet multiple disc hydraulically actuated by foot pedal **Brakes** wet multiple disc hydraulically operated by two foot pedals that can be locked together **Steering** hydrostatic **Power take-off** 540 rpm at 1958 engine rpm or 1000 rpm at 1950 engine rpm **Unladen tractor mass** 22685 lb (10290 kg)

REPAIRS AND ADJUSTMENTS: No repairs or adjustments.

NOTE 1: The manufacturer declares that the average time between active regenerations is 40 hours, while operated in Auto Filter Cleaning Mode, at rated speed, full load, under steady state conditions. A 4% power increase was observed during the active regeneration.

REMARKS: All test results were determined from observed data obtained in accordance with official OECD, SAE and Nebraska test procedures. This tractor fell 1.2% short of meeting the manufacturer's remote hydraulic flow claim of 59 GPM (223.3 l/min) with the 85 cc pump. The performance figures on this summary were taken from a test conducted under the OECD Code 2 test procedure.

REPORT REISSUED. Supplemental sales permit for John Deere 7R 230 Diesel, January, 2021.

We, the undersigned, certify that this is a true and correct report of official Tractor Test No. **2090A**, Nebraska Summary 939A, January 14, 2021.

Roger M. Hoy
Director

M.F. Kocher
P.J. Jasa
J.D. Luck
Board of Tractor Test Engineers

DRAWBAR PERFORMANCE
UNBALLASTED - FRONT DRIVE ENGAGED - AUTO MODE
(Loads based on 2100 engine rpm manual mode performance runs)
DRAWBAR POWER AT SELECTED TRAVEL SPEEDS

Power Hp (kW)	Drawbar pull lbs (kN)	Speed mph (km/h)	Crank- shaft speed rpm	Slip %	Fuel Consumption lb/hp.hr (kg/kW.h)	Hp.hr/gal (kW.h/l)	Temp. °F(°C) cool- ing med	Air dry bulb	Barom. inch Hg (kPa)
3.5 mph (5.6 km/h)									
171.14 (127.62)	19707 (87.66)	3.26 (5.25)	1616	6.6	0.434 (0.264)	16.18 (3.19)	219 (104)	83 (28)	28.61 (96.88)
4.0 mph (6.4 km/h)									
173.22 (129.17)	17013 (75.68)	3.82 (6.15)	1599	4.0	0.422 (0.257)	16.62 (3.27)	219 (104)	82 (28)	28.62 (96.92)
4.5 mph (7.2 km/h)									
175.39 (130.78)	15176 (67.50)	4.33 (6.97)	1558	3.3	0.419 (0.255)	16.76 (3.30)	219 (104)	80 (26)	28.75 (97.36)
5.2 mph (8.4 km/h)									
178.61 (133.19)	13158 (58.53)	5.09 (8.19)	1580	2.6	0.417 (0.254)	16.81 (3.31)	219 (104)	71 (22)	28.76 (97.39)
6.0 mph (9.6 km/h)									
178.38 (133.02)	11458 (50.97)	5.84 (9.40)	1563	2.2	0.418 (0.254)	16.80 (3.31)	219 (104)	70 (21)	28.75 (97.36)
6.9 mph (11.2 km/h)									
177.73 (132.53)	9761 (43.42)	6.83 (10.99)	1592	1.9	0.418 (0.254)	16.78 (3.31)	219 (104)	72 (22)	28.77 (97.43)
8.1 mph (13.0 km/h)									
176.92 (131.93)	8344 (37.12)	7.95 (12.79)	1601	1.6	0.419 (0.255)	16.74 (3.30)	219 (104)	76 (25)	28.76 (97.39)
9.2 mph (14.8 km/h)									
173.60 (129.45)	7174 (31.91)	9.08 (14.60)	1570	1.3	0.428 (0.260)	16.39 (3.23)	219 (104)	78 (25)	28.76 (97.39)

DRAWBAR PERFORMANCE
UNBALLASTED - FRONT DRIVE ENGAGED - 1700 ENGINE RPM
MAXIMUM POWER IN SELECTED GEARS

Power Hp (kW)	Drawbar pull lbs (kN)	Speed mph (km/h)	Crank- shaft speed rpm	Slip %	Fuel Consumption lb/hp.hr (kg/kW.h)	Fuel Consumption Hp.hr/gal (kW.h/l)	Temp. °F(°C) cool- ing med	Air dry bulb	Barom. inch Hg (kPa)
6th Gear									
150.46 (112.20)	20867 (92.82)	2.71 (4.35)	2151	13.9	0.498 (0.303)	14.08 (2.77)	219 (104)	83 (29)	28.61 (96.92)
7th Gear									
170.61 (127.22)	20044 (89.16)	3.20 (5.14)	2100	6.9	0.461 (0.280)	15.22 (3.00)	220 (104)	82 (28)	28.61 (96.92)
8th Gear									
184.23 (137.38)	19400 (86.29)	3.57 (5.74)	2028	6.7	0.459 (0.279)	15.29 (3.01)	221 (105)	85 (30)	28.59 (96.82)
9th Gear									
192.84 (143.80)	18262 (81.23)	3.96 (6.37)	1945	5.4	0.448 (0.272)	15.68 (3.09)	221 (105)	86 (30)	28.59 (96.82)
10th Gear									
195.34 (145.67)	17034 (75.77)	4.30 (6.92)	1812	4.6	0.431 (0.262)	16.29 (3.21)	221 (105)	86 (30)	28.59 (96.82)
11th Gear									
203.27 (151.57)	16161 (71.89)	4.72 (7.60)	1700	3.5	0.425 (0.259)	16.51 (3.25)	221 (105)	78 (26)	28.64 (96.99)
12th Gear									
204.01 (152.13)	14003 (62.29)	5.46 (8.79)	1700	2.7	0.423 (0.257)	16.58 (3.27)	220 (104)	79 (26)	28.63 (96.95)
13th Gear									
203.06 (151.42)	12009 (53.42)	6.34 (10.20)	1700	2.4	0.423 (0.257)	16.61 (3.27)	220 (104)	80 (27)	28.64 (96.99)
14th Gear									
203.42 (151.69)	10481 (46.62)	7.28 (11.72)	1700	1.9	0.425 (0.258)	16.53 (3.26)	220 (104)	80 (27)	28.63 (96.95)
15th Gear									
202.06 (150.68)	8982 (39.95)	8.44 (13.57)	1700	1.7	0.428 (0.260)	16.39 (3.23)	220 (104)	81 (27)	28.63 (96.95)

HYDRAULIC PERFORMANCE

CATEGORY: III

Quick Attach: Yes

OECD Static test

		<u>lift cylinders</u>
Maximum force exerted through whole range:	15862 lbs (70.6 kN)	(2x100 mm)
	18302 lbs (81.4 kN)	(1x100 mm & 1x115 mm)
	<u>63 cc pump</u>	<u>85 cc pump</u>
i) Sustained pressure at compensator cutoff:	2955 psi (204 bar)	2931 psi (202 bar)
	<u>three outlet sets combined</u>	
ii) Pump delivery rate at minimum pressure and rated engine speed:	44.4 GPM (168.1 l/min)	58.3 GPM (220.7 l/min)
iii) Pump delivery rate at maximum hydraulic power:	43.3 GPM (164.0 l/min)	57.5 GPM (217.6 l/min)
Delivery pressure:	2761 psi (190 bar)	2571 psi (177 bar)
Power:	69.8 HP (52.0 kW)	86.2 HP (64.3 kW)
	<u>single outlet set</u>	
ii) Pump delivery rate at minimum pressure and rated engine speed:	36.1 GPM (136.5 l/min)	36.4 GPM (137.9 l/min)
iii) Pump delivery rate at maximum hydraulic power:	35.5 GPM (134.5 l/min)	35.4 GPM (134.0 l/min)
Delivery pressure:	2298 psi (158 bar)	2244 psi (155 bar)
Power:	47.6 HP (35.5 kW)	46.4 HP (34.6 kW)

HITCH DIMENSIONS AS TESTED—NO LOAD

	inch	mm
A	28.0	710
B	20.5	520
C	22.9	581
D	18.9	480
E	7.3	185
F	14.4	365
G	38.8	985
H	3.5	90
I	22.4	570
J	24.4	620
K	29.3	745
L	52.0	1321
*L'	56.0	1423
M	28.0	712
N	43.4	1102
O	9.0	230
P	51.9	1319
Q	39.4	1001
R	44.9	1140

*L' to Quick Attach ends

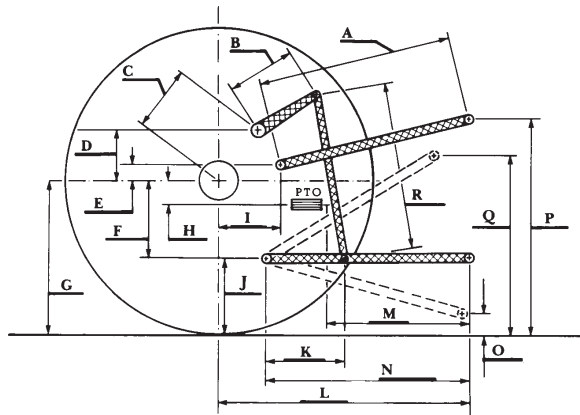

RECOMMENDED CITATION FORMAT:

NTTL.(2021). Nebraska OECD tractor test 2090A for John Deere 7R 230 e23 Diesel. Lincoln, NE:Nebraska Tractor Test Laboratory. Retrieved from <http://tractortestlab.unl.edu>



JOHN DEERE 7R 230 e23 DIESEL
 Institute of Agriculture and Natural Resources
 University of Nebraska–Lincoln