

# NEBRASKA OECD TRACTOR TEST 2166 - SUMMARY 1047

## CHALLENGER MT845E DIESEL

### 16 SPEED

#### POWER TAKE-OFF PERFORMANCE

Power HP (kW)	Crank shaft speed rpm	Diesel Consumption		D.E.F. Consumption		Mean Atmospheric Conditions
		Gal/hr (l/h)	lb/hp.hr (kg/kW.h)	Hp.hr/gal (kW.h/l)	Gal/hr (l/h)	
<b>MAXIMUM POWER AND FUEL CONSUMPTION</b>						
<b>Rated Engine Speed—(PTO speed—1061 rpm)</b>						
369.66 (275.66)	2100	23.77 (89.99)	0.450 (0.274)	15.55 (3.06)	0.66 (2.48)	
<b>Maximum Power (1 hour)</b>						
421.56 (314.36)	1979	24.88 (94.18)	0.413 (0.251)	16.94 (3.34)	0.70 (2.64)	
<b>Standard Power Take-off Speed (1000 rpm)</b>						
421.56 (314.36)	1979	24.88 (94.18)	0.413 (0.251)	16.94 (3.34)	0.70 (2.64)	
<b>VARYING POWER AND FUEL CONSUMPTION</b>						
369.66 (275.66)	2100	23.77 (89.99)	0.450 (0.274)	15.55 (3.06)	0.66 (2.48)	Air temperature
319.88 (238.53)	2137	21.94 (83.06)	0.480 (0.292)	14.58 (2.87)	0.55 (2.07)	73°F (23°C)
242.61 (180.91)	2161	18.67 (70.67)	0.539 (0.328)	13.00 (2.56)	0.39 (1.48)	Relative humidity
162.51 (121.18)	2169	15.31 (57.95)	0.660 (0.401)	10.61 (2.09)	0.25 (0.95)	50%
81.67 (60.90)	2175	11.81 (44.70)	1.012 (0.616)	6.92 (1.36)	0.09 (0.34)	Barometer
1.65 (1.23)	2181	8.36 (31.63)	35.397 (21.531)	0.20 (0.04)	0.05 (0.18)	28.83" Hg (97.65 kPa)

Maximum torque - 1464 lb.-ft. (1984 Nm) at 1100 rpm  
 Maximum torque rise - 58.3%  
 Torque rise at 1680 engine rpm - 38%  
 Power increase at 1979 engine rpm - 14.0%

#### DRAWBAR PERFORMANCE (UNBALLASTED)

##### FUEL CONSUMPTION CHARACTERISTICS

Power Hp (kW)	Drawbar pull lbs (kN)	Speed mph (km/h)	Crank- shaft speed rpm	Slip %	Fuel Consumption lb/hp.hr (kg/kW.h)	D.E.F. Consumption Hp.hr/gal (kW.h/l)	Temp. °F(°C) cool- ing med	Air dry bulb	Barom. inch Hg (kPa)	
<b>Power at Rated Engine Speed—6th Gear</b>										
324.23 (241.85)	27190 (120.94)	4.48 (7.20)	2100	2.2	0.513 (0.312)	13.65 (2.69)	0.021 (0.013)	162 (72)	64 (18)	29.06 (98.41)
<b>75% of Pull at Rated Engine Speed—6th Gear</b>										
252.89 (188.58)	20405 (90.77)	4.65 (7.48)	2159	1.2	0.568 (0.346)	12.32 (2.43)	0.016 (0.009)	163 (73)	73 (23)	29.07 (98.44)
<b>50% of Pull at Rated Engine Speed—6th Gear</b>										
170.30 (126.99)	13607 (60.53)	4.69 (7.55)	2166	0.5	0.691 (0.420)	10.13 (2.00)	0.019 (0.012)	161 (72)	74 (23)	29.05 (98.37)
<b>75% of Pull at Reduced Engine Speed—10th Gear</b>										
252.68 (188.42)	20504 (91.21)	4.62 (7.44)	1336	1.2	0.421 (0.256)	16.65 (3.28)	0.026 (0.016)	166 (74)	73 (23)	29.03 (98.31)
<b>50% of Pull at Reduced Engine Speed—10th Gear</b>										
170.13 (126.86)	13630 (60.63)	4.68 (7.53)	1344	0.5	0.471 (0.287)	14.86 (2.93)	0.024 (0.015)	164 (73)	74 (24)	29.03 (98.31)

**Location of tests:** Nebraska Tractor Test Laboratory, University of Nebraska, Lincoln, Nebraska 68583-0832

**Dates of tests:** November 2 - 7, 2016

**Manufacturer:** AGCO Corporation, 4205 River Green Parkway, Duluth Ga 30096

**CONSUMABLE Fluids, OIL and TIME: Fuel** No. 2 Diesel **Specific gravity converted to 60°/60°F (15°/15°C)** 0.8408 **Fuel weight** 7.001 lbs/gal (0.839 kg/l) **Diesel Exhaust Fluid (DEF)** 32% aqueous urea solution **DEF weight** 9.071 lbs/gal (1.087 kg/l) **Oil** SAE 10W-40 **API service classification** CJ-4 **Transmission and hydraulic lubricant** AGCO Permatran 821 XL fluid **Total time engine was operated:** 17.5 hours

**ENGINE: Make** AGCO **Power Diesel Type** twelve cylinder vee with 4 turbochargers, two stage air to water aftercooler and D.E.F. (diesel exhaust fluid) exhaust treatment **Serial No.\*** C54852\* **Crankshaft** lengthwise **Rated engine speed** 2100 **Bore and stroke** 4.370" x 5.709" (111.0 mm x 145.0 mm) **Compression ratio** 16.7 to 1 **Displacement** 1026 cu in (16838 ml) **Starting system** 12 volt **Lubrication** pressure **Air cleaner** two paper elements and aspirator **Oil filter** one full flow cartridge **Oil cooler** engine coolant heat exchanger for crankcase oil, radiator for hydraulic and transmission oil **Fuel filter** two paper elements and water separator **Fuel cooler** radiator for returned fuel **Exhaust** DOC (diesel oxidation catalyst) and SCR (selective catalyst reduction) integrated within a vertical muffler **Cooling medium temperature control** 2 thermostats

**ENGINE OPERATING PARAMETERS: Fuel rate:** 152.0- 168.0 lb/h (68.9 - 76.2 kg/h) **High idle:** 2160-2200 rpm **Turbo boost:** nominal 24.7 - 26.8 psi (170 - 185 kPa) as measured 25.8 psi (178 kPa)

**CHASSIS: Type** tracklayer-rubber tracked **Serial No.\*** AGCO845EGNHG1017\* **Track width** 100.0" (2540 mm) to 120.0" (3048 mm) **Length of track on ground** 124.3" (3157 mm) **Hydraulic control system** direct engine drive **Transmission** selective gear fixed ratio with full range operator controlled power shift **Nominal travel speeds mph (km/h)** first 1.67 (2.69) second 2.13 (3.43) third 2.68 (4.31) fourth 3.41 (5.48) fifth 4.06 (6.54) sixth 4.58 (7.37) seventh 5.16 (8.31) eighth 5.80 (9.34) ninth 6.53 (10.51) tenth 7.34 (11.82) eleventh 8.29 (13.34) twelfth 9.33 (15.02) thirteenth 11.10 (17.87) fourteenth 14.11 (22.71) fifteenth 17.86 (28.75) sixteenth 24.86 (40.00) at 2270 rpm, reverse 1.34 (2.16), 3.24 (5.22), 3.66 (5.89), 8.89 (14.30)

**DRAWBAR PERFORMANCE**  
**UNBALLASTED AT 2100 ENGINE RPM**  
**MAXIMUM POWER IN SELECTED GEARS**

Power Hp (kW)	Drawbar pull lbs (kN)	Speed mph (km/h)	Crank- shaft speed rpm	Slip %	Fuel Consumption lb/hp.hr (kg/kW.h)	Hp.hr/gal (kW.h/l)	D.E.F Consumption lb/hp.hr (kg/kW.h)	Temp. °F(°C) cool- ing med	Air dry bulb	Barom. inch Hg (kPa)
					<b>3rd Gear</b>					
282.47 (210.64)	45177 (200.96)	2.35 (3.77)	2099	12.8	0.586 (0.357)	11.94 (2.35)	0.022 (0.013)	163 (73)	59 (15)	29.11 (98.58)
					<b>4th Gear</b>					
304.93 (227.38)	35132 (156.27)	3.26 (5.24)	2097	4.5	0.545 (0.332)	12.84 (2.53)	0.021 (0.013)	163 (73)	61 (16)	29.13 (98.65)
					<b>5th Gear</b>					
320.44 (238.95)	30544 (135.87)	3.94 (6.33)	2100	3.2	0.519 (0.316)	13.48 (2.66)	0.021 (0.012)	165 (74)	66 (19)	29.11 (98.58)
					<b>6th Gear</b>					
324.33 (241.85)	27190 (120.94)	4.48 (7.20)	2100	2.2	0.513 (0.312)	13.65 (2.69)	0.021 (0.013)	162 (72)	64 (18)	29.06 (98.41)
					<b>7th Gear</b>					
319.45 (238.21)	23586 (104.91)	5.08 (8.18)	2100	1.5	0.519 (0.316)	13.48 (2.66)	0.020 (0.012)	162 (72)	62 (17)	29.07 (98.44)
					<b>8th Gear</b>					
321.01 (239.38)	20979 (93.32)	5.74 (9.23)	2100	1.3	0.519 (0.316)	13.49 (2.66)	0.020 (0.012)	163 (73)	66 (19)	29.06 (98.41)
					<b>9th Gear</b>					
312.46 (233.00)	18101 (80.52)	6.48 (10.42)	2100	0.9	0.534 (0.325)	13.11 (2.58)	0.022 (0.013)	164 (73)	68 (20)	29.08 (98.48)
					<b>10th Gear</b>					
313.58 (233.84)	16109 (71.66)	7.30 (11.75)	2100	0.7	0.534 (0.325)	13.12 (2.58)	0.021 (0.013)	165 (74)	71 (22)	29.07 (98.44)
					<b>11th Gear</b>					
300.53 (224.11)	13663 (60.78)	8.25 (13.28)	2100	0.5	0.554 (0.337)	12.64 (2.49)	0.023 (0.014)	165 (74)	73 (23)	29.03 (98.31)

**Clutch** wet multiple disc hydraulically actuated by foot pedal **Brakes** wet multiple disc hydraulically actuated by foot pedal **Steering** electro-hydraulic differential steering controlled by steering wheel **Power take-off** 1000 rpm at 1980 engine rpm **Unladen tractor mass** 43850 lb (19890 kg)

**REPAIRS AND ADJUSTMENTS:** No repairs or adjustments.

**REMARKS:** All test results were determined from observed data obtained in accordance with official OECD, SAE and Nebraska test procedures. The performance figures on this Summary were taken from a test conducted under the OECD Code 2 test procedure.

We, the undersigned, certify that this is a true and correct report of official Tractor Test No. **2166**, Nebraska Summary 1047, January 9, 2017.

Roger M. Hoy  
 Director

M.F. Kocher  
 P.J. Jasa  
 S.K. Pitla  
 Board of Tractor Test Engineers

<b>TRACTOR SOUND LEVEL WITH CAB</b>	<b>dB(A)</b>
At no load in 6th gear	73.8
Bystander in 15th gear	89.8

**TRACKS AND WEIGHT**  
 Track width  
 Height of Drawbar  
 Static Weight with operator

**Tested Without Ballast**  
 36.0 in (915 mm)  
 21.0 in (535 mm)  
 44025 lb (19969 kg)

**DRAWBAR PERFORMANCE**  
**UNBALLASTED AT 1980 ENGINE RPM**  
**MAXIMUM POWER IN SELECTED GEARS**

Power Hp (kW)	Drawbar pull lbs (kN)	Speed mph (km/h)	Crank- shaft speed rpm	Slip %	Fuel Consumption lb/hp.hr (kg/kW.h)	Hp.hr/gal (kW.h/l)	D.E.F Consumption lb/hp.hr (kg/kW.h)	Temp. °F(°C) cool- ing med	Air dry bulb	Barom. inch Hg (kPa)
					3rd Gear					
288.31 (214.99)	45821 (203.82)	2.36 (3.80)	2093	11.9	0.579 (0.352)	12.10 (2.38)	0.022 (0.013)	162 (72)	57 (14)	29.11 (98.58)
					4th Gear					
326.84 (243.72)	41341 (183.89)	2.97 (4.77)	1982	8.0	0.518 (0.315)	13.51 (2.66)	0.019 (0.012)	165 (74)	60 (16)	29.12 (98.61)
					5th Gear					
357.67 (266.71)	37452 (166.59)	3.59 (5.77)	1965	5.8	0.483 (0.294)	14.49 (2.86)	0.020 (0.012)	167 (75)	67 (19)	29.11 (98.58)
					6th Gear					
369.72 (275.70)	33404 (148.59)	4.15 (6.68)	1976	3.6	0.472 (0.287)	14.82 (2.92)	0.018 (0.011)	163 (73)	53 (12)	29.14 (98.68)
					7th Gear					
367.42 (273.99)	29053 (129.23)	4.74 (7.63)	1980	2.5	0.476 (0.290)	14.71 (2.90)	0.019 (0.012)	163 (73)	49 (9)	29.12 (98.61)
					8th Gear					
370.56 (276.32)	25862 (115.04)	5.37 (8.64)	1980	1.9	0.472 (0.287)	14.84 (2.92)	0.019 (0.011)	164 (73)	51 (11)	29.12 (98.61)
					9th Gear					
365.62 (272.64)	22639 (100.70)	6.06 (9.74)	1977	1.5	0.478 (0.290)	14.66 (2.89)	0.020 (0.012)	167 (75)	67 (20)	29.12 (98.61)
					10th Gear					
366.22 (273.09)	20036 (89.12)	6.86 (11.03)	1979	0.9	0.478 (0.291)	14.66 (2.89)	0.020 (0.012)	167 (75)	68 (20)	29.10 (98.54)
					11th Gear					
354.07 (264.03)	17137 (76.23)	7.75 (12.47)	1978	0.6	0.493 (0.300)	14.20 (2.80)	0.021 (0.013)	167 (75)	68 (20)	29.09 (98.51)
					12th Gear					
352.16 (262.60)	15109 (67.21)	8.74 (14.07)	1979	0.5	0.494 (0.301)	14.17 (2.79)	0.021 (0.013)	168 (75)	69 (20)	29.11 (98.58)

## HYDRAULIC PERFORMANCE

CATEGORY: IVN

Quick Attach: yes

OECD Static test

Maximum force exerted through whole range: 20936 lbs (93.1 kN)

	<b>Standard pump</b> 3 inlets - 3 outlets	<b>High flow pump</b> 3 inlets - 3 outlets
i) Sustained pressure at compensator cutoff:	2865 psi (198 bar)	2888 psi (199 bar)
ii) Pump delivery rate at minimum pressure and rated engine speed:	58.3 GPM (220.8 l/min)	86.6 GPM (327.7 l/min)
iii) Pump delivery rate at maximum hydraulic power:	55.1 GPM (208.5 l/min)	82.8 GPM (313.6 l/min)
Delivery pressure:	2826 psi (195 bar)	2769 psi (191 bar)
Power:	90.8 HP (67.7 kW)	133.8 HP (99.8 kW)
	<b>1 inlet - 1 outlet</b>	<b>1 inlet - 1 outlet</b>
i) Sustained pressure at compensator cutoff:	2875 psi (198 bar)	2896 psi (200 bar)
ii) Pump delivery rate at minimum pressure and rated engine speed:	38.3 GPM (145.2 l/min)	40.0 GPM (151.4 l/min)
iii) Pump delivery rate at maximum hydraulic power:	37.4 GPM (141.6 l/min)	37.2 GPM (140.9 l/min)
Delivery pressure:	2297 psi (158 bar)	2404 psi (166 bar)
Power:	50.1 HP (37.4 kW)	52.2 HP (38.9 kW)

## HITCH DIMENSIONS AS TESTED - NO LOAD

	inch	mm
A	30.2	768
B	21.7	550
C	41.4	1051
D	39.4	1000
E	12.4	315
F	11.8	300
G	35.0	890
H	0.4	10
I	23.0	585
J	23.2	590
K	29.0	737
L	53.9	1369
*L'	60.4	1534
M	26.6	676
N	36.6	929
O	9.0	230
P	50.2	1275
Q	46.5	1181
R	55.9	1421

\*L' to Quick Attach ends

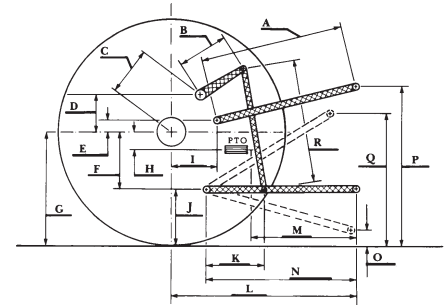

**Challenger MT845E Diesel**

Institute of Agriculture and Natural Resources  
University of Nebraska-Lincoln