

# NEBRASKA OECD TRACTOR TEST 2163 - SUMMARY 1044

## CASE IH STEIGER 580 QUADTRAC DIESEL

### 16 SPEED

#### POWER TAKE-OFF PERFORMANCE

Power HP (kW)	Crank shaft speed rpm	Diesel Consumption		D.E.F. Consumption		Mean Atmospheric Conditions
		Gal/hr (l/h)	lb/hp.hr (kg/kW.h)	Hp.hr/gal (kW.h/l)	Gal/hr (l/h)	
<b>MAXIMUM POWER AND FUEL CONSUMPTION</b>						
<b>Rated Engine Speed—(PTO speed—1160 rpm)</b>						
475.26 (354.40)	2101	26.15 (99.01)	0.386 (0.235)	18.17 (3.58)	2.13 (8.05)	
<b>Maximum Power (1 hour)</b>						
533.70 (397.98)	1900	27.97 (105.87)	0.367 (0.223)	19.08 (3.76)	2.34 (8.86)	
<b>Standard Power Take-off Speed (1000 rpm)</b>						
532.55 (397.12)	1811	27.42 (103.81)	0.361 (0.220)	19.42 (3.83)	2.16 (8.17)	

#### VARYING POWER AND FUEL CONSUMPTION

475.26 (354.40)	2101	26.15 (99.01)	0.386 (0.235)	18.17 (3.58)	2.13 (8.05)	Air temperature
412.86 (307.87)	2148	23.65 (89.51)	0.401 (0.244)	17.46 (3.44)	1.91 (7.24)	82°F (28°C)
311.69 (232.43)	2160	18.78 (71.09)	0.422 (0.257)	16.60 (3.27)	1.49 (5.64)	Relative humidity
208.85 (155.74)	2170	14.15 (53.55)	0.475 (0.289)	14.76 (2.91)	1.11 (4.18)	57%
104.72 (78.09)	2180	9.64 (36.51)	0.645 (0.393)	10.86 (2.14)	0.62 (2.36)	Barometer
1.43 (1.07)	2190	5.37 (20.33)	26.237 (15.960)	0.27 (0.05)	0.23 (0.88)	28.67" Hg (97.10 kPa)

Maximum torque - 1755 lb-ft (2379 Nm) at 1400 rpm

Maximum torque rise - 47.7%

Torque rise at 1681 engine rpm - 37%

Power increase at 1900 engine rpm - 12.3%

#### DRAWBAR PERFORMANCE FUEL CONSUMPTION CHARACTERISTICS

Power Hp (kW)	Drawbar pull lbs (kN)	Speed mph (km/h)	Crank- shaft speed rpm	Slip %	Fuel Consumption		D.E.F. Consumption	Temp. °F (°C)		Barom. inch Hg (kPa)
					lb/hp.hr (kg/kW.h)	Hp.hr/gal (kW.h/l)	lb/hp.hr (kg/kW.h)	cool- ing med	Air dry bulb	
<b>Power at Rated Engine Speed—5th Gear</b>										
460.87 (343.67)	31824 (141.56)	5.43 (8.74)	2099	2.7	0.432 (0.263)	16.21 (3.19)	0.048 (0.029)	201 (94)	78 (26)	28.69 (97.16)
<b>75% of Pull at Rated Engine Speed—5th Gear</b>										
356.23 (265.64)	23863 (106.15)	5.60 (9.01)	2139	1.6	0.452 (0.275)	15.51 (3.05)	0.044 (0.027)	199 (93)	85 (30)	28.70 (97.19)
<b>50% of Pull at Rated Engine Speed—5th Gear</b>										
240.32 (179.21)	15920 (70.82)	5.66 (9.11)	2148	0.9	0.497 (0.303)	14.09 (2.78)	0.050 (0.030)	192 (98)	85 (30)	28.68 (97.12)
<b>75% of Pull at Reduced Engine Speed—9th Gear</b>										
355.27 (264.92)	23654 (105.22)	5.63 (9.06)	1479	1.6	0.399 (0.243)	17.55 (3.46)	0.039 (0.024)	199 (93)	86 (30)	28.70 (97.19)
<b>50% of Pull at Reduced Engine Speed—9th Gear</b>										
240.56 (179.39)	15875 (70.61)	5.68 (9.14)	1482	0.9	0.425 (0.258)	16.50 (3.25)	0.042 (0.025)	185 (85)	86 (30)	28.69 (97.16)

**Location of tests:** Nebraska Tractor Test Laboratory, University of Nebraska, Lincoln Nebraska 68583-0832

**Dates of tests:** September 19 - 28, 2016

**Manufacturer:** Case Corporation, 700 State Street Racine, Wi. 53404 USA.

**CONSUMABLE Fluids, OIL and TIME: Fuel** No. 2 Diesel **Specific gravity converted to 60°/60°F (15°/15°C)** 0.8418 **Fuel weight** 7.009 lbs/gal (0.840 kg/l) **Diesel Exhaust Fluid (DEF)** 32% aqueous urea solution **DEF weight** 9.071 lbs/gal (1.087 kg/l) **Oil SAE 15W40 API service classification CJ-4 Transmission lubricant Akcela Hy-Tran Ultraction fluid Hydraulic and axle lubricant Akcela Hy-Tran Ultraction fluid Total time engine was operated:** 23.0 hours

**ENGINE: Make** F.P.T. Diesel **Type** six cylinder vertical with two turbochargers, two stage air to water intercooler and D.E.F. (diesel exhaust fluid) exhaust treatment **Serial No.** 0000083790 **Crankshaft** lengthwise **Rated engine speed** 2100 **Bore and stroke** 5.315" x 5.906" (135.0 mm x 150.0 mm) **Compression ratio** 15.5 to 1 **Displacement** 786 cu in (12880 ml) **Starting system** 24 volt **Lubrication** pressure **Air cleaner** two paper elements and aspirator **Oil filter** one full flow cartridge **Oil cooler** engine coolant heat exchanger for crankcase oil, separate radiators for hydraulic and transmission oil **Fuel filter** two paper elements **Fuel cooler** radiator for pump return fuel **Exhaust** DOC (diesel oxidation catalyst) and SCR (selective catalyst reduction) within a vertical muffler **Cooling medium temperature control** thermostat and variable speed fan

**ENGINE OPERATING PARAMETERS: Fuel rate:** 535 engine hp: 180.1 - 191.1 lb/h (81.7 - 86.7 kg/h) 580 engine hp: 193.3 - 205.0 lb/h (87.7 - 93.0 kg/h) **High idle:** 2175 - 2225 rpm **Turbo boost:** nominal 38.4 - 41.3 psi (265 - 285 kPa) as measured 40.2 psi (277 kPa)

**CHASSIS: Type** 4WD with rubber tracks **Serial No.** \*ZGF309069\* **Track width** rear 88.0" (2235 mm) front 88.0" (2235 mm) **Trackbase** 154.0" (3912 mm) **Length of track on ground** 29.4" (748 mm) **Hydraulic control system** direct engine drive **Transmission** selective gear fixed ratio with full range operator controlled powershift **Nominal travel speeds mph (km/h)** first 2.77 (4.45) second 3.33 (5.36) third 4.03 (6.48) fourth 4.85 (7.80) fifth 5.57 (8.96) sixth 6.11 (9.84) seventh 6.70 (10.79) eighth 7.37 (11.86) ninth 8.10 (13.03) tenth 8.90 (14.32) eleventh 9.76 (15.70) twelfth 10.72 (17.25) thirteenth 12.31 (19.81) fourteenth 14.83 (23.86) fifteenth 17.90 (28.81) sixteenth 21.01 (33.81) reverse 4.21 (6.77), 9.30 (14.97)

**DRAWBAR PERFORMANCE AT 2100 ENGINE RPM  
MAXIMUM POWER IN SELECTED GEARS**

Power Hp (kW)	Drawbar pull lbs (kN)	Speed mph (km/h)	Crank- shaft speed rpm	Slip %	Fuel Consumption lb/hp.hr (kg/kW.h)	Hp.hr/gal (kW.h/l)	D.E.F. Consumption lb/hp.hr (kg/kW.h)	Temp.°F (°C) cool- ing med	Air dry bulb	Barom. inch Hg (kPa)
					<b>2nd Gear</b>					
410.55 (306.15)	52714 (234.48)	2.92 (4.70)	2107	13.1	0.482 (0.293)	14.56 (2.87)	0.051 (0.031)	199 (93)	79 (26)	28.61 (96.88)
					<b>3rd Gear</b>					
441.07 (328.90)	44271 (196.93)	3.74 (6.01)	2099	7.4	0.448 (0.273)	15.64 (3.08)	0.049 (0.030)	201 (94)	81 (27)	28.62 (96.92)
					<b>4th Gear</b>					
455.96 (340.01)	36514 (162.42)	4.69 (7.54)	2099	3.7	0.437 (0.266)	16.04 (3.16)	0.049 (0.030)	200 (93)	79 (26)	28.70 (97.19)
					<b>5th Gear</b>					
460.87 (343.67)	31824 (141.56)	5.43 (8.74)	2099	2.7	0.432 (0.263)	16.21 (3.19)	0.048 (0.029)	201 (94)	78 (26)	28.69 (97.16)
					<b>6th Gear</b>					
461.04 (343.80)	28828 (128.23)	6.00 (9.66)	2099	2.2	0.431 (0.262)	16.28 (3.21)	0.047 (0.029)	200 (93)	80 (27)	28.69 (97.16)
					<b>7th Gear</b>					
459.03 (342.30)	26066 (115.95)	6.60 (10.62)	2100	1.8	0.434 (0.264)	16.17 (3.18)	0.047 (0.029)	201 (94)	81 (27)	28.70 (97.19)
					<b>8th Gear</b>					
458.82 (342.14)	23651 (105.20)	7.28 (11.71)	2099	1.5	0.434 (0.264)	16.17 (3.18)	0.048 (0.029)	200 (93)	83 (28)	28.68 (97.12)
					<b>9th Gear</b>					
455.36 (339.56)	21292 (94.71)	8.02 (12.91)	2100	1.3	0.437 (0.266)	16.02 (3.16)	0.048 (0.029)	202 (94)	83 (28)	28.70 (97.19)

**Clutch** multiple wet disc electro-hydraulically operated by foot pedal **Brakes** single wet disc hydraulically actuated by foot pedal **Steering** hydrostatic and articulated **Power take-off** 1000 rpm at 1811 engine rpm **Unladen tractor mass** 60145 lb (27281 kg)

**REPAIRS AND ADJUSTMENTS:** No repairs or adjustments.

**NOTE 1:** This tractor has a driveline protection system that limits the maximum engine torque in gears 1 through 4.

**NOTE 2:** The performance figures on this report are the result of replacing the electronic engine control module of the Case IH 620 Quadtrac with the Case IH 580 Quadtrac module.

**REMARKS:** All test results were determined from observed data obtained in accordance with official OECD, SAE and Nebraska test procedures. The performance figures on this Summary were taken from a test conducted under the OECD Code 2 test procedure.

We, the undersigned, certify that this is a true and correct report of official Tractor Test No. **2163**, Nebraska Summary 1044, December 12, 2016.

Roger M. Hoy  
Director

M.F. Kocher  
P.J. Jasa  
J.D. Luck  
Board of Tractor Test Engineers

TRACTOR SOUND LEVEL WITH CAB	dB(A)
At no load in 4th gear	73.6
Bystander in 16th Gear	87.9

**TRACKS AND WEIGHT**

**Rear tracks** - no & size  
**Front tracks** - no & size  
**Height of drawbar**  
**Static weight with operator- Rear**  
- Front  
- Total

**Tested Without Ballast**

2 x 30.0 in (762 mm)  
2 x 30.0 in (762 mm)  
20.5 in (520 mm)  
24820 lb (11258 kg)  
35500 lb (16103 kg)  
60320 lb (27361 kg)

**DRAWBAR PERFORMANCE AT 1900 ENGINE RPM  
MAXIMUM POWER IN SELECTED GEARS**

Power Hp (kW)	Drawbar pull lbs (kN)	Speed mph (km/h)	Crank- shaft speed rpm	Slip %	Fuel Consumption lb/hp.hr (kg/kW.h)	Hp.hr/gal (kW.h/l)	D.E.F. Consumption lb/hp.hr (kg/kW.h)	Temp.°F cool- ing med	°C Air dry bulb	Barom. inch Hg (kPa)	
415.60 (309.91)	54741 (243.50)	2.85 (4.58)	2080	14.1	2nd Gear 0.485 (0.295)		14.46 (2.85)	0.052 (0.032)	199 (93)	78 (25)	28.63 (96.95)
457.46 (341.12)	49986 (222.35)	3.44 (5.53)	2008	11.1	3rd Gear 0.463 (0.282)		15.13 (2.98)	0.043 (0.026)	199 (93)	79 (26)	28.61 (96.88)
500.65 (373.33)	45700 (203.28)	4.11 (6.61)	1900	6.6	4th Gear 0.432 (0.263)		16.22 (3.19)	0.042 (0.025)	204 (95)	72 (22)	28.69 (97.16)
512.77 (382.37)	39895 (177.46)	4.82 (7.76)	1899	4.6	5th Gear 0.421 (0.256)		16.64 (3.28)	0.041 (0.025)	203 (95)	73 (23)	28.70 (97.19)
515.00 (384.04)	36148 (160.79)	5.34 (8.59)	1899	3.7	6th Gear 0.420 (0.255)		16.69 (3.29)	0.041 (0.025)	204 (95)	74 (23)	28.69 (97.16)
516.02 (384.79)	32767 (145.75)	5.91 (9.50)	1900	3.0	7th Gear 0.418 (0.254)		16.76 (3.30)	0.041 (0.025)	203 (95)	75 (24)	28.70 (97.19)
517.37 (385.80)	29747 (132.32)	6.52 (10.49)	1899	2.4	8th Gear 0.418 (0.254)		16.79 (3.31)	0.041 (0.025)	203 (95)	77 (25)	28.72 (97.26)
516.41 (385.09)	26886 (119.59)	7.20 (11.59)	1900	2.0	9th Gear 0.418 (0.254)		16.77 (3.30)	0.041 (0.025)	205 (96)	78 (25)	28.70 (97.19)
516.76 (385.34)	24394 (108.51)	7.95 (12.79)	1900	1.7	10th Gear 0.418 (0.254)		16.78 (3.31)	0.041 (0.025)	206 (96)	79 (26)	28.72 (97.26)

## HYDRAULIC PERFORMANCE

CATEGORY: IVN

Quick Attach: yes

OECD Static test

Maximum force exerted through whole range:	19728 lbs (87.8 kN)	
	<b>Three outlet sets combined</b>	
	<u>Standard pump</u>	<u>High flow pump</u>
i) Sustained pressure of the open relief valve:	2877 psi (198 bar)	3075 psi (212 bar)
ii) Pump delivery rate at minimum pressure and rated engine speed:	43.8 GPM (165.8 l/min)	59.0 GPM (223.4 l/min)
iii) Pump delivery rate at maximum hydraulic power:	43.3 GPM (163.7 l/min)	55.8 GPM (211.2 l/min)
Delivery pressure:	2526 psi (174 bar)	2664 psi (184 bar)
Power:	63.7 HP (47.5 kW)	86.7 Hp (64.6 kW)

### Single outlet set

ii) Pump delivery rate at minimum pressure and rated engine speed:	42.8 GPM (162.2 l/min)	47.3 GPM (179.0 l/min)
iii) Pump delivery rate at maximum hydraulic power:	42.7 GPM (161.6 l/min)	40.1 GPM (151.9 l/min)
Delivery pressure:	2024 psi (139 bar)	1999 psi (138 bar)
Power:	50.4 HP (37.6 kW)	46.8 Hp (34.9 kW)

### TwinFlow system

#### Two outlet sets combined

	<u>Standard pump</u>	<u>TwinFlow pump</u>
i) Sustained pressure at compensator cutoff:	2877 psi (198 bar)	2855 psi (197 bar)
ii) Pump delivery rate at minimum pressure and rated engine speed:	43.8 GPM (165.8 l/min)	57.3 GPM (217.0 l/min)
Combined flow:	101.1 GPM (382.8 l/min)	
iii) Pump delivery rate at maximum hydraulic power:	43.3 GPM (163.7 l/min)	56.4 GPM (213.6 l/min)
Delivery pressure:	2526 psi (174 bar)	2479 psi (171 bar)
Power:	63.7 HP (47.5 kW)	81.6 Hp (60.9 kW)

#### Two outlet sets combined

	<u>High flow pump</u>	<u>TwinFlow pump</u>
i) Sustained pressure at compensator cutoff:	2993 psi (206 bar)	2855 psi (197 bar)
ii) Pump delivery rate at minimum pressure and rated engine speed:	61.0 GPM (230.9 l/min)	57.3 GPM (217.0 l/min)
Combined flow:	118.3 GPM (447.9 l/min)	
iii) Pump delivery rate at maximum hydraulic power:	56.7 GPM (214.7 l/min)	56.4 GPM (213.6 l/min)
Delivery pressure:	2517 psi (174 bar)	2479 psi (171 bar)
Power:	83.3 HP (62.1 kW)	81.6 Hp (60.9 kW)

## HITCH DIMENSIONS AS TESTED - NO LOAD

	inch	mm
A	32.6	827
B	29.9	760
C	23.2	590
D	22.0	558
E	13.5	342
F	13.4	340
G	35.0	890
*G'	11.8	300
H	4.6	117
I	22.8	578
J	21.6	550
K	29.0	736
L	56.3	1431
*L'	63.6	1615
M	34.3	871
N	46.5	1181
O	7.9	200
P	45.4	1154
Q	40.9	1039
R	38.5	978

\*G' to undercarriage pivot point  
\*L' to Quick coupler ends

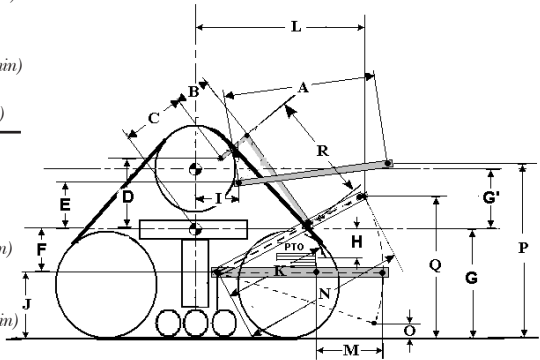

**Case IH Steiger 580 Quadtrac Diesel**