

# NEBRASKA OECD TRACTOR TEST 2122A—SUMMARY 985A

## CASE IH MAGNUM 250 DIESEL

### 18 SPEED

#### POWER TAKE-OFF PERFORMANCE

Power HP (kW)	Crank shaft speed rpm	Diesel Consumption		D.E.F. Consumption		Mean Atmospheric Conditions
		Gal/hr (l/h)	lb/hp.hr (kg/kW.h)	Hp.hr/gal (kW.h/l)	Gal/hr (l/h)	
<b>MAXIMUM POWER AND FUEL CONSUMPTION</b>						
<b>Rated Engine Speed—(PTO speed—1109 rpm)</b>						
215.51 (160.71)	2000	11.87 (44.92)	0.385 (0.234)	18.16 (3.58)	0.91 (3.45)	
<b>Standard Power Take-off Speed (998 rpm)</b>						
261.49 (194.99)	1800	13.52 (51.19)	0.361 (0.220)	19.34 (3.81)	1.18 (4.45)	
<b>Maximum Power (1 hour)</b>						
261.49 (194.99)	1800	13.52 (51.19)	0.361 (0.220)	19.34 (3.81)	1.18 (4.45)	

#### VARYING POWER AND FUEL CONSUMPTION

215.51 (160.71)	2000	11.87 (44.92)	0.385 (0.234)	18.16 (3.58)	0.91 (3.45)	Air temperature
192.02 (143.19)	2096	11.05 (41.84)	0.402 (0.245)	17.37 (3.42)	0.77 (2.91)	77°F (25°C)
146.19 (109.01)	2126	8.99 (34.05)	0.430 (0.261)	16.25 (3.20)	0.58 (2.21)	Relative humidity
99.04 (73.85)	2157	7.00 (26.51)	0.494 (0.301)	14.14 (2.79)	0.43 (1.63)	61%
49.85 (37.18)	2178	4.85 (18.35)	0.679 (0.413)	10.29 (2.03)	0.33 (1.25)	Barometer
1.64 (1.22)	2205	3.09 (11.71)	13.162 (8.006)	0.53 (0.10)	0.27 (1.04)	28.79" Hg (97.49 kPa)

Maximum torque - 878 lb.-ft. (1190 Nm) at 1399 rpm

Maximum torque rise - 55.0%

Torque rise at 1600 engine rpm - 48%

Power increase at 1800 engine rpm - 21.3%

#### DRAWBAR PERFORMANCE

##### UNBALLASTED - FRONT DRIVE ENGAGED FUEL CONSUMPTION CHARACTERISTICS

Power Hp (kW)	Drawbar pull lbs (kN)	Speed mph (km/h)	Crank- shaft speed rpm	Slip %	Fuel Consumption lb/hp.hr (kg/kW.h)	D.E.F Consumption lb/hp.hr (kg/kW.h)	Temp. °F(°C) cool- ing Air dry bulb	Barom. inch Hg (kPa)
<b>Power at Rated Engine Speed—8th Gear</b>								
183.85 (137.09)	13027 (37.95)	5.29 (8.51)	2000	4.6	0.446 (0.271)	15.66 (3.08)	0.044 (0.027)	202 (94)
<b>75% of Pull at Rated Engine Speed—8th Gear</b>								
147.32 (109.86)	9737 (43.31)	5.67 (9.12)	2117	3.2	0.480 (0.292)	14.55 (2.87)	0.041 (0.025)	198 (92)
<b>50% of Pull at Rated Engine Speed—8th Gear</b>								
100.38 (74.85)	6506 (28.94)	5.79 (9.32)	2133	2.0	0.546 (0.332)	12.81 (2.52)	0.042 (0.025)	196 (91)
<b>75% of Pull at Reduced Engine Speed—11th Gear</b>								
147.22 (109.78)	9762 (43.42)	5.66 (9.11)	1391	3.2	0.424 (0.258)	16.46 (3.24)	0.037 (0.022)	193 (89)
<b>50% of Pull at Reduced Engine Speed—11th Gear</b>								
100.67 (75.07)	6514 (28.97)	5.80 (9.33)	1408	2.0	0.456 (0.278)	15.31 (3.02)	0.039 (0.024)	196 (91)

**Location of tests:** Nebraska Tractor Test Laboratory, University of Nebraska, Lincoln, Nebraska 68583-0832

**Dates of tests:** September 1 - 17, 2015

**Manufacturer:** CNH America LLC, 700 State St. Racine, WI. 53404 USA

**CONSUMABLE Fluids, OIL and TIME: Fuel** No. 2 Diesel **Specific gravity converted to 60°/60°F (15°/15°C)** 0.8390 **Fuel weight** 6.986 lbs/gal (0.838 kg/l) **Diesel Exhaust Fluid (DEF)** 32% aqueous urea solution **DEF weight** 9.071 lbs/gal (1.087 kg/l) **Oil** SAE 10W40 **API service classification** CJ-4 **Transmission and hydraulic lubricant** Akcela Hy-tran Ultrtraction fluid **Front axle lubricant** SAE 85W-140 API GL-5 **Total time engine was operated:** 21.5 hours

**ENGINE: Make** F.P.T. Diesel **Type** six cylinder vertical with turbocharger, air to air intercooler and D.E.F. (diesel exhaust fluid) exhaust treatment **Serial No.** \*14H10077615\* **Crankshaft** lengthwise **Rated engine speed** 2000 **Bore and stroke** 4.606" x 5.315" (117.0 mm x 135.0 mm) **Compression ratio** 15.9 to 1 **Displacement** 531 cu in (8704 ml) **Starting system** 12 volt **Lubrication** pressure **Air cleaner** two paper elements and aspirator **Oil filter** one full flow cartridge **Oil cooler** engine coolant heat exchanger for crankcase oil, radiator for hydraulic and transmission oil **Fuel filter** two paper elements **Fuel cooler** radiator for pump return fuel **Exhaust** DOC (diesel oxidation catalyst) and SCR (selective catalyst reduction) integrated within a vertical muffler **Cooling medium temperature control** thermostat and variable speed fan

**ENGINE OPERATING PARAMETERS: Fuel rate:** 77.8 - 83.1 lb/h (35.3 - 37.7 kg/h) **High idle:** 2200 - 2250 rpm **Turbo boost:** nominal 17.5 - 19.4 psi (121 - 134 kPa) as measured 18.7 psi (129 kPa)

**CHASSIS: Type** front wheel assist **Serial No.** \*ZFRE01826\* **Tread width** rear 64.0" (1626 mm) to 129.0" (3277 mm) front 60.0" (1524 mm) to 88.0" (2235 mm) **Wheelbase** 120.3" (3055 mm) **Hydraulic control system** direct engine drive **Transmission** selective gear fixed ratio with full range operator controlled powershift **Nominal travel speeds mph (km/h)** first 2.06 (3.32) second 2.36 (3.80) third 2.73 (4.39) fourth 3.13 (5.03) fifth 3.59 (5.77) sixth 4.11 (6.62) seventh 4.80 (7.72) eighth 5.51 (8.86) ninth 6.35 (10.22) tenth 7.28 (11.72) eleventh 8.35 (13.44) twelfth 9.58 (15.42) thirteenth 11.94 (19.21) fourteenth 13.70 (22.04) fifteenth 15.80 (25.42) sixteenth 18.11 (29.15) seventeenth 20.79 (33.45) eighteenth 23.84 (38.37) reverse 2.96 (4.77), 3.41 (5.48), 6.91 (11.12), 7.92 (12.75)

**DRAWBAR PERFORMANCE**  
**UNBALLASTED - FRONT DRIVE ENGAGED**  
**MAXIMUM POWER IN SELECTED GEARS**

Power Hp (kW)	Drawbar pull lbs (kN)	Speed mph (km/h)	Crank- shaft speed rpm	Slip %	Fuel Consumption lb/hp.hr (kg/kW.h)	D.E.F Consumption lb/hp.hr (kg/kW.h)	Temp. °F(°C) cool- ing dry bulb	Air dry bulb	Barom. inch Hg (kPa)	
					<b>4th Gear</b>					
153.28 (114.30)	20729 (92.20)	2.78 (4.47)	2054	14.1	0.517 (0.314)	13.52 (2.66)	0.049 (0.030)	193 (89)	76 (25)	28.56 (96.72)
					<b>5th Gear</b>					
166.95 (124.49)	18929 (84.20)	3.31 (5.33)	2024	10.0	0.485 (0.295)	14.41 (2.84)	0.047 (0.029)	204 (96)	77 (25)	28.56 (96.72)
					<b>6th Gear</b>					
174.66 (130.24)	17153 (76.30)	3.82 (6.15)	2000	7.5	0.473 (0.288)	14.77 (2.91)	0.047 (0.029)	203 (95)	79 (26)	28.58 (96.78)
					<b>7th Gear</b>					
182.75 (136.27)	15040 (66.90)	4.56 (7.34)	2000	5.5	0.450 (0.274)	15.53 (3.06)	0.045 (0.027)	205 (96)	76 (25)	28.64 (96.99)
					<b>8th Gear</b>					
183.85 (137.09)	13027 (57.95)	5.29 (8.51)	2000	4.6	0.446 (0.271)	15.66 (3.08)	0.044 (0.027)	202 (94)	75 (24)	28.62 (96.92)
					<b>9th Gear</b>					
184.14 (137.31)	11228 (49.94)	6.15 (9.90)	1999	3.6	0.445 (0.271)	15.68 (3.09)	0.045 (0.027)	205 (96)	75 (24)	28.63 (96.95)
					<b>10th Gear</b>					
182.14 (135.82)	9629 (42.83)	7.09 (11.41)	1999	3.1	0.451 (0.275)	15.48 (3.05)	0.045 (0.027)	206 (96)	77 (25)	28.64 (96.99)
					<b>11th Gear</b>					
179.98 (134.21)	8250 (36.70)	8.18 (13.16)	2000	2.6	0.457 (0.278)	15.28 (3.01)	0.046 (0.028)	208 (98)	77 (25)	28.64 (96.99)

**Clutch** multiple wet disc electrohydraulically operated by foot pedal **Brakes** wet disc hydraulically operated by two foot pedals that can be locked together **Steering** hydrostatic **Power take-off** 1000 rpm at 1803 engine rpm **Unladen tractor mass** 24185 lb (10971 kg)

**REPAIRS AND ADJUSTMENTS:** No repairs or adjustments.

**NOTE:** The data on this summary was obtained from testing conducted on the New Holland T8.320 Diesel.

**REMARKS:** All test results were determined from observed data obtained in accordance with official OECD, SAE and Nebraska test procedures. This tractor did not meet the manufacturer's remote hydraulic flow claims of 44 GPM (166 l/min) nor 59 GPM (225 l/min). The manufacturer's remote hydraulic flow claim of 75 GPM (282 l/min) was not verified. The performance results on this summary were taken from a test conducted under the OECD Code 2 test procedure.

We, the undersigned, certify that this is a true and correct report of official Tractor Test No. **2122A**, Nebraska Summary 985A, January 22, 2016.

Roger M. Hoy  
 Director

M.F. Kocher  
 P.J. Jasa  
 J.D. Luck  
 Board of Tractor Test Engineers

<b>TRACTOR SOUND LEVEL WITH CAB</b>	<b>Front Wheel Drive</b>	
	<b>Engaged dB(A)</b>	<b>Disengaged dB(A)</b>
At no load in 7th gear	66.9	67.0
Bystander in 18th gear	66.9	82.6

**TIRES AND WEIGHT**

**Rear Tires** - No., size, ply & psi(kPa)  
**Front Tires** - No., size, ply & psi(kPa)  
**Height of Drawbar**  
**Static Weight with operator** - Rear  
 - Front  
 - Total

**Tested Without Ballast**

Two 480/80R50;\*\*\*;22(150)  
 Two 480/85R34;\*\*\*;16(110)  
 22.0 in (560 mm)  
 15170 lb (6881 kg)  
 9190 lb (4168 kg)  
 24360 lb (11049 kg)

**DRAWBAR PERFORMANCE AT 1800 ENGINE RPM**  
**UNBALLASTED - FRONT DRIVE ENGAGED**  
**MAXIMUM POWER IN SELECTED GEARS**

Power Hp (kW)	Drawbar pull lbs (kN)	Speed mph (km/h)	Crank- shaft speed rpm	Slip %	Fuel Consumption lb/hp.hr (kg/kW.h)	D.E.F Consumption lb/hp.hr (kg/kW.h)	Temp. <sup>o</sup> F(°C) cool- ing dry bulb	Barom. inch Hg (kPa)		
4th Gear										
153.55 (114.50)	20757 (92.33)	2.78 (4.47)	2054	14.1	0.517 (0.314)	13.52 (2.66)	0.049 (0.030)	193 (89)	76 (25)	28.56 (96.72)
5th Gear										
167.61 (124.98)	19020 (84.61)	3.31 (5.32)	2022	10.1	0.484 (0.294)	14.45 (2.85)	0.047 (0.029)	201 (94)	76 (25)	28.56 (96.72)
6th Gear										
181.78 (135.55)	18292 (81.36)	3.73 (6.00)	1979	8.7	0.471 (0.287)	14.83 (2.92)	0.048 (0.029)	207 (97)	79 (26)	28.58 (96.78)
7th Gear										
200.50 (149.51)	17454 (77.64)	4.31 (6.94)	1945	8.0	0.450 (0.273)	15.54 (3.06)	0.047 (0.029)	208 (98)	80 (27)	28.57 (96.75)
8th Gear										
211.84 (157.97)	16715 (74.35)	4.76 (7.65)	1859	7.4	0.438 (0.266)	15.95 (3.14)	0.048 (0.029)	208 (98)	81 (27)	28.58 (96.78)
9th Gear										
219.46 (163.65)	15332 (68.20)	5.37 (8.64)	1800	6.3	0.428 (0.260)	16.33 (3.22)	0.047 (0.029)	208 (98)	82 (28)	28.58 (96.78)
10th Gear										
223.29 (166.50)	13342 (59.35)	6.28 (10.10)	1800	4.8	0.419 (0.255)	16.66 (3.28)	0.047 (0.028)	208 (98)	79 (26)	28.64 (96.99)
11th Gear										
223.22 (166.45)	11519 (51.24)	7.27 (11.70)	1800	3.8	0.419 (0.255)	16.67 (3.28)	0.047 (0.028)	207 (97)	78 (25)	28.64 (96.99)
12th Gear										
221.63 (165.27)	9903 (44.05)	8.39 (13.50)	1800	3.3	0.421 (0.256)	16.59 (3.27)	0.047 (0.029)	207 (97)	78 (26)	28.63 (96.95)

## HYDRAULIC PERFORMANCE

CATEGORY: 3

Quick Attach: Yes

OECD Static test

Maximum force exerted through whole range:	14301 lbs (63.6 kN)
	<b>Standard pump</b> <b>High flow pump</b>
	three outlet sets combined
i) Sustained pressure at compensator cutoff:	2849 psi (196 bar)    2938 psi (203 bar)
ii) Pump delivery rate at minimum pressure and rated engine speed:	42.5 GPM (161.0 l/min)    57.9 GPM (219.1 l/min)
iii) Pump delivery rate at maximum hydraulic power:	42.1 GPM (159.4 l/min)    58.2 GPM (220.2 l/min)
Delivery pressure:	2622 psi (181 bar)    2524 psi (174 bar)
Power:	64.4 HP (48.0 kW)    85.7 hp (63.9 kW)
	single outlet set
i) Sustained pressure at compensator cutoff:	2837 psi (196 bar)    2885 psi (199 bar)
ii) Pump delivery rate at minimum pressure and rated engine speed:	42.1 GPM (159.5 l/min)    42.0 GPM (159.1 l/min)
iii) Pump delivery rate at maximum hydraulic power:	39.5 GPM (149.6 l/min)    36.9 GPM (139.9 l/min)
Delivery pressure:	2231 psi (154 bar)    2169 psi (150 bar)
Power:	51.5 HP (38.4 kW)    46.8 hp (34.9 kW)

## HITCH DIMENSIONS AS TESTED—NO LOAD

	inch	mm
A	30.3	770
B	20.5	520
C	22.9	581
D	20.7	525
E	10.5	266
F	15.7	400
G	36.6	930
H	3.5	90
I	20.9	530
J	20.9	530
K	30.2	768
L	51.0	1295
*L'	55.9	1420
M	25.0	636
N	43.1	1095
O	9.0	230
P	47.8	1215
Q	42.7	1085
R	38.6	980

\*L' to Quick Attach ends

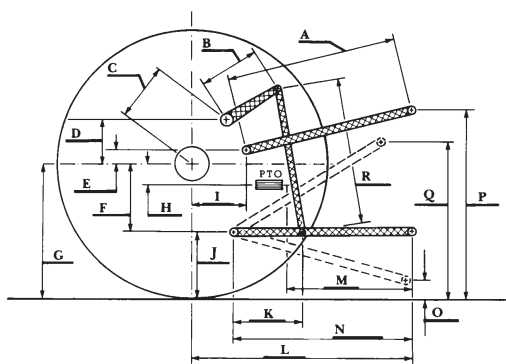

**CASE IH MAGNUM 250 DIESEL**