

NEBRASKA OECD TRACTOR TEST 2031 - SUMMARY 825

MASSEY FERGUSON 7497 DYNA VT DIESEL CONTINUOUSLY VARIABLE TRANSMISSION

POWER TAKE-OFF PERFORMANCE

Power HP (kW)	Crank shaft speed rpm	Gal/hr (l/h)	lb/hp.hr (kg/kW.h)	Hp.hr/gal (kW.h/l)	Mean Atmospheric Conditions
MAXIMUM POWER AND FUEL CONSUMPTION					
Rated Engine Speed—(PTO speed—1082 rpm)					
180.88 (134.88)	2201	11.14 (42.16)	0.435 (0.264)	16.24 (3.20)	
Standard Power Take-off Speed (1000 rpm)					
203.86 (152.02)	2035	11.80 (44.66)	0.408 (0.248)	17.28 (3.40)	
Maximum Power (1 Hour)					
207.82 (154.87)	1851	11.53 (43.63)	0.391 (0.238)	18.03 (3.55)	

VARYING POWER AND FUEL CONSUMPTION

180.88 (134.88)	2201	11.14 (42.16)	0.435 (0.264)	16.24 (3.20)	Air temperature
154.25 (115.02)	2218	10.12 (38.29)	0.463 (0.282)	15.25 (3.00)	74°F (23°C)
116.10 (86.58)	2228	8.03 (30.41)	0.488 (0.297)	14.45 (2.85)	Relative humidity
77.70 (57.94)	2236	5.94 (22.50)	0.540 (0.328)	13.07 (2.58)	35%
38.80 (28.93)	2248	3.83 (14.50)	0.697 (0.424)	10.13 (1.99)	Barometer
2.50 (1.86)	2255	2.19 (8.30)	6.190 (3.765)	1.14 (0.22)	28.96" Hg (98.07 kPa)

Maximum Torque - 659 lb.-ft. (894 Nm) at 1402 rpm
 Maximum Torque Rise - 52.7%
 Torque rise at 1800 engine rpm - 41%
 Power increase at 1851 rpm - 14.9%

DRAWBAR PERFORMANCE

UNBALLASTED - FRONT DRIVE ENGAGED FUEL CONSUMPTION CHARACTERISTICS

Power Hp (kW)	Drawbar pull lbs (kN)	Speed mph (km/h)	Crank- shaft speed rpm	Slip %	Fuel Consumption lb/hp.hr (kg/kW.h)	Hp.hr/gal (kW.h/l)	Temp. °F (°C) cool- ing dry med	Air bulb	Barom. inch Hg (kPa)
Maximum Power—5.6 mph (9.0 km/h)									
149.22 (111.27)	10193 (45.34)	5.49 (8.84)	2200	2.3	0.528 (0.321)	13.36 (2.63)	187 (86)	68 (20)	28.78 (97.46)
75% of Pull at Maximum Power—5.6 mph (9.0 km/h)									
112.07 (83.57)	7598 (33.80)	5.53 (8.90)	2221	1.6	0.600 (0.365)	11.76 (2.32)	188 (86)	86 (30)	28.56 (96.72)
50% of Pull at Maximum Power—5.6 mph (9.0 km/h)									
74.65 (55.66)	5022 (22.34)	5.58 (8.97)	2233	1.0	0.685 (0.417)	10.30 (2.03)	184 (84)	85 (29)	28.56 (96.72)
75% of Pull at Reduced Engine Speed—7.9 mph (12.7 km/h)									
112.63 (83.98)	7616 (33.88)	5.55 (8.92)	1576	1.6	0.505 (0.307)	13.99 (2.76)	191 (88)	87 (30)	28.57 (96.75)
50% of Pull at Reduced Engine Speed—9.0 mph (14.5 km/h)									
74.77 (55.75)	5026 (22.36)	5.58 (8.98)	1383	1.0	0.522 (0.317)	13.53 (2.67)	177 (81)	86 (30)	28.57 (96.75)

Location of tests: Nebraska Tractor Test Laboratory, University of Nebraska, Lincoln Nebraska 68583-0832

Dates of tests: June 12 - 18, 2012

Manufacturer: AGCO Corporation, 4205 River Green Parkway, Duluth, Georgia, 30096 USA.

FUEL, OIL and TIME: Fuel No. 2 Diesel Specific gravity converted to 60°/60°F (15°/15°C) 0.8475 Fuel weight 7.057 lbs/gal (0.846 kg/l) Oil SAE 15W40 API service classification CH-4 Transmission and hydraulic lubricant AGCO Power Fluid 821 XL fluid Front axle lubricant AGCO Gear Lube 715 SAE 80W90 Total time engine was operated 21.5 hours

ENGINE: Make Sisu Diesel Type six cylinder vertical with turbocharger and air to air intercooler Serial No. W23823 Crankshaft lengthwise Rated engine speed 2200 Bore and stroke 4.252" x 5.276" (108.0 mm x 134.0 mm) Compression ratio 17.5 to 1 Displacement 449 cu in (7365 ml) Starting system 12 volt Lubrication pressure Air cleaner two paper elements and aspirator Oil filter one full flow cartridge Oil cooler engine coolant heat exchanger for crankcase oil, radiator for hydraulic and final drive oil, radiator for transmission oil Fuel filter two paper elements and water separator Muffler vertical Cooling medium temperature control one thermostat and variable speed fan

ENGINE OPERATING PARAMETERS: Fuel rate: 78.0 - 81.8 lb/h (35.4 - 37.1 kg/h) High idle: 2225 - 2275 rpm Turbo boost: nominal 19.6 - 21.8 psi (135 - 150 kPa) as measured 20.6 psi (142 kPa)

CHASSIS: Type front wheel assist Serial No. B012038 Tread width rear 60.6" (1540 mm) to 119.9" (3045 mm) front 60.9" (1548 mm) to 88.8" (2256 mm) Wheelbase 118.4" (3007 mm) Hydraulic control system direct engine drive Transmission CVT. A combination of mechanical and hydrostatic sections allow an infinite speed adjustment within the ranges noted. The transmission has two mechanical ranges. Nominal travel speeds mph (km/h) forward: Low range 0-18 (0-30), high range 0-31 (0-50) reverse: Low range 0-13 (0-21), high range 0-17 (0-28) Clutch a foot pedal controls the hydrostatic oil flow Brakes wet multiple disc hydraulically actuated by two foot pedals which can be locked together Steering hydrostatic Power take-off 540 rpm at 2063 engine rpm or 1000 rpm at 2034 engine rpm Unladen tractor mass 17685 lb (8022 kg)

DRAWBAR PERFORMANCE
UNBALLASTED - FRONT DRIVE ENGAGED
MAXIMUM POWER AT SELECTED SPEEDS

Power Hp (kW)	Drawbar pull lbs (kN)	Speed mph (km/h)	Crank- shaft speed rpm	Slip %	Fuel Consumption lb/hp.hr (kg/kW.h)	Consumption Hp.hr/gal (kW.h/l)	Temp. ^o F(°C) cool- ing med	Air dry bulb	Barom. inch Hg (kPa)
128.80 (96.04)	17365 (77.24)	2.78 (4.47)	2213	11.3	0.604 (0.367)	11.69 (2.30)	189 (87)	78 (26)	28.27 (95.73)
144.10 (107.46)	15183 (67.54)	3.56 (5.73)	2200	5.1	0.549 (0.334)	12.86 (2.53)	189 (87)	78 (26)	28.27 (95.73)
146.98 (109.60)	13060 (58.09)	4.22 (6.79)	2200	3.7	0.539 (0.328)	13.10 (2.58)	190 (88)	78 (25)	28.74 (97.33)
147.03 (109.64)	12161 (54.09)	4.54 (7.30)	2200	3.2	0.539 (0.328)	13.09 (2.58)	190 (88)	76 (24)	28.74 (97.33)
147.97 (110.34)	11392 (50.67)	4.87 (7.84)	2200	2.7	0.534 (0.325)	13.21 (2.60)	188 (86)	75 (24)	28.74 (97.33)
149.22 (111.27)	10193 (45.34)	5.49 (8.84)	2200	2.3	0.528 (0.321)	13.36 (2.63)	187 (86)	68 (20)	28.78 (97.46)
148.39 (110.65)	9087 (40.42)	6.13 (9.86)	2200	2.0	0.530 (0.322)	13.31 (2.62)	188 (86)	68 (20)	28.78 (97.46)
147.11 (109.70)	8159 (36.29)	6.76 (10.88)	2200	1.7	0.538 (0.328)	13.11 (2.58)	188 (86)	69 (20)	28.76 (97.39)
145.57 (108.55)	7396 (32.90)	7.38 (11.88)	2200	1.6	0.540 (0.329)	13.07 (2.57)	188 (87)	72 (22)	28.75 (97.36)
141.97 (105.87)	6547 (29.12)	8.13 (13.08)	2201	1.4	0.553 (0.337)	12.75 (2.51)	191 (88)	80 (27)	28.74 (97.33)

REPAIRS AND ADJUSTMENTS: No repairs or adjustments.

REMARKS: All test results were determined from observed data obtained in accordance with official OECD, SAE and Nebraska test procedures. For the maximum power tests, the fuel temperature at the injection pump inlet was maintained at 138°F (59°C). The performance figures on this Summary were taken from a test conducted under the OECD Code 2 test procedure.

We, the undersigned, certify that this is a true and correct report of official Tractor Test No. **2031**, Nebraska Summary 825, September 8, 2012.

Roger M. Hoy
 Director

M.A. Hanna
 P.J. Jasa
 J.D. Luck
 Board of Tractor Test Engineers

TRACTOR SOUND LEVEL WITH CAB	Front Wheel Drive	
	Engaged dB(A)	Disengaged dB(A)
At no load - 4.6 mph (7.5 km/h)(engine - 2250 rpm)	68.0	68.0
At no load - 4.6 mph (7.5 km/h)(engine - 1240 rpm)	64.3	64.0
Bystander in Rabbit range	--	82.5

TIRES AND WEIGHT

Rear Tires—No., size, ply & psi (kPa)
Front Tires—No., size, ply & psi (kPa)
Height of Drawbar
Static Weight with operator—Rear
 —Front
 —Total

Tested Without Ballast

Two 480/80R46;***; 14 (95)
 Two 420/90R30;***; 14 (95)
 23.5 in (595 mm)
 10595 lb (4806 kg)
 7265 lb (3295 kg)
 17860 lb (8101 kg)

DRAWBAR PERFORMANCE AT 1850 ENGINE RPM

UNBALLASTED - FRONT DRIVE ENGAGED MAXIMUM POWER AT SELECTED SPEEDS

Power Hp (kW)	Drawbar pull lbs (kN)	Speed mph (km/h)	Crank- shaft speed rpm	Slip %	Fuel Consumption lb/hp.hr (kg/kW.h)	Consumption Hp.hr/gal (kW.h/l)	Temp. °F(°C) cool- ing med	Air dry bulb	Barom. inch Hg (kPa)
3.1 mph (5.0 km/h)									
130.28 (97.15)	17388 (77.34)	2.81 (4.52)	2214	10.4	0.599 (0.364)	11.78 (2.32)	188 (87)	77 (25)	28.27 (95.73)
3.7 mph (6.0 km/h)									
152.42 (113.66)	16429 (73.08)	3.48 (5.60)	2130	7.4	0.550 (0.335)	12.83 (2.53)	192 (89)	79 (26)	28.27 (95.73)
4.3 mph (7.0 km/h)									
166.54 (124.19)	15031 (66.86)	4.16 (6.69)	1944	5.2	0.503 (0.306)	14.04 (2.77)	196 (91)	80 (27)	28.27 (95.73)
4.7 mph (7.5 km/h)									
167.51 (124.91)	14025 (62.38)	4.48 (7.21)	1882	4.1	0.494 (0.300)	14.29 (2.81)	193 (89)	79 (26)	28.57 (96.75)
5.0 mph (8.0 km/h)									
172.50 (128.63)	13349 (59.38)	4.85 (7.80)	1850	3.5	0.475 (0.289)	14.84 (2.92)	190 (88)	74 (23)	28.57 (96.75)
5.6 mph (9.0 km/h)									
172.49 (128.63)	11805 (52.51)	5.48 (8.82)	1850	2.8	0.474 (0.288)	14.89 (2.93)	191 (88)	73 (23)	28.58 (96.78)
6.2 mph (10.0 km/h)									
172.04 (128.29)	10513 (46.76)	6.14 (9.87)	1852	2.4	0.476 (0.290)	14.82 (2.92)	192 (89)	74 (23)	28.58 (96.78)
6.8 mph (11.0 km/h)									
170.22 (126.93)	9451 (42.04)	6.76 (10.87)	1850	2.1	0.479 (0.291)	14.74 (2.90)	194 (90)	76 (24)	28.57 (96.75)
7.5 mph (12.0 km/h)									
168.29 (125.49)	8541 (37.99)	7.39 (11.89)	1850	1.8	0.487 (0.296)	14.50 (2.86)	192 (89)	76 (24)	28.57 (96.75)
8.2 mph (13.2 km/h)									
166.24 (123.97)	7647 (34.02)	8.16 (13.12)	1851	1.6	0.493 (0.300)	14.32 (2.82)	198 (92)	77 (25)	28.57 (96.75)

HYDRAULIC PERFORMANCE

CATEGORY: III

Quick Attach: None

OECD Static test

Maximum force exerted through whole range:	14283 lbs (63.5 kN)	
Pump size:	29.0 GPM (110 l/min)	39.0 GPM (150 l/min)
	two outlet sets combined	three outlet sets combined
i) Sustained pressure at compensator cutoff:	2916 psi (201 bar)	2889 psi (199 bar)
ii) Pump delivery rate at minimum pressure and rated engine speed:	30.0 GPM (113.6 l/min)	43.5 GPM (164.5 l/min)
iii) Pump delivery rate at maximum hydraulic power:	29.5 GPM (111.7 l/min)	40.2 GPM (152.1 l/min)
Delivery pressure:	2730 psi (188 bar)	2596 psi (179 bar)
Power:	47.0 HP (35.0 kW)	60.8 HP (45.4 kW)
	single outlet set	single outlet set
ii) Pump delivery rate at minimum pressure and rated engine speed:	29.1 GPM (110.2 l/min)	26.5 GPM (100.1 l/min)
iii) Pump delivery rate at maximum hydraulic power:	27.5 GPM (104.1 l/min)	26.4 GPM (99.9 l/min)
Delivery pressure:	2433 psi (168 bar)	2432 psi (168 bar)
Power:	39.0 HP (29.1 kW)	37.4 HP (27.9 kW)

HITCH DIMENSIONS AS TESTED - NO LOAD

	SAE TEST		OECD TEST	
	inch	mm	inch	mm
A	30.3	768	29.7	754
B	14.0	355	14.0	355
C	13.7	347	13.7	347
D	12.0	305	12.0	305
E	12.6	321	12.6	321
F	10.0	255	10.0	255
G	34.2	870	34.2	870
H	2.4	60	2.4	60
I	18.7	476	18.7	476
J	24.2	615	24.2	615
K	27.2	690	27.2	690
L	46.3	1175	46.3	1175
M	26.2	665	26.2	665
N	40.6	1030	40.6	1030
O	8.0	203	9.0	230
P	46.2	1173	51.2	1300
Q	37.3	947	39.5	1003
R	29.9	759	29.3	744

THREE POINT HITCH PERFORMANCE

Observed Maximum Pressure psi. (bar)	2850 (197)
Location:	lift cylinder
Hydraulic oil temperature: °F (°C)	148 (64)
Location:	hydraulic sump
Category:	III
Quick attach:	None
SAE Static Test —System pressure 2665 psi (177 Bar)	
Hitch point distance to ground level in. (mm)	8.2 (208) 14.4 (366) 20.8 (528) 27.2 (691) 33.6 (853) 40.0 (1016)
Lift force on frame lb	19719 17748 17721 18009 17874 16992
" " " " " " (kN)	(87.7) (78.9) (78.8) (80.1) (79.5) (75.6)

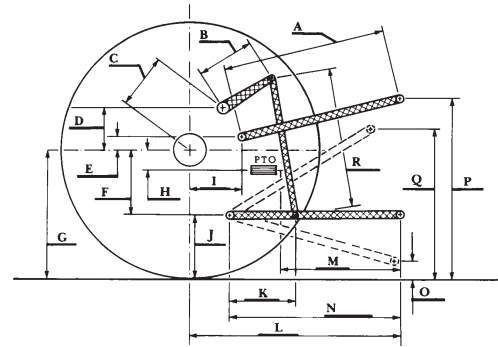

MASSEY FERGUSON 7497 Diesel