

NEBRASKA OECD TRACTOR TEST 1877 - SUMMARY 534

CHALLENGER MT 655B DIESEL

CONTINUOUSLY VARIABLE TRANSMISSION

POWER TAKE-OFF PERFORMANCE

Power HP (kW)	Crank shaft speed rpm	Gal/hr (l/h)	lb/hp.hr (kg/kW.h)	Hp.hr/gal (kW.h/l)	Mean Atmospheric Conditions
MAXIMUM POWER AND FUEL CONSUMPTION					
Rated Engine Speed—(PTO speed—1083 rpm)					
224.78 (167.62)	2200	13.51 (51.13)	0.420 (0.256)	16.64 (3.28)	
Standard Power Take-off Speed (1000 rpm)					
247.41 (184.49)	2030	13.65 (51.68)	0.386 (0.235)	18.12 (3.57)	
Maximum Power (1 Hour)					
252.36 (188.18)	2000	13.68 (51.80)	0.379 (0.231)	18.44 (3.63)	
VARYING POWER AND FUEL CONSUMPTION					
224.78 (167.62)	2200	13.51 (51.13)	0.420 (0.256)	16.64 (3.28)	Air temperature
192.54 (143.58)	2212	12.07 (45.71)	0.438 (0.267)	15.95 (3.14)	80°F (27°C)
144.43 (107.70)	2222	9.76 (36.93)	0.472 (0.287)	14.80 (2.92)	Relative humidity
96.80 (72.18)	2234	6.95 (26.32)	0.502 (0.305)	13.92 (2.74)	29%
48.90 (36.46)	2247	4.59 (17.38)	0.656 (0.399)	10.65 (2.10)	Barometer
1.59 (1.18)	2255	2.68 (10.13)	11.787 (7.170)	0.59 (0.12)	28.64" Hg (96.99 kPa)

Maximum Torque - 802 lb.-ft. (1087 Nm) at 1301 rpm
 Maximum Torque Rise - 49.3%
 Torque rise at 1801 engine rpm - 33%

DRAWBAR PERFORMANCE

UNBALLASTED - FRONT DRIVE ENGAGED

FUEL CONSUMPTION CHARACTERISTICS

Power Hp (kW)	Drawbar pull lbs (kN)	Speed mph (km/h)	Crank- shaft speed rpm	Slip %	Fuel Consumption lb/hp.hr (kg/kW.h)	Hp.hr/gal (kW.h/l)	Temp. °F (°C) cool- ing med	Air dry bulb	Barom. inch Hg (kPa)
Maximum Power—6.8 mph (11.0 km/h)									
185.25 (138.14)	10443 (46.45)	6.65 (10.71)	2197	3.22	0.514 (0.313)	13.59 (2.68)	187 (86)	71 (22)	28.43 (96.28)
75% of Pull at Maximum Power—6.8 mph (11.0 km/h)									
143.26 (106.83)	7827 (34.81)	6.86 (11.05)	2219	2.03	0.536 (0.326)	13.03 (2.57)	187 (86)	80 (27)	28.42 (96.24)
50% of Pull at Maximum Power—6.8 mph (11.0 km/h)									
97.13 (72.43)	5205 (23.15)	7.00 (11.26)	2229	1.20	0.617 (0.375)	11.33 (2.23)	187 (86)	82 (28)	28.41 (96.21)
75% of Pull at Reduced Engine Speed—9.1 mph (14.6 km/h)									
143.07 (106.69)	7793 (34.66)	6.88 (11.08)	1700	2.03	0.457 (0.278)	15.28 (3.01)	188 (87)	84 (29)	28.41 (96.21)
50% of Pull at Reduced Engine Speed—11.0 mph (17.7 km/h)									
97.29 (72.55)	5263 (11.16)	6.93 (11.16)	1399	1.20	0.467 (0.284)	14.96 (2.95)	181 (83)	83 (28)	28.41 (96.21)

Location of tests: Nebraska Tractor Test Laboratory, University of Nebraska, Lincoln Nebraska 68583-0832

Dates of tests: April 11-19, 2006

Manufacturer: AGCO Corporation, 4205 River Green Parkway, Duluth, Georgia, 30096 USA.

FUEL, OIL and TIME: Fuel No. 2 Diesel Specific gravity converted to 60°/60° F (15°/15°C) 0.8395 Fuel weight 6.990 lbs/gal (0.838 kg/l) Oil SAE 15W40 API service classification CE/CF-4 /CD-II Transmission and hydraulic lubricant AGCO Power Fluid 821 XL fluid Front axle lubricant AGCO Gear Lube 715 SAE 80W90 Total time engine was operated 27.0 hours

ENGINE: Make Sisu Diesel Type six cylinder vertical with turbocharger and air to air intercooler **Serial No.** R09649 **Crankshaft** lengthwise **Rated engine speed** 2200 **Bore and stroke** 4.370" x 5.709" (111.0 mm x 145.0 mm) **Compression ratio** 17.5 to 1 **Displacement** 513 cu in (8420 ml) **Starting system** 12 volt **Lubrication** pressure **Air cleaner** two paper elements and aspirator **Oil filter** one full flow cartridge **Oil cooler** engine coolant heat exchanger for crankcase oil, radiator for hydraulic and final drive oil, radiator for transmission oil **Fuel filter** two paper elements and water separator **Muffler** vertical **Cooling medium temperature control** one thermostat and variable speed fan

ENGINE OPERATING PARAMETERS: Fuel rate: 91.3 - 96.8 lb/h (41.4 - 43.9 kg/h) **High idle:** 2235 - 2265 rpm **Turbo boost:** nominal 16.2 - 19.9 psi (112 - 137 kPa) as measured 18.6 psi (128 kPa)

CHASSIS: Type front wheel assist **Serial No.** P244056 **Tread width** rear 60.0" (1524 mm) to 126.0" (3200 mm) front 68.5" (1740 mm) to 93.3" (2369 mm) **Wheelbase** 121.1" (3075 mm) **Hydraulic control system** direct engine drive **Transmission** Techstar CVT. A combination of mechanical and hydrostatic sections allow an infinite speed adjustment within the ranges noted. The transmission has two mechanical ranges. **Nominal travel speeds mph (km/h)** forward: Low range 0-17 (0-28), high range 0-25 (0-40) reverse: Low range 0-10 (0-16), high range 0-24 (0-38) **Clutch** a foot pedal controls the hydrostatic oil flow **Brakes** wet multiple disc hydraulically actuated by two foot pedals which can be locked together **Steering** hydrostatic **Power take-off** 540 rpm at 2062 engine rpm or 1000 rpm at 2033 engine rpm **Unladen tractor mass** 20290 lb (9203 kg)

DRAWBAR PERFORMANCE
UNBALLASTED - FRONT DRIVE ENGAGED
MAXIMUM POWER AT SELECTED SPEEDS

Power Hp (kW)	Drawbar pull lbs (kN)	Speed mph (km/h)	Crank- shaft speed rpm	Slip %	Fuel Consumption lb/hp.hr (kg/kW.h)	Consumption Hp.hr/gal (kW.h/l)	Temp. °F(°C) cool- ing med	Air dry bulb	Barom. inch Hg (kPa)
3.7 mph(6.0 km/h)									
161.38 (120.34)	18319 (81.49)	3.30 (5.32)	2203	10.63	0.522 (0.318)	13.38 (2.64)	187 (86)	52 (11)	28.80 (97.53)
4.3 mph(7.0 km/h)									
181.50 (135.34)	16790 (74.68)	4.05 (6.52)	2197	8.00	0.512 (0.311)	13.65 (2.69)	187 (86)	54 (12)	28.82 (97.60)
4.7 mph(7.5 km/h)									
188.09 (140.26)	16227 (72.18)	4.35 (7.00)	2179	7.22	0.502 (0.305)	13.93 (2.74)	187 (86)	56 (13)	28.83 (97.63)
5.0 mph(8.0 km/h)									
191.91 (143.10)	15534 (69.10)	4.63 (7.46)	2156	6.50	0.490 (0.298)	14.27 (2.81)	187 (86)	58 (14)	28.84 (97.66)
5.6 mph(9.0 km/h)									
200.71 (149.67)	15060 (66.99)	5.00 (8.04)	2078	6.06	0.471 (0.287)	14.84 (2.92)	187 (86)	60 (16)	28.85 (97.70)
6.2 mph(10.0 km/h)									
207.17 (154.48)	14749 (65.60)	5.27 (8.48)	1995	5.63	0.465 (0.283)	15.04 (2.96)	188 (87)	70 (21)	28.43 (96.28)
6.8 mph(11.0 km/h)									
208.23 (155.28)	13183 (58.64)	5.92 (9.53)	2000	4.24	0.457 (0.278)	15.29 (3.01)	188 (87)	69 (21)	28.43 (96.28)
7.5 mph(12.0 km/h)									
205.73 (153.41)	11662 (51.88)	6.62 (10.65)	2003	3.73	0.465 (0.283)	15.02 (2.96)	189 (87)	70 (21)	28.43 (96.28)
8.1 mph(13.0 km/h)									
205.89 (153.53)	10921 (48.58)	7.07 (11.38)	1999	3.32	0.466 (0.284)	15.00 (2.95)	189 (87)	72 (22)	28.43 (96.28)
8.7 mph(14.0 km/h)									
202.61 (151.08)	9870 (43.90)	7.70 (12.39)	2005	2.94	0.472 (0.287)	14.82 (2.92)	189 (87)	73 (23)	28.43 (96.28)
9.3 mph(15.0 km/h)									
202.45 (150.97)	9313 (41.43)	8.15 (13.12)	2003	2.58	0.473 (0.288)	14.77 (2.91)	189 (87)	77 (25)	28.42 (96.24)

REPAIRS AND ADJUSTMENTS: No repairs or adjustments.

NOTE: The performance figures on this report are the result of replacing the electronic engine control module of the Challenger MT 665B with the MT 655B module.

REMARKS: All test results were determined from observed data obtained in accordance with official OECD, SAE and Nebraska test procedures. The pull at speed setting 2.7 mph (4.3 km/h) was limited to avoid excessive tractor bouncing. This tractor did not meet the manufacturer's claim of 39.0 GPM (147 lpm) flow at the remote outlets. For the maximum power tests, the fuel temperature at the injection pump inlet was maintained at 134°F (56°C). The performance figures on this Summary were taken from a test conducted under the OECD Code II test procedure.

We, the undersigned, certify that this is a true and correct report of official Tractor Test No. **1877**, Nebraska Summary 534, June 16, 2006.

Leonard L. Bashford
 Director

M.F. Kocher
 V.I. Adamchuk
 J.A. Smith
 Board of Tractor Test Engineers

TRACTOR SOUND LEVEL WITH CAB	Front Wheel Drive	
	Engaged dB(A)	Disengaged dB(A)
At no load - 4.6 mph(7.5 km/h)(engine - 2250 rpm)	69.5	69.5
Bystander in Rabbit range	--	85.0

TIRES, BALLAST AND WEIGHT

	With Ballast	Without Ballast
Rear tires - No., size, ply & psi(kPa)	Four 480/80R46; ***,12(85)	Two 480/80R46; ***,22(150)
Ballast - Duals(total)	2190 lb (993 kg)	None
- Cast iron(total)	2525 lb (1145 kg)	None
Front tires - No., size, ply & psi(kPa)	Two 380/85R34; **,23(160)	Two 380/85R34; **,17(115)
Ballast - Liquid(total)	None	None
- Cast Iron(total)	1400 lb (635 kg)	None
Height of Drawbar	19.5 in (495 mm)	20.0 in (510 mm)
Static Weight with operator - Rear	16655 lb (7555 kg)	12375 lb (5613 kg)
- Front	9925 lb (4502 kg)	8090 lb (3670 kg)
- Total	26580 lb(12057 kg)	20465 lb(9283 kg)

DRAWBAR PERFORMANCE
BALLASTED - SINGLE FRONT TIRES
MAXIMUM POWER AT SELECTED SPEEDS

Power Hp (kW)	Drawbar pull lbs (kN)	Speed mph (km/h)	Crank- shaft speed rpm	Slip % lb/hp.hr (kg/kW.h)	Fuel Consumption Hp.hr/gal (kW.h/l)	cool- ing med	Temp. °F(°C) Air dry bulb	Barom. inch Hg (kPa)
150.93 (112.55)	24615 (109.49)	2.30 (3.70)	2196	11.59 2.7 mph (4.3 km/h) 0.547 (0.333)	12.78 (2.52)	187 (86)	57 (14)	28.65 (97.02)
180.25 (134.42)	23267 (103.50)	2.91 (4.68)	2172	8.72 3.1 mph (5.0 km/h) 0.529 (0.322)	13.22 (2.60)	187 (86)	57 (14)	28.65 (97.02)
196.21 (146.31)	22172 (98.63)	3.32 (5.34)	2111	6.45 3.7 mph (6.0 km/h) 0.484 (0.294)	14.44 (2.84)	187 (86)	57 (14)	26.65 (97.02)
208.34 (155.36)	20930 (93.10)	3.73 (6.01)	2000	5.58 4.3 mph (7.0 km/h) 0.458 (0.279)	15.26 (3.01)	188 (87)	57 (14)	28.66 (97.05)
209.04 (155.88)	19265 (85.70)	4.07 (6.55)	2000	4.48 4.7 mph (7.5 km/h) 0.458 (0.278)	15.27 (3.01)	189 (87)	57 (14)	28.66 (97.05)
215.10 (160.40)	18584 (82.67)	4.34 (6.99)	2004	3.96 5.0 mph (8.0 km/h) 0.445 (0.270)	15.72 (3.10)	188 (87)	56 (13)	28.66 (97.05)
215.13 (160.42)	16465 (73.24)	4.90 (7.89)	2004	3.23 5.6 mph (9.0 km/h) 0.448 (0.272)	15.62 (3.08)	189 (87)	56 (13)	28.67 (97.08)
215.56 (160.74)	14836 (65.99)	5.45 (8.77)	2001	2.81 6.2 mph (10.0 km/h) 0.442 (0.269)	15.81 (3.11)	188 (87)	56 (13)	28.67 (97.08)
214.57 (160.01)	13287 (59.11)	6.06 (9.75)	2004	2.44 6.8 mph (11.0 km/h) 0.447 (0.272)	15.62 (3.08)	188 (87)	56 (13)	28.67 (97.08)
211.90 (158.02)	11837 (52.65)	6.71 (10.80)	1999	2.19 7.5 mph (12.0 km/h) 0.455 (0.277)	15.35 (3.02)	188 (87)	57 (14)	28.67 (97.08)
211.49 (157.71)	10990 (48.89)	7.22 (11.61)	2003	1.99 8.1 mph (13.0 km/h) 0.454 (0.276)	15.39 (3.03)	188 (87)	57 (14)	28.67 (97.08)
209.61 (156.30)	10016 (44.55)	7.85 (12.63)	1996	1.80 8.7 mph (14.0 km/h) 0.453 (0.276)	15.43 (3.04)	188 (87)	57 (14)	28.68 (97.12)
206.88 (154.27)	9225 (41.03)	8.41 (13.53)	2004	1.68 9.3 mph (15.0 km/h) 0.462 (0.281)	15.13 (2.98)	188 (87)	57 (14)	28.68 (97.12)

DRAWBAR PERFORMANCE
BALLASTED -DUAL FRONT TIRES
MAXIMUM POWER AT SELECTED SPEEDS

Power Hp (kW)	Drawbar pull lbs (kN)	Speed mph (km/h)	Crank- shaft speed rpm	Slip %	Fuel Consumption lb/hp.hr (kg/kW.h)	Temp. °F(°C) cool- ing med	Barom. inch Hg (kPa)		
2.5 mph (4.0 km/h)									
153.48 (114.45)	26854 (119.45)	2.14 (3.45)	2213	11.45	0.562 (0.342)	12.44 (2.45)	187 (86)	58 (14)	28.42 (96.24)
2.8 mph (4.5 km/h)									
174.05 (129.79)	25765 (114.61)	2.53 (4.08)	2179	9.25	0.542 (0.330)	12.89 (2.54)	187 (86)	58 (14)	28.42 (96.24)
3.1 mph (5.0 km/h)									
184.70 (137.73)	24280 (108.00)	2.85 (4.59)	2124	7.00	0.509 (0.309)	13.75 (2.71)	187 (86)	58 (14)	28.42 (96.24)
3.7 mph (6.0 km/h)									
202.54 (151.03)	23493 (104.50)	3.23 (5.20)	2033	5.57	0.470 (0.286)	14.86 (2.93)	188 (87)	58 (14)	28.42 (96.24)
4.3 mph (7.0 km/h)									
210.54 (157.00)	20773 (92.40)	3.80 (6.12)	2000	4.02	0.453 (0.276)	15.43 (3.04)	188 (87)	58 (14)	28.42 (96.24)
4.7 mph (7.5 km/h)									
214.03 (159.60)	19525 (86.85)	4.11 (6.62)	2001	3.46	0.446 (0.271)	15.69 (3.09)	188 (87)	58 (14)	28.42 (96.24)
5.0 mph (8.0 km/h)									
214.27 (159.78)	18318 (81.48)	4.39 (7.06)	2000	3.11	0.443 (0.270)	15.78 (3.11)	188 (87)	58 (14)	28.43 (96.28)
5.6 mph (9.0 km/h)									
215.07 (160.38)	16358 (72.76)	4.93 (7.93)	2000	2.55	0.447 (0.272)	15.64 (3.08)	189 (87)	59 (15)	28.43 (96.28)
6.2 mph (10.0 km/h)									
215.23 (160.50)	14754 (65.63)	5.47 (8.80)	2002	2.29	0.446 (0.271)	15.67 (3.09)	189 (87)	59 (15)	28.43 (96.28)
6.8 mph (11.0 km/h)									
213.26 (159.03)	13248 (58.93)	6.04 (9.71)	2001	1.98	0.446 (0.271)	15.69 (3.09)	188 (87)	59 (15)	28.44 (96.31)
7.5 mph (12.0 km/h)									
212.23 (158.26)	11976 (53.27)	6.65 (10.69)	2000	1.75	0.446 (0.271)	15.69 (3.09)	188 (87)	59 (15)	28.45 (96.34)
8.1 mph (13.0 km/h)									
209.91 (156.53)	10848 (48.25)	7.26 (11.68)	2001	1.58	0.453 (0.276)	15.43 (3.04)	188 (87)	60 (16)	28.45 (96.34)
8.7 mph (14.0 km/h)									
208.68 (155.61)	9928 (44.16)	7.88 (12.69)	2001	1.37	0.457 (0.278)	15.29 (3.01)	188 (87)	60 (16)	28.46 (96.38)
9.3 mph (15.0 km/h)									
207.10 (154.43)	9364 (41.65)	8.29 (13.35)	2002	1.26	0.466 (0.283)	15.01 (2.96)	188 (87)	60 (16)	28.46 (96.38)

TIRES, BALLAST AND WEIGHT

Rear tires - No., size, ply & psi (kPa)
 Ballast - Duals (total)
 - Cast iron (total)
Front tires - No., size, ply & psi (kPa)
 Ballast - Duals (total)
 - Cast Iron (total)
Height of Drawbar
Static Weight with operator - Rear
 - Front
 - Total

With Ballast

Four 480/80R46; ***, 13 (90)
 2190 lb (993 kg)
 3285 lb (1490 kg)
 Four 380/85R34; **, 14 (95)
 1140 lb (517 kg)
 1600 lb (726 kg)
 19.5 in (495 mm)
 17355 lb (7872 kg)
 11325 lb (5137 kg)
 28680 lb (13009 kg)

Without Ballast

Two 480/80R46; ***, 22 (150)
 None
 None
 Two 380/85R34; **, 17 (115)
 None
 None
 20.0 in (510 mm)
 12375 lb (5613 kg)
 8090 lb (3670 kg)
 20465 lb (9283 kg)

THREE POINT HITCH PERFORMANCE (OECD Static Test)

CATEGORY: III

Quick Attach: Yes

Maximum force exerted through whole range:	15895 lbs (70.7 kN)
i) Opening pressure of relief valve:	NA
Sustained pressure of the open relief valve:	2801 psi (193 bar)
ii) Pump delivery rate at minimum pressure and rated engine speed:	38.1 GPM (144.2 l/min)
iii) Pump delivery rate at maximum hydraulic power:	36.3 GPM (137.4 l/min)
Delivery pressure:	2462 psi (170 bar)
Power:	52.1 HP (38.9 kW)

HITCH DIMENSIONS AS TESTED - NO LOAD

	OECD test		SAE test	
	inch	mm	inch	mm
A	29.2	743	29.2	743
B	14.2	360	14.2	360
C	17.7	449	17.7	449
D	15.4	390	15.4	390
E	8.9	225	8.9	225
F	13.0	330	13.0	330
G	36.2	920	36.2	920
H	3.4	85	3.4	85
I	18.7	475	18.7	475
J	23.2	590	23.2	590
K	26.8	680	26.8	680
L	50.4	1281	50.4	1281
*L'	55.4	1407	55.4	1407
M	27.9	709	27.9	709
N	41.1	1045	41.1	1045
O	9.0	230	8.0	203
P	46.2	1173	46.2	1173
Q	39.8	1011	38.6	981
R	34.5	876	35.0	889

*L' to Quick Attach ends

THREE POINT HITCH PERFORMANCE

Observed Maximum Pressure psi. (bar)	2800 (193)
Location:	lift cylinder
Hydraulic oil temperature: °F (°C)	150 (66)
Location:	hydraulic sump
Category:	III
Quick attach:	Yes
SAE Static Test—System pressure 2520 psi (174 Bar)	
Hitch point distance to ground level in. (mm)	8.6 (217) 16.3 (414) 24.4 (620) 32.3 (820) 40.3 (1024)
Lift force on frame lb	16726 17682 17713 17118 15672
" " " " " " (kN)	(74.7) (78.7) (78.8) (76.1) (69.7)

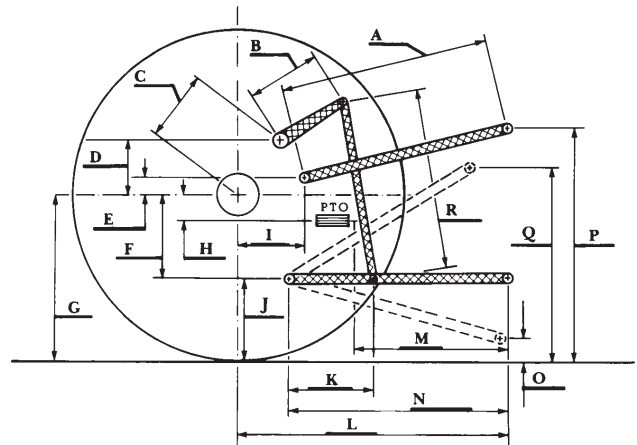

Challenger MT 655B Diesel