

NEBRASKA OECD TRACTOR TEST 2041-SUMMARY 832

JOHN DEERE 9460RT DIESEL

18 SPEED

POWER TAKE-OFF PERFORMANCE

Power HP (kW)	Crank shaft speed rpm	Gal/hr (l/h)	lb/hp.hr (kg/kW.h)	Hp.hr/gal (kW.h/l)	Mean Atmospheric Conditions
MAXIMUM POWER AND FUEL CONSUMPTION					
SEE NOTE 1 - PAGE 2					
Rated Engine Speed—(PTO speed—1108 rpm)					
316.03 (235.67)	2099	20.90 (79.12)	0.466 (0.284)	15.12 (2.98)	Fuel used during active exhaust regeneration - 2.72 gal (10.31 l) (see Note 2 p.2)
Standard Power Take-off Speed—(PTO speed—1000 rpm)					
349.30 (260.47)	1895	21.13 (79.99)	0.427 (0.259)	16.53 (3.26)	
Maximum Power (1 hour)					
359.80 (268.30)	1650	20.67 (78.24)	0.405 (0.246)	17.41 (3.43)	

VARYING POWER AND FUEL CONSUMPTION

316.03 (235.67)	2099	20.90 (79.12)	0.466 (0.284)	15.12 (2.98)	Air temperature
268.55 (200.26)	2099	18.94 (71.71)	0.497 (0.302)	14.18 (2.79)	78°F (25°C)
203.05 (151.41)	2119	16.03 (60.69)	0.557 (0.339)	12.67 (2.49)	Relative humidity
136.80 (102.01)	2142	12.95 (49.03)	0.668 (0.406)	10.56 (2.08)	32%
69.05 (51.49)	2164	9.87 (37.37)	1.008 (0.613)	6.99 (1.38)	Barometer
4.25 (3.17)	2179	7.02 (26.56)	11.638 (7.079)	0.61 (0.12)	28.71" Hg (97.22 kPa)

Maximum Torque - 1193 lb.-ft. (1617 Nm) at 1402 rpm
 Maximum Torque Rise - 50.7%
 Torque rise at 1679 engine rpm - 41%
 Power increase at 1650 engine rpm - 13.8%

DRAWBAR PERFORMANCE (Unballasted)

FUEL CONSUMPTION CHARACTERISTICS

Power Hp (kW)	Drawbar pull lbs (kN)	Speed mph (km/h)	Crank- shaft speed rpm	Slip %	Fuel Consumption lb/hp.hr (kg/kW.h)	Hp.hr/gal (kW.h/l)	Temp. °F (°C) cool- ing med	Air dry bulb	Barom. inch Hg (kPa)
Maximum Power—7th Gear									
353.03 (263.25)	25932 (115.35)	5.11 (8.22)	2101	1.5	0.480 (0.292)	14.69 (2.89)	191 (88)	73 (23)	28.79 (97.49)
75% of Pull at Maximum Power—7th Gear									
275.27 (205.27)	19530 (86.87)	5.29 (8.51)	2163	1.1	0.533 (0.324)	13.22 (2.60)	188 (86)	75 (24)	28.64 (96.99)
50% of Pull at Maximum Power—7th Gear									
186.11 (138.78)	13007 (57.86)	5.37 (8.63)	2186	0.5	0.641 (0.390)	11.00 (2.17)	188 (87)	77 (25)	28.64 (96.99)
75% of Pull at Reduced Engine Speed—10th Gear									
275.44 (205.39)	19569 (87.04)	5.28 (8.50)	1580	1.1	0.449 (0.273)	15.71 (3.09)	197 (92)	75 (24)	28.63 (96.95)
50% of Pull at Reduced Engine Speed—10th Gear									
186.38 (138.98)	13005 (57.85)	5.38 (8.65)	1601	0.5	0.497 (0.302)	14.20 (2.80)	188 (96)	76 (24)	28.63 (96.95)

Location of tests: Nebraska Tractor Test Laboratory, University of Nebraska, Lincoln, Nebraska 68583-0832

Dates of tests: September 20 - October 3, 2012

Manufacturer: John Deere Tractor Works, 3500 East Donald St., P.O. Box 270, Waterloo Ia, 50704-0270

FUEL, OIL and TIME: Fuel No. 2 Diesel Specific gravity converted to 60°/60°F (15°/15°C) 0.8467 Fuel weight 7.050 lbs/gal (0.845 kg/l) Oil SAE 15W-40 API service classification CJ-4 Transmission and hydraulic lubricant John Deere Hy-Gard fluid Total time engine was operated: 35.5 hours

ENGINE: Make John Deere Diesel **Type** six cylinder vertical with two turbochargers and air to air aftercooler **Serial No.** *RG6135R005949* **Crankshaft** lengthwise **Rated engine speed** 2100 **Bore and stroke** 5.197" x 6.496" (132.0 mm x 165.0 mm) **Compression ratio** 16.0 to 1 **Displacement** 826 cu in (13548 ml) **Starting system** 12 volt **Lubrication** pressure **Air cleaner** two paper elements and aspirator **Oil filter** one full flow cartridge **Oil cooler** engine coolant heat exchanger for crankcase oil, separate radiators for hydraulic and transmission oil, radiator for rear axle oil **Fuel filter** two paper cartridges **Fuel cooler** radiator for returned fuel **Exhaust** regenerative particulate filter integrated within a vertical muffler **Cooling medium temperature control** 3 thermostats and variable speed fan

ENGINE OPERATING PARAMETERS: Fuel rate: Stationary PTO operation 141.5 - 153.4 lb/h (64.2 - 69.6 kg/h), (410 engine hp) 144.6 - 156.7 lb/h (65.6 - 71.1 kg/h), (460 engine hp) 161.8 - 174.6 lb/h (73.4 - 79.5 kg/h) **High idle:** 2215 - 2265 rpm (2160 - 2200 rpm with PTO engaged) **Turbo boost:** (460 engine hp) nominal 29.7 - 34.1 psi (205 - 235 kPa) as measured 32.0 psi (220 kPa)

CHASSIS: Type tracklayer-rubber tracked **Serial No.** *1RW9460RJCPO1594* **Track width** 107.4" (2728 mm) **Length of track on ground** 111.0" (2819 mm) **Hydraulic control system** direct engine drive **Transmission** selective gear fixed ratio with full range operator controlled power shift **Nominal travel speeds mph (km/h)** first 2.51 (4.04) second 3.09 (4.97) third 3.41 (5.49) fourth 3.82 (6.14) fifth 4.20 (6.76) sixth 4.70 (7.56) seventh 5.20 (8.36) eighth 5.77 (9.29) ninth 6.39 (10.29) tenth 7.10 (11.43) eleventh 7.85 (12.63) twelfth 8.73 (14.05) thirteenth 9.66 (15.55) fourteenth 10.75 (17.30) fifteenth 13.29 (21.39) sixteenth 16.35 (26.31) seventeenth 20.07 (32.30) eighteenth 24.72 (39.77) reverse 2.51 (4.04), 3.41 (5.49), 3.82 (6.14), 5.20 (8.36), 5.77 (9.29), 7.85 (12.63)

DRAWBAR PERFORMANCE

(Unballasted at 2100 rpm)

MAXIMUM POWER IN SELECTED GEARS

Power Hp (kW)	Drawbar pull lbs (kN)	Speed mph (km/h)	Crank- shaft speed rpm	Slip %	Fuel Consumption lb/hp.hr (kg/kW.h)	Consumption Hp.lhr/gal (kW.h/l)	Temp.°F (°C) cool- ing med	Air dry bulb	Barom. inch Hg (kPa)
1st Gear									
281.48 (209.90)	45777 (203.63)	2.31 (3.71)	2100	7.9	0.545 (0.331)	12.95 (2.55)	188 (87)	64 (18)	28.79 (97.49)
2nd Gear									
295.70 (220.50)	37503 (166.82)	2.96 (4.76)	2101	4.0	0.518 (0.315)	13.62 (2.68)	189 (87)	66 (19)	28.77 (97.43)
3rd Gear									
304.25 (226.88)	34651 (154.13)	3.29 (5.29)	2101	3.4	0.500 (0.304)	14.09 (2.78)	189 (87)	69 (21)	28.75 (97.36)
4th Gear									
346.55 (258.42)	35209 (156.62)	3.69 (5.94)	2101	3.7	0.487 (0.297)	14.46 (2.85)	190 (88)	60 (16)	28.61 (96.88)
5th Gear									
351.23 (261.91)	32282 (143.60)	4.08 (6.57)	2101	2.6	0.479 (0.291)	14.72 (2.90)	190 (88)	73 (23)	28.76 (97.39)
6th Gear									
348.32 (259.74)	28419 (126.41)	4.60 (7.40)	2101	1.9	0.482 (0.293)	14.64 (2.88)	192 (89)	73 (23)	28.77 (97.43)
7th Gear									
353.03 (263.25)	25932 (115.35)	5.11 (8.22)	2101	1.5	0.480 (0.292)	14.69 (2.89)	191 (88)	73 (23)	28.79 (98.49)
8th Gear									
355.76 (265.29)	23460 (104.36)	5.69 (9.16)	2101	1.3	0.474 (0.288)	14.88 (2.93)	193 (89)	74 (23)	28.74 (97.33)
9th Gear									
351.78 (262.32)	20878 (92.87)	6.32 (10.17)	2101	1.0	0.476 (0.289)	14.81 (2.92)	194 (90)	75 (24)	28.73 (97.29)
10th Gear									
348.73 (260.05)	18647 (82.94)	7.02 (11.29)	2100	0.8	0.481 (0.293)	14.66 (2.89)	197 (92)	78 (25)	28.72 (97.26)
11th Gear									
348.64 (259.98)	16824 (74.83)	7.78 (12.51)	2100	0.7	0.483 (0.294)	14.59 (2.88)	199 (93)	78 (26)	28.71 (97.22)
12th Gear									
351.29 (261.95)	15184 (67.54)	8.68 (13.96)	2100	0.4	0.479 (0.291)	14.73 (2.90)	198 (92)	79 (26)	28.69 (97.16)

Clutch wet multiple disc hydraulically actuated by foot pedal **Brakes** wet multiple disc hydraulically actuated foot pedal **Steering** electro-hydraulic differential steering controlled by steering wheel **Power take-off** 1000 rpm at 1895 engine rpm **Unladen tractor mass** 46845 lb (21248 kg)

REPAIRS AND ADJUSTMENTS: No repairs or adjustments.

NOTE 1. The engine on this model operates in a derated mode when the PTO is engaged. This run was done with the field cruise system engaged.

NOTE 2. The manufacturer declares that the average time between active regenerations is 15 hours, while operated in Auto Filter Cleaning Mode, at rated speed, full PTO load, under steady state conditions.

NOTE 3. The 9460RT engine has an electronic control system which provides a vehicle protection system to avoid overloading the drive train. This system provides two different engine power levels. At 2100 rpm the engine produces up to 410 hp when the transmission is in forward gears 1 through 3. The engine produces 460 hp at 2100 rpm for all other gears.

REMARKS: All test results were determined from observed data obtained in accordance with official OECD, SAE and Nebraska test procedures. For the maximum power tests the fuel temperature at the primary fuel filter was maintained at 104°F (40°C). The performance figures on this summary were taken from a test conducted under the OECD Code II test code procedure.

We, the undersigned, certify that this is a true and correct report of official Tractor Test No. **2041**, Nebraska Summary 832, February 20, 2013.

Roger M. Hoy
Director

M.R. Riley
P.J. Jasa
J.D. Luck
Board of Tractor Test Engineers

TRACTOR SOUND LEVEL WITH CAB

dB(A)

At no load in 6th gear	75.8
Transport speed-no load- 18th gear	77.8
Bystander in 18th gear	88.0

TRACKS AND WEIGHT

Track width	30.0 in (762 mm)
Height of Drawbar	21.0 in (535 mm)
Static Weight with operator-	47020 lb(21328 kg)

Tested Without Ballast

DRAWBAR PERFORMANCE
(Unballasted at 1800 RPM)
MAXIMUM POWER IN SELECTED GEARS

Power Hp (kW)	Drawbar pull lbs (kN)	Speed mph (km/h)	Crank- shaft speed rpm	Slip %	Fuel Consumption lb/hp.hr (kg/kW.h)	Hp.hr/gal (kW.h/l)	Temp. °F(°C) cool- ing med	Air dry bulb	Barom. inch Hg (kPa)
287.54 (214.41)	48344 (215.04)	2.23 (3.59)	2067	9.4	0.541 (0.329)	13.04 (2.57)	188 (87)	56 (13)	28.81 (97.56)
316.82 (236.25)	46059 (204.88)	2.58 (4.15)	1934	9.0	0.504 (0.306)	13.99 (2.76)	192 (89)	68 (20)	28.77 (97.43)
333.37 (248.59)	43951 (195.50)	2.85 (4.58)	1893	7.5	0.478 (0.291)	14.73 (2.90)	193 (89)	70 (21)	28.74 (97.33)
375.33 (279.88)	41757 (185.74)	3.38 (5.43)	1973	6.4	0.472 (0.287)	14.95 (2.94)	194 (90)	65 (18)	28.62 (96.92)
389.02 (290.09)	40614 (180.66)	3.60 (5.79)	1895	5.1	0.459 (0.279)	15.37 (3.03)	193 (89)	61 (16)	28.61 (96.88)
391.05 (291.61)	37173 (165.35)	3.95 (6.35)	1837	4.1	0.450 (0.274)	15.65 (3.08)	196 (91)	63 (17)	28.62 (96.92)
396.12 (295.39)	34632 (154.05)	4.29 (6.90)	1800	3.4	0.442 (0.269)	15.97 (3.15)	203 (95)	74 (23)	28.78 (97.46)
400.71 (298.81)	31249 (139.00)	4.81 (7.74)	1800	2.5	0.433 (0.264)	16.27 (3.21)	204 (96)	74 (23)	28.74 (97.33)
399.90 (298.21)	27929 (124.23)	5.37 (8.64)	1800	1.8	0.441 (0.268)	16.00 (3.15)	206 (96)	76 (24)	28.72 (97.26)
400.37 (298.56)	25074 (111.53)	5.99 (9.64)	1800	1.4	0.436 (0.265)	16.16 (3.18)	209 (98)	78 (26)	28.72 (97.26)
398.50 (297.16)	22562 (100.36)	6.62 (10.65)	1799	1.2	0.440 (0.268)	16.03 (3.16)	213 (100)	78 (26)	28.71 (97.22)
402.62 (300.23)	20440 (90.92)	7.39 (11.89)	1800	1.0	0.435 (0.265)	16.21 (3.19)	211 (99)	79 (26)	28.69 (97.16)
395.38 (294.83)	18077 (80.41)	8.20 (13.20)	1800	0.8	0.442 (0.269)	15.94 (3.14)	212 (100)	79 (26)	28.69 (97.16)

Lugging ability in 11th gear

Crankshaft speed rpm	2100	2000	1901	1800	1700	1599	1401	1102
Pull-lbs (kN)	16824 (74.83)	19535 (86.90)	21285 (94.68)	22560 (100.35)	23541 (104.72)	24331 (108.23)	24215 (107.71)	22106 (98.33)
Increase in pull%	0	16	26	34	40	44	44	31
Power-Hp (kW)	348.64 (259.98)	384.48 (286.71)	398.67 (297.29)	399.68 (298.04)	393.07 (293.11)	381.71 (284.64)	332.79 (248.16)	239.45 (178.56)
Speed-mpH (km/h)	7.78 (12.51)	7.38 (11.88)	7.02 (11.30)	6.64 (10.69)	6.26 (10.07)	5.88 (9.46)	5.15 (8.29)	4.06 (6.53)
Slip %	0.7	0.9	1.0	1.1	1.2	1.3	1.3	1.1

HYDRAULIC PERFORMANCE

CATEGORY: 4N/4

Quick Attach: yes

OECD Static test

Maximum force exerted through whole range:

<u>Category 4N</u>	<u>lift cylinders</u>
15583 lbs(69.3 kN) (1 x 90 mm and 1x100 mm)	
21194 lbs(94.3 kN) (2 x 110 mm)	

<u>Category 4</u>	
15642 lbs(69.6 kN) (1 x 90 mm and 1x100 mm)	
21147 lbs(94.1 kN) (2 x 110 mm)	

<u>High flow pump</u>	<u>Base pump</u>
<u>three outlet sets combined</u>	

2917 psi (201 bar)	2959 psi (204 bar)
--------------------	--------------------

i) Sustained pressure at compensator cutoff:

ii) Pump delivery rate at minimum pressure and rated engine speed:

53.9 GPM(203.9 l/min)	32.3 GPM (122.1 l/min)
86.2 GPM (326.0 l/min)	

iii) Pump delivery rate at maximum

hydraulic power:

53.1 GPM(200.9 l/min)	31.8 GPM(120.5 l/min)
-----------------------	-----------------------

Delivery pressure:

2569 psi (177 bar)	2772 psi (191 bar)
--------------------	--------------------

Power:

79.5 HP (59.3 kW)	51.5 HP (38.4 kW)
-------------------	-------------------

i) Sustained pressure at compensator cutoff:

2913 psi (201 bar)	2957 psi (204 bar)
--------------------	--------------------

ii) Pump delivery rate at minimum pressure and rated engine speed:

37.0 GPM(139.9 l/min)	32.1 GPM(121.4 l/min)
-----------------------	-----------------------

iii) Pump delivery rate at maximum

hydraulic power:

35.1 GPM(133.0 l/min)	32.3 GPM(122.1 l/min)
-----------------------	-----------------------

Delivery pressure:

2212 psi (153 bar)	2387 psi (165 bar)
--------------------	--------------------

Power:

45.3 HP (33.8 kW)	44.9 HP (33.5 kW)
-------------------	-------------------

HITCH DIMENSIONS AS TESTED—NO LOAD

	<u>Category 4N</u>		<u>Category 4</u>	
	<u>inch</u>	<u>mm</u>	<u>inch</u>	<u>mm</u>

A	31.5	800	30.7	780
B	19.7	500	19.7	500
C	31.9	810	31.9	810
D	30.4	772	30.4	772
E	13.2	335	13.2	335
F	13.8	350	13.8	350
G	37.6	955	37.6	955
H	0.8	19	0.8	19
I	23.1	586	23.1	586
J	23.8	605	23.8	605
K	30.9	785	30.9	785
L	57.0	1447	57.0	1447
*L'	62.2	1580	62.4	1584
M	32.2	818	32.4	822
N	45.5	1155	45.6	1159
O	9.0	230	9.0	230
P	50.8	1290	50.8	1291
Q	38.5	978	38.6	980
R	50.6	1285	50.4	1280

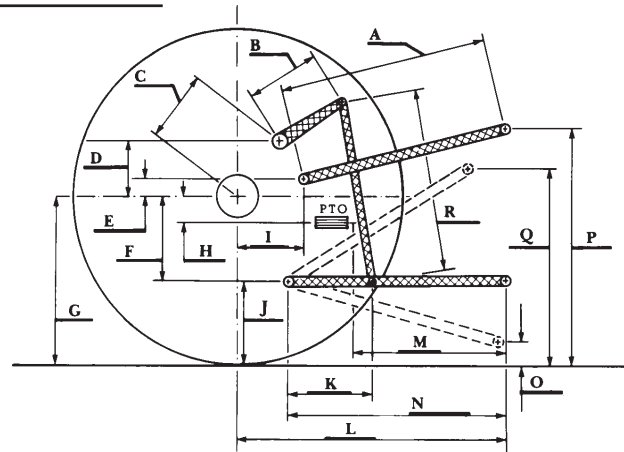

JOHN DEERE 9460RT DIESEL