

NEBRASKA TRACTOR TEST 1837B

CASE IH DX 55 DIESEL

ALSO CASE IH FARMALL 55 DIESEL

12 SPEED

POWER TAKE-OFF PERFORMANCE

Power HP (kW)	Crank shaft speed rpm	Gal/hr (l/h)	lb/hp.hr (kg/kW.h)	Hp.hr/gal (kW.h/l)	Mean Atmospheric Conditions
---------------------	--------------------------------	-----------------	-----------------------	-----------------------	--------------------------------

MAXIMUM POWER AND FUEL CONSUMPTION

Rated Engine Speed—(PTO speed—589 rpm)					
48.01 (35.80)	2700	3.95 (14.93)	0.577 (0.351)	12.17 (2.40)	
Standard Power Take-off Speed(540 rpm)					
47.80 (35.65)	2475	3.66 (13.87)	0.538 (0.327)	13.05 (2.57)	

VARYING POWER AND FUEL CONSUMPTION

48.01 (35.80)	2700	3.95 (14.93)	0.577 (0.351)	12.17 (2.40)	Air temperature
42.46 (31.66)	2801	3.50 (13.26)	0.579 (0.352)	12.12 (2.39)	75°F (24°C)
32.17 (23.99)	2841	2.82 (10.68)	0.616 (0.374)	11.41 (2.25)	Relative humidity
21.75 (16.22)	2871	2.26 (8.57)	0.731 (0.445)	9.61 (1.89)	34%
10.88 (8.11)	2913	1.75 (6.63)	1.130 (0.688)	6.21 (1.22)	Barometer
0.61 (0.46)	2938	1.37 (5.18)	15.732 (9.569)	0.45 (0.09)	28.84"Hg (97.66 kPa)

Maximum Torque 122 lb.-ft. (165 Nm) at 1657 rpm
 Maximum Torque Rise - 30.6%
 Torque rise at 2203 rpm - 20%

TRACTOR SOUND LEVEL WITHOUT CAB

	Front Wheel Drive	
	Disengaged dB(A)	Engaged dB(A)
At no load in 7th (M3) gear	89.0	89.0
Bystander	--	--

TIRES AND WEIGHT

Rear Tires—No., size, ply & psi (kPa)
Front Tires—No., size, ply & psi (kPa)
Height of Drawbar
Static Weight with operator—Rear
 — Front
 — Total

Tested Without Ballast

Two 18.4-24; 8:12 (85)
 Two 12-16.5; 8:12 (85)
 17.0 in (430 mm)
 3035 lb (1377 kg)
 1825 lb (828 kg)
 4860 lb (2205 kg)

Location of Test: Nebraska Tractor Test Laboratory, University of Nebraska, Lincoln Nebraska 68583-0832

Dates of Test: April 29-30, 2004

Manufacturer: CNH America LLC, 700 State Street, Racine, Wi. 53404

FUEL, OIL and TIME: Fuel No. 2 Diesel Specific gravity converted to 60°/60° F (15°/15°C) 0.8432 Fuel weight 7.021 lbs/gal (0.841 kg/l) Oil SAE 15W40 API service classification CF-4/SG Transmission and hydraulic lubricant Case IH Hytran ultra fluid Front axle lubricant Case IH Hytran ultra fluid Total time engine was operated 11.0 hours

ENGINE: Make ISM Diesel **Type** four cylinder vertical with turbocharger **Serial No.** 27999 **Crankshaft** lengthwise **Rated engine speed** 2700 **Bore and stroke** 3.307" x 3.937" (84.0 mm x 100.0 mm) **Compression ratio** 22.4 to 1 **Displacement** 135 cu in (2216 ml) **Starting system** 12 volt **Lubrication** pressure **Air cleaner** two paper elements **Oil filter** one full flow cartridge **Oil cooler** engine coolant heat exchanger for crankcase oil, radiator for hydraulic and transmission oil **Fuel filter** one paper element **Muffler** underhood **Exhaust** horizontal **Cooling medium temperature control** one thermostat

ENGINE OPERATING PARAMETERS: Fuel rate: 25.5 - 28.0 lb/h (11.6 - 12.7 kg/h) **High idle:** 2850 - 2950 rpm **Turbo boost:** nominal 8.0 - 10.1 psi (55 - 70 kPa) as measured 9.4 psi (65 kPa)

CHASSIS: Type front wheel assist **Serial No.** HX10016 **Tread width** rear 52.8" (1341 mm) to 76.3" (1939 mm) front 56.4" (1432 mm) **Wheelbase** 74.8" (1900 mm) **Hydraulic control system** direct engine drive **Transmission** selective gear fixed ratio **Nominal travel speeds mph (km/h)** first 1.16 (1.86) second 1.56 (2.51) third 2.04 (3.29) fourth 2.62 (4.22) fifth 2.90 (4.67) sixth 3.93 (6.32) seventh 5.15 (8.28) eighth 6.61 (10.63) ninth 8.17 (13.15) tenth 11.06 (17.80) eleventh 14.48 (23.30) twelfth 18.59 (29.91) reverse 1.17 (1.88), 1.58 (2.55), 2.07 (3.33), 2.66 (4.28), 2.94 (4.73), 3.98 (6.41), 5.21 (8.39), 6.69 (10.77), 8.28 (13.32), 11.21 (18.04), 14.68 (23.62), 18.83 (30.31) **Clutch** single dry disc operated by foot pedal **Brakes** single wet disc operated by two foot pedals which can be locked together **Steering** hydrostatic **Power take-off** 540 rpm at 2475 engine rpm **Unladen tractor mass** 4685 lb (2125 kg)

HYDRAULIC PERFORMANCE

CATEGORY: I, II

Quick Attach: None

OECD Static test

Maximum force exerted through whole range:	4028 lbs	(17.9 kN) Category I
	3254 lbs	(14.5 kN) Category II
i) Sustained pressure of the open relief valve:	2550 psi	(176 bar)
ii) Pump delivery rate at minimum pressure and rated engine speed:	10.9 GPM	(41.3 l/min)
iii) Pump delivery rate at maximum hydraulic power:	10.7 GPM	(40.5 l/min)
Delivery pressure:	1965 psi	(135 bar)
Power:	12.3 HP	(9.1 kW)

THREE POINT HITCH PERFORMANCE(SAE Static test)

Observed maximum pressure psi.(bar)	2520(174)
Location:	hydraulic manifold
Hydraulic oil temperature: °F(°C)	145(63)
Location:	pump inlet
Category:	II
Quick attach:	none

Category II

System pressure 2320 psi (160 Bar)

Hitch point distance to ground level in.(mm)	7.3(184)	14.4(364)	21.3(540)	28.3(718)	35.3(896)
Lift force on frame lb	4409	4558	4354	4073	3849
" " " " " " (kN)	(19.6)	(20.3)	(19.4)	(18.1)	(17.1)

REPAIRS AND ADJUSTMENTS: The fuel tank was found to be leaking following the PTO tests.

Note: Report reprinted, supplemental for Case IH Farmall 55 Diesel, May 2009.

REMARKS: All test results were determined from observed data obtained in accordance with official OECD, SAE and Nebraska test procedures. This tractor did not meet manufacturer's claim of 11.6 GPM (43.9 lpm) hydraulic flow. For the maximum power tests, the fuel temperature at the injection pump inlet was maintained at 104°F (40°C).

We, the undersigned, certify that this is a true and correct report of official Tractor Test No. **1837B**, May 1, 2009.

Roger M. Hoy
Director

M.F. Kocher
V.I. Adamchuk
J.A. Smith
Board of Tractor Test Engineers

	Category I		Category II	
	inch	mm	inch	mm
A	26.3	667	25.4	644
B	11.8	300	11.8	300
C	13.5	344	13.5	344
D	13.5	342	13.5	342
E	12.1	307	12.1	307
F	5.2	132	5.2	132
G	26.0	660	26.0	660
H	0.5	13	0.5	13
I	8.8	223	8.8	223
J	20.8	528	20.8	528
K	19.3	490	19.3	490
L	34.6	879	34.6	879
M	22.9	582	22.9	582
N	31.5	800	31.5	800
O	7.3	184	7.3	184
P	38.8	986	39.8	1011
Q	31.6	803	31.5	800
R	24.1	613	24.1	613

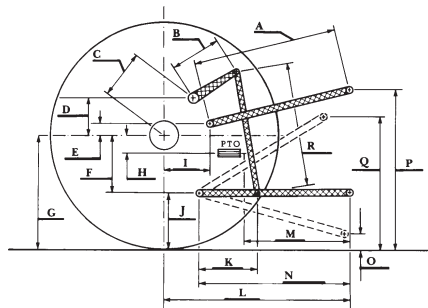

HITCH DIMENSIONS AS TESTED - NO LOAD



Case IH Farmall 55 Diesel