

NEBRASKA TRACTOR TEST 1767

AGCO ALLIS 8745 DIESEL

12 SPEED

POWER TAKE-OFF PERFORMANCE

Power HP (kW)	Crank shaft speed rpm	Gal/hr (l/h)	lb/hp.hr (kg/kW.h)	Hp.hr/gal (kW.h/l)	Mean Atmospheric Conditions
MAXIMUM POWER AND FUEL CONSUMPTION					
Rated Engine Speed (PTO speed 1100 rpm)					
70.53 (52.60)	2200	4.53 (17.13)	0.453 (0.276)	15.59 (3.07)	
Standard Power Take-off Speed - (1000 rpm)					
75.34 (56.18)	2000	4.44 (16.79)	0.416 (0.253)	16.98 (3.35)	
Maximum Power (2 hours)					
76.40 (56.97)	1900	4.39 (16.62)	0.406 (0.247)	17.41 (3.43)	

VARYING POWER AND FUEL CONSUMPTION

70.53 (52.60)	2200	4.53 (17.13)	0.453 (0.276)	15.59 (3.07)	Air temperature
61.86 (46.13)	2266	4.29 (16.23)	0.490 (0.298)	14.43 (2.84)	78°F (26°C)
46.45 (34.64)	2297	3.56 (13.49)	0.543 (0.330)	13.03 (2.57)	Relative humidity
31.50 (23.49)	2322	3.01 (11.41)	0.676 (0.411)	10.45 (2.06)	43%
16.21 (12.09)	2349	2.34 (8.84)	1.018 (0.619)	6.94 (1.37)	Barometer
1.13 (0.84)	2370	1.70 (6.43)	10.637 (6.470)	0.66 (0.13)	28.93"Hg (97.97kPa)

Maximum Torque 240 lb.-ft. (326 Nm) at 1200 rpm
 Maximum Torque Rise - 42.8%
 Torque rise at 1800 rpm - 29%

TRACTOR SOUND LEVEL WITH CAB

At no load in 6th(2M) gear	dB(A)
Bystander	81.5

TIRES AND WEIGHT

Rear Tires No., size, ply & psi (kPa)
Front Tires No., size, ply & psi (kPa)
Height of Drawbar
Static Weight with operator Rear
 Front
 Total

Tested Without Ballast

Two 18.4R30; **, 16 (110)
 Two 9.5L-15; 6; 32 (220)
 16.0 in (405 mm)
 4905 lb (2225 kg)
 3065 lb (1390 kg)
 7970 lb (3615 kg)

Location of Test: Nebraska Tractor Test Laboratory, University of Nebraska, Lincoln Nebraska 68583-0832

Dates of Test: March 14-17, 2000

Manufacturer: AGCO Corporation, Duluth Georgia 30096

FUEL, OIL and TIME: Fuel No. 2 Diesel Specific gravity converted to 60°/60° F (15°/15°C) 0.8487 Fuel weight 7.087 lbs/gal (0.847 kg/l) Oil SAE 15W-40 API service classification CE/CF-4 Transmission and hydraulic lubricant AGCO Power Fluid 821 XL fluid Total time engine was operated 12.5 hours

ENGINE: Make Sisu Diesel **Type** four cylinder vertical with turbocharger **Serial No.** H03172 **Crankshaft** lengthwise **Rated engine speed** 2200 **Bore and stroke** 4.252" x 4.724" (108.0 mm x 120.0 mm) **Compression ratio** 16.5 to 1 **Displacement** 268 cu in (4400 ml) **Starting system** 12 volt **Lubrication** pressure **Air cleaner** one paper element and one polyester felt element **Oil filter** one full flow cartridge **Fuel filter** one paper element and water separator **Muffler** underhood **Exhaust** vertical **Cooling medium temperature control** one thermostat

ENGINE OPERATING PARAMETERS: Fuel rate: 31.7 - 35.3 lb/h (14.4 - 16.0 kg/h) **High idle:** 2350 - 2400 rpm **Turbo boost:** nominal 10.9 - 12.8 psi (75 - 88 kPa) as measured 11.3 psi (78 kPa)

CHASSIS: Type standard **Serial No.** G15038 **Tread width** rear 56.1" (1425 mm) to 83.8" (2130 mm) front 54.0" (1372 mm) to 78.0" (1981 mm) **Wheelbase** 98.8" (2510 mm) **Hydraulic control system** direct engine drive **Transmission** selective gear fixed ratio **Nominal travel speeds mph (km/h)** first 1.44 (2.32) second 1.88 (3.03) third 2.47 (3.98) fourth 3.24 (5.21) fifth 4.06 (6.54) sixth 5.31 (8.55) seventh 6.97 (11.22) eighth 9.13 (14.69) ninth 10.97 (17.66) tenth 14.34 (23.08) eleventh 18.82 (30.29) twelfth 24.65 (39.67) reverse 1.63 (2.62), 2.13(3.43), 2.80(4.50), 3.60(5.80), 4.60 (7.40), 6.00(9.66), 7.88(12.68), 10.32(16.61), 12.41(19.97), 18.08(29.09), 21.28(34.25), 27.87(44.85) **Clutch** multiple wet disc operated by foot pedal **Brakes** single wet disc hydraulically operated by two foot pedals which can be locked together **Steering** hydrostatic **Power take-off** 540 rpm at 1902 engine rpm or 1000 rpm at 2000 engine rpm **Unladen tractor mass** 7795 lb (3536 kg)

THREE POINT HITCH PERFORMANCE (OECD Static Test)

CATEGORY: II

Quick Attach: None

Maximum Force Exerted Through Whole Range:	3348 lbs (14.9 kN)	High lift Option 5733 lbs (25.5 kN)
i) Opening pressure of relief valve:	NA	Combined flow
Sustained pressure of the open relief valve:	2980 psi (205 bar)	3040 psi (210 bar)
ii) Pump delivery rate at minimum pressure and rated engine speed:	10.1 GPM (38.2 l/min)	17.5 GPM (66.2 l/min)
iii) Pump delivery rate at maximum hydraulic power:	7.6 GPM (28.8 l/min)	14.5 GPM (54.9 l/min)
Delivery pressure:	2750 psi (190 bar)	2680 psi (185 bar)
Power:	12.2 HP (9.1 kW)	22.7 HP (16.9 kW)

THREE POINT HITCH PERFORMANCE

Observed Maximum Pressure psi. (bar)	3320 (229)
Location:	lift cylinder
Hydraulic oil temperature: °F (°C)	158 (70)
Location:	hydraulic sump
Category:	II
Quick attach:	none

SAE Static Test System pressure 2990 psi (206 Bar)

Hitch point distance to ground level in. (mm)	9.4 (239)	14.9 (378)	21.9 (556)	28.9 (734)	37.4 (950)
Lift force on frame lb	4113	4500	4631	4613	4743
" " " " " " (kN)	(18.3)	(20.0)	(20.6)	(20.5)	(21.1)

High lift Option

SAE Static Test System pressure 2990 psi (206 Bar)

Hitch point distance to ground level in. (mm)	7.7 (196)	14.7 (373)	21.7 (551)	28.7 (729)	35.7 (907)
Lift force on frame lb	6894	7421	7565	7488	7425
" " " " " " (kN)	(30.7)	(33.0)	(33.7)	(33.3)	(33.0)

	High lift option			
	inch	mm	inch	mm
A	31.0	788	34.0	864
B	12.2	310	12.2	310
C	15.1	384	15.1	384
D	9.4	240	9.4	240
E	7.6	192	7.6	192
F	8.3	210	11.0	280
G	31.3	795	31.3	795
H	1.3	32	1.3	32
I	5.7	145	5.7	145
J	23.0	585	20.3	515
K	26.3	667	24.5	622
L	38.3	972	41.3	1048
M	21.8	552	24.8	629
N	39.0	991	42.0	1067
O	7.9	200	7.9	200
P	47.0	1195	44.3	1125
Q	33.9	860	33.1	841
R	31.6	802	32.1	815

HITCH DIMENSIONS AS TESTED - NO LOAD

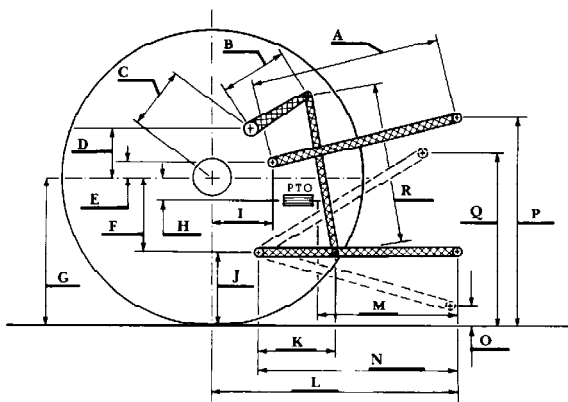

REPAIRS AND ADJUSTMENTS: No repairs or adjustments

REMARKS: All test results were determined from observed data obtained in accordance with official OECD, SAE and Nebraska test procedures. This tractor did not meet manufacturers claim of 17.9 GPM (67 l/min) hydraulic flow. For the maximum power tests, the fuel temperature at the injection pump was maintained at 141°F (61°C).

We, the undersigned, certify that this is a true and correct report of official Tractor Test No. 1767, March 29, 2000.

David L. Morgan
Assistant Director

L. L. Bashford
M. F. Kocher
R. D. Grisso Jr.
Board of Tractor Test Engineers



AGCO Allis 8745 Diesel