

# NEBRASKA TRACTOR TEST 1762

## WHITE 6510 DIESEL

### 12 SPEED

#### POWER TAKE-OFF PERFORMANCE

Power HP (kW)	Crank shaft speed rpm	Gal/hr (l/h)	lb/hp.hr (kg/kW.h)	Hp.hr/gal (kW.h/l)	Mean Atmospheric Conditions
<b>MAXIMUM POWER AND FUEL CONSUMPTION</b>					
<b>Rated Engine Speed (PTO speed 1100 rpm)</b>					
85.40 (63.68)	2200	5.56 (21.05)	0.461 (0.281)	15.36 (3.03)	
<b>Standard Power Take-off Speed - (1000 rpm)</b>					
87.86 (65.52)	2000	5.36 (20.30)	0.432 (0.263)	16.39 (3.23)	
<b>Maximum Power (2 hours)</b>					
88.01 (65.63)	1900	5.24 (19.83)	0.422 (0.257)	16.80 (3.31)	

#### VARYING POWER AND FUEL CONSUMPTION

85.40 (63.68)	2200	5.56 (21.05)	0.461 (0.281)	15.36 (3.03)	Air temperature
75.25 (56.12)	2278	5.08 (19.23)	0.478 (0.291)	14.81 (2.92)	76°F (24°C)
56.88 (42.42)	2316	4.36 (16.50)	0.543 (0.330)	13.05 (2.57)	Relative humidity
38.69 (28.85)	2354	3.47 (13.14)	0.636 (0.387)	11.15 (2.20)	48%
19.34 (14.42)	2391	2.58 (9.77)	0.946 (0.576)	7.49 (1.48)	Barometer
1.73 (1.29)	2417	1.78 (6.73)	7.298 (4.439)	1.02 (0.20)	29.04" Hg (98.34 kPa)

Maximum Torque 275 lb.-ft. (372 Nm) at 1499 rpm  
 Maximum Torque Rise - 34.6%  
 Torque rise at 1802 rpm - 24%

#### TRACTOR SOUND LEVEL WITH CAB

	dB(A)
At no load in 6th(2M) gear	80.1
Bystander	--

#### TIRES AND WEIGHT

**Rear Tires** No., size, ply & psi (kPa)  
**Front Tires** No., size, ply & psi (kPa)  
**Height of Drawbar**  
**Static Weight with operator** Rear  
 Front  
 Total

#### Tested Without Ballast

Two 16.9R38; \*\*, 16 (110)  
 Two 11.00-16; 8; 32 (220)  
 16.0 in (405 mm)  
 5410 lb (2454 kg)  
 3205 lb (1454 kg)  
 8615 lb (3908 kg)

**Location of Test:** Nebraska Tractor Test Laboratory, University of Nebraska, Lincoln Nebraska 68583-0832

**Dates of Test:** September 14-23, 1999

**Manufacturer:** AGCO Corporation, Duluth Georgia 30096

**FUEL, OIL and TIME:** Fuel No. 2 Diesel Specific gravity converted to 60°/60° F (15°/15°C) 0.8512 Fuel weight 7.087 lbs/gal (0.849 kg/l) Oil SAE 10W-30 API service classification CE/CF-4 Transmission and hydraulic lubricant AGCO Power Fluid 821 XL fluid Total time engine was operated 13.0 hours

**ENGINE: Make** Cummins Diesel **Type** four cylinder vertical with turbocharger **Serial No.** 21319320 **Crankshaft** lengthwise **Rated engine speed** 2200 **Bore and stroke** 4.016" x 4.72" (102.0 mm x 120.0 mm) **Compression ratio** 17.4 to 1 **Displacement** 239 cu in (3920 ml) **Starting system** 12 volt **Lubrication** pressure **Air cleaner** one paper element and one polyester felt element **Oil filter** one full flow cartridge **Oil cooler** engine coolant heat exchanger for crankcase oil, radiator for transmission and hydraulic oil **Fuel filter** one paper element and water separator **Muffler** underhood **Exhaust** vertical **Cooling medium temperature control** one thermostat

**ENGINE OPERATING PARAMETERS: Fuel rate:** 37.0 - 41.0 lb/h (16.8 - 18.6 kg/h) **High idle:** 2350 - 2450 rpm **Turbo boost:** nominal 23.2 - 24.9 psi (160 - 172 kPa) as measured 24.0 psi (165 kPa)

**CHASSIS: Type** standard **Serial No.** G26067 **Tread width** rear 60.0" (1525 mm) to 88.0" (2235 mm) front 54.0" (1372 mm) to 78.0" (1981 mm) **Wheelbase** 92.4" (2438 mm) **Hydraulic control system** direct engine drive **Transmission** selective gear fixed ratio **Nominal travel speeds mph (km/h)** first 1.37 (2.21) second 1.79 (2.88) third 2.39 (3.84) fourth 3.11 (5.00) fifth 3.94 (6.34) sixth 5.14 (8.27) seventh 6.75 (10.86) eighth 8.78 (14.13) ninth 10.57 (17.01) tenth 13.86 (22.30) eleventh 18.16 (29.22) twelfth 23.77 (38.26) reverse 1.55 (2.50), 2.03 (3.27), 2.68 (4.32), 3.52 (5.67), 4.42 (7.11), 5.79 (9.32), 7.59 (12.21), 9.97 (16.05), 11.94 (19.22), 15.65 (25.18), 20.54 (33.06), 26.88 (43.25) **Clutch** multiple wet disc operated by foot pedal **Brakes** single wet disc hydraulically operated by two foot pedals which can be locked together **Steering** hydrostatic **Power take-off** 540 rpm at 1902 engine rpm or 1000 rpm at 2000 engine rpm **Unladen tractor mass** 8450 lb (3833 kg)

### THREE POINT HITCH PERFORMANCE (OECD Static Test)

CATEGORY: II

Quick Attach: None

			High lift Option
Maximum Force Exerted Through Whole Range:	3348 lbs (14.9 kN)		5733 lbs (25.5 kN)
i) Opening pressure of relief valve:	NA		Combined flow
Sustained pressure of the open relief valve:	3070 psi (212 bar)		3060 psi (211 bar)
ii) Pump delivery rate at minimum pressure and rated engine speed:	10.8 GPM (40.9 l/min)		18.4 GPM (69.7 l/min)
iii) Pump delivery rate at maximum hydraulic power:	8.7 GPM (32.9 l/min)		16.2 GPM (61.3 l/min)
Delivery pressure:	2760 psi (190 bar)		2760 psi (190 bar)
Power:	14.0 HP (10.4 kW)		26.1 HP (19.5 kW)

### THREE POINT HITCH PERFORMANCE

Observed Maximum Pressure psi. (bar)	3320 (229)
Location:	lift cylinder
Hydraulic oil temperature: °F (°C)	158 (70)
Location:	hydraulic sump
Category:	II
Quick attach:	none

#### SAE Static Test System pressure 2990 psi (206 Bar)

Hitch point distance to ground level in. (mm)	9.4 (239)	14.9 (378)	21.9 (556)	28.9 (734)	37.4 (950)
Lift force on frame lb	4113	4500	4631	4613	4743
" " " " " " (kN)	(18.3)	(20.0)	(20.6)	(20.5)	(21.1)

#### High lift Option

##### SAE Static Test System pressure 2990 psi (206 Bar)

Hitch point distance to ground level in. (mm)	7.7 (196)	14.7 (373)	21.7 (551)	28.7 (729)	35.7 (907)
Lift force on frame lb	6894	7421	7565	7488	7425
" " " " " " (kN)	(30.7)	(33.0)	(33.7)	(33.3)	(33.0)

	High lift option			
	inch	mm	inch	mm
A	31.0	788	34.0	864
B	12.2	310	12.2	310
C	15.1	384	15.1	384
D	9.4	240	9.4	240
E	7.6	192	7.6	192
F	8.3	210	11.0	280
G	31.3	795	31.3	795
H	1.3	32	1.3	32
I	5.7	145	5.7	145
J	23.0	585	20.3	515
K	26.3	667	24.5	622
L	38.3	972	41.3	1048
M	21.8	552	24.8	629
N	39.0	991	42.0	1067
O	7.9	200	7.9	200
P	47.0	1195	44.3	1125
Q	33.9	860	33.1	841
R	31.6	802	32.1	815

#### HITCH DIMENSIONS AS TESTED - NO LOAD

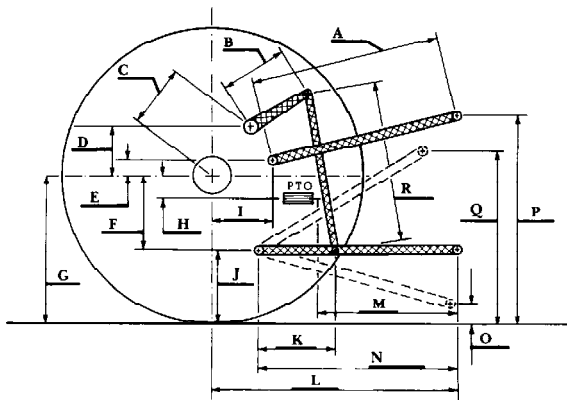

Agricultural Research Division  
 Institute of Agriculture and Natural Resources  
 University of Nebraska Lincoln  
 Darrell Nelson, Dean and Director

**REPAIRS AND ADJUSTMENTS:** No repairs or adjustments

**REMARKS:** All test results were determined from observed data obtained in accordance with official OECD, SAE and Nebraska test procedures. For the maximum power tests, the fuel temperature at the injection pump was maintained at 153°F (67°C).

We, the undersigned, certify that this is a true and correct report of official Tractor Test No. 1762, November 18, 1999.

DAVID L. MORGAN  
 Assistant Director

L. L. BASHFORD  
 M.F. KOCHER  
 R.D. GRISSO Jr.  
 Board of Tractor Test Engineers



White 6510 Diesel