

NEBRASKA OECD TRACTOR TEST 1844—SUMMARY 448

JOHN DEERE 9620 DIESEL

18 SPEED

Location of Test: Nebraska Tractor Test Laboratory, University of Nebraska, Lincoln, Nebraska 68583-0832

Dates of Test: November 2-18, 2004

Manufacturer: John Deere Tractor Works, 3500 East Donald St., P.O. Box 270, Waterloo Ia, 50704-0270

FUEL, OIL and TIME: Fuel No. 2 Diesel Specific gravity converted to 60°/60°F (15°/15°C) 0.8420 Fuel weight 7.011 lbs/gal (0.840 kg/l) Oil SAE 15W-40 API service classification CH-4 Transmission, hydraulic and final drive lubricant John Deere Hy-Gard fluid Total time engine was operated: 33.5 hours

ENGINE: Make John Deere Diesel **Type** six cylinder vertical with turbocharger and air to air aftercooler **Serial No.** *RG6125H041870* **Crankshaft** lengthwise **Rated engine speed** 2100 **Bore and stroke** 5.00" x 6.50" (127.0 mm x 165.0 mm) **Compression ratio** 14.7 to 1 **Displacement** 765 cu in (12536 ml) **Starting system** 12 volt **Lubrication** pressure **Air cleaner** two paper elements and aspirator **Oil filter** one full flow cartridge **Oil cooler** engine coolant heat exchanger for crankcase oil, separate radiators for hydraulic and transmission oil, radiator for front and rear axle oil **Fuel filter** one paper element, one paper cartridge and water separator **Muffler** vertical **Cooling medium temperature control** 2 thermostats and variable speed fan

ENGINE OPERATING PARAMETERS: Fuel rate: (375 engine hp) 128.5 - 141.7 lb/h (58.3-64.3 kg/h), (400 engine hp) 134.4 - 148.2 lb/h (61.0-67.2 kg/h), (425 engine hp) 139.6 - 153.9 lb/h (63.3-69.8 kg/h), (450 engine hp) 149.1 - 164.4 lb/h (67.6-74.6 kg/h), (475 engine hp) 158.4 - 173.4 lb/h (71.8-78.7 kg/h), (500 engine hp) 167.6 - 182.3 lb/h (76.0-82.7 kg/h) **High idle:** 2205 - 2255 rpm **Turbo boost:** (375 engine hp) nominal 21.8 - 25.4 psi (150 - 175 kPa) as measured 23.5 psi (162 kPa)

CHASSIS: Type four wheel drive with triples **Serial No.** *RW9620P021947* **Tread width** rear 57.5" (1460 mm) to 163.8" (4160 mm) front 57.5" (1460 mm) to 163.8" (4160 mm) **Wheelbase** 137.8" (3500 mm) **Hydraulic control system** direct engine drive **Transmission** selective gear fixed ratio with full range operator controlled power shift **Nominal travel speeds mph (km/h)** first 2.31 (3.72) second 2.85 (4.58) third 3.15 (5.07) fourth 3.52 (5.66) fifth 3.88 (6.24) sixth 4.33 (6.97) seventh 4.80 (7.72) eighth 5.36 (8.62) ninth 5.90 (9.50) tenth 6.59 (10.60) eleventh 7.30 (11.74) twelfth 8.06 (12.97) thirteenth 8.98 (14.45) fourteenth 9.92 (15.97) fifteenth 12.27 (19.74) sixteenth 15.09 (24.29) seventeenth 18.65 (30.02) eighteenth 22.96 (36.95) reverse 2.31 (3.72), 3.15 (5.07), 3.52 (5.66), 4.80 (7.72), 5.36 (8.62), 7.30 (11.74)

POWER TAKE-OFF PERFORMANCE

Power HP (kW)	Crank shaft speed rpm	Gal/ltr (l/h)	lb/hp.hr (kg/kW.h)	Hp.hr/gal (kW.h/l)	Mean Atmospheric Conditions
MAXIMUM POWER AND FUEL CONSUMPTION					
Rated Engine Speed—(PTO speed—1109 rpm)					
333.15 (248.43)	2100	18.76 (71.03)	0.395 (0.240)	17.75 (3.50)	
Standard Power Take-off Speed—(PTO speed—1000 rpm)					
370.67 (276.41)	1894	20.01 (75.76)	0.379 (0.230)	18.52 (3.65)	
Maximum Power (2 hours)					
376.70 (280.91)	1700	19.65 (74.37)	0.366 (0.222)	19.17 (3.78)	

VARYING POWER AND FUEL CONSUMPTION

333.15 (248.43)	2100	18.76 (71.03)	0.395 (0.240)	17.75 (3.50)	Air temperature
290.55 (216.66)	2156	17.63 (66.73)	0.425 (0.259)	16.48 (3.25)	75°F (24°C)
220.25 (164.24)	2179	14.16 (53.61)	0.451 (0.274)	15.55 (3.06)	Relative humidity
148.23 (110.54)	2200	11.04 (41.79)	0.522 (0.318)	13.43 (2.65)	30%
74.82 (55.79)	2221	7.57 (28.67)	0.710 (0.432)	9.88 (1.95)	Barometer
1.69 (1.26)	2237	4.62 (17.49)	19.212 (11.686)	0.36 (0.07)	29.18" Hg (98.82 kPa)

Maximum Torque - 1238 lb.-ft. (1679 Nm) at 1252 rpm
Maximum Torque Rise - 48.4%
Torque rise at 1700 engine rpm - 39%

DRAWBAR PERFORMANCE (Unballasted) FUEL CONSUMPTION CHARACTERISTICS

Power Hp (kW)	Drawbar pull lbs (kN)	Speed mph (km/h)	Crank-shaft speed rpm	Slip %	Fuel Consumption lb/hp.hr (kg/kW.h)	Hp.hr/gal (kW.h/l)	Temp. °F (°C) cool-ing med	Air dry bulb	Barom. inch Hg (kPa)
Maximum Power—7th Gear									
397.47 (296.39)	31851 (141.68)	4.68 (7.53)	2100	3.10	0.422 (0.257)	16.62 (3.27)	179 (82)	52 (11)	29.17 (98.78)
75% of Pull at Maximum Power—7th Gear									
310.92 (231.86)	23849 (106.08)	4.89 (7.87)	2168	2.12	0.454 (0.276)	15.45 (3.04)	181 (83)	57 (14)	28.92 (97.93)
50% of Pull at Maximum Power—7th Gear									
211.17 (157.47)	15877 (70.62)	4.99 (8.03)	2195	1.21	0.494 (0.301)	14.19 (2.80)	176 (80)	54 (12)	28.94 (98.00)
75% of Pull at Reduced Engine Speed—9th Gear									
311.23 (232.08)	23837 (106.03)	4.90 (7.88)	1763	2.03	0.418 (0.254)	16.76 (3.30)	184 (85)	59 (15)	28.91 (97.90)
50% of Pull at Reduced Engine Speed—9th Gear									
211.77 (157.92)	15895 (70.71)	5.00 (8.04)	1785	1.29	0.443 (0.270)	15.82 (3.12)	181 (83)	60 (16)	28.91 (97.90)

DRAWBAR PERFORMANCE

(Unballasted at 2100 rpm)

MAXIMUM POWER IN SELECTED GEARS

Power Hp (kW)	Drawbar pull lbs (kN)	Speed mph (km/h)	Crank- shaft speed rpm	Slip %	Fuel Consumption lb/hp.hr (kg/kW.h)	Temp. °F cool- ing med	Temp. °C Air dry bulb	Barom. inch Hg (kPa)	
2nd Gear									
291.64 (217.48)	40461 (179.98)	2.70 (4.35)	2128	7.01	0.453 (0.275)	15.49 (3.05)	182 (83)	46 (8)	29.00 (98.21)
3rd Gear									
307.79 (229.52)	38295 (170.35)	3.01 (4.85)	2099	5.56	0.431 (0.262)	16.26 (3.20)	183 (84)	47 (8)	28.97 (98.10)
4th Gear									
327.49 (244.21)	36128 (160.71)	3.40 (5.47)	2101	4.29	0.429 (0.261)	16.36 (3.22)	181 (83)	49 (9)	28.95 (98.03)
5th Gear									
353.21 (263.39)	35314 (157.08)	3.75 (6.04)	2100	4.00	0.423 (0.257)	16.58 (3.27)	180 (82)	50 (10)	28.93 (97.97)
6th Gear									
372.02 (277.41)	33114 (147.30)	4.21 (6.78)	2099	3.61	0.424 (0.258)	16.55 (3.26)	181 (83)	52 (11)	28.91 (97.90)
7th Gear									
397.47 (296.39)	31851 (141.68)	4.68 (7.53)	2100	3.10	0.422 (0.257)	16.62 (3.27)	179 (82)	52 (11)	29.17 (98.78)
8th Gear									
420.29 (313.41)	29991 (133.41)	5.26 (8.46)	2104	2.74	0.418 (0.254)	16.79 (3.31)	181 (83)	51 (11)	29.17 (98.78)
9th Gear									
419.05 (312.49)	27046 (120.31)	5.81 (9.35)	2100	2.29	0.418 (0.254)	16.78 (3.31)	182 (84)	52 (11)	29.17 (98.78)
10th Gear									
414.59 (309.16)	23834 (106.02)	6.52 (10.50)	2103	1.87	0.423 (0.257)	16.58 (3.27)	185 (85)	52 (11)	29.17 (98.78)
11th Gear									
415.32 (309.70)	21567 (95.94)	7.22 (11.62)	2097	1.61	0.421 (0.256)	16.67 (3.28)	182 (83)	52 (11)	29.17 (98.78)
12th Gear									
411.31 (306.72)	19260 (85.67)	8.01 (12.89)	2101	1.45	0.426 (0.259)	16.47 (3.24)	183 (84)	48 (9)	29.17 (98.78)

TRACTOR SOUND LEVEL WITH CAB

dB(A)

At no load in 7th gear	73.6
Transport speed - no load - 18th gear	75.6
Bystander in 18th gear	-----

TIRES, BALLAST AND WEIGHT

	With Ballast	Without Ballast
Rear Tires - No., size, ply & psi(kPa)	Six 480/80R46;***;12(85)	Six 480/80R46;***;8(55)
Ballast - Liquid (total)	None	None
- Cast Iron (total)	5885 lb (2669 kg)	None
Front Tires - No., size, ply & psi(kPa)	Six 480/80R46;***;17(115)	Six 480/80R46;***;12(85)
Ballast - Liquid (total)	None	None
- Cast Iron (total)	4885 lb (2216 kg)	None
Height of Drawbar	19.5 in (495 mm)	19.5 in (495 mm)
Static Weight with operator - Rear	22345 lb(10136 kg)	16460 lb (7466 kg)
- Front	27700 lb(12564 kg)	22815 lb(10349 kg)
- Total	50045 lb(22700 kg)	39275 lb(17815 kg)

Clutch wet multiple disc hydraulically actuated by foot pedal **Brakes** wet multiple disc hydraulically actuated foot pedal **Steering** hydrostatic and articulated **Power take-off** 1000 rpm at 1895 engine rpm **Unladen tractor mass** 39100 lb (17735 kg)

REPAIRS AND ADJUSTMENTS: No repairs or adjustments.

NOTE: The 9620 engine has an electronic control system which provides a vehicle protection system to avoid overloading the drive train. This system provides six different engine power levels. At 2100 rpm the engine produces up to 375 hp when the transmission is in forward gears 1 through 3 or when the tractor is being used for stationary PTO operations. At 2100 rpm the engine produces 400 hp when the transmission is in gear 4. At 2100 rpm the engine produces 425 hp when the transmission is in gear 5. At 2100 rpm the engine produces 450 hp when the transmission is in gear 6. At 2100 rpm the engine produces 475 hp when the transmission is in gear 7. At 2100 rpm the engine produces 500 hp in all other applications.

REMARKS: All test results were determined from observed data obtained in accordance with official OECD, SAE and Nebraska test procedures. For the maximum power tests the fuel temperature at the injection pump inlet was maintained at 98°F (37°C). The pull in 1st gear (ballasted tractor), 2nd gear (unballasted tractor) was limited to avoid tractor bouncing. The performance figures on this summary were taken from a test conducted under the OECD Code II test code procedure.

We, the undersigned, certify that this is a true and correct report of official Tractor Test No. **1844**, Nebraska Summary 448, February 4, 2005.

Leonard L. Bashford
Director

M.F. Kocher
V.I. Adamchuk
W.P. Campbell
Board of Tractor Test Engineers

DRAWBAR PERFORMANCE
(Unballasted at 1800 RPM)
MAXIMUM POWER IN SELECTED GEARS

Power Hp (kW)	Drawbar pull lbs (kN)	Speed mph (km/h)	Crank- shaft speed rpm	Slip %	Fuel Consumption lb/hp.hr (kg/kW.h)	Hp.hr/gal (kW.h/l)	Temp. °F(°C) cool- ing med	Air dry bulb	Barom. inch Hg (kPa)
2nd Gear									
292.33 (217.99)	40614 (180.66)	2.70 (4.34)	2123	6.85	0.452 (0.275)	15.53 (3.06)	182 (83)	46 (8)	29.00 (98.21)
3rd Gear									
309.02 (230.43)	39334 (174.97)	2.95 (4.74)	2075	6.13	0.434 (0.264)	16.16 (3.18)	181 (83)	48 (9)	28.96 (98.07)
4th Gear									
339.65 (253.27)	39231 (174.51)	3.25 (5.22)	2041	5.78	0.430 (0.262)	16.29 (3.21)	182 (83)	49 (9)	28.94 (98.00)
5th Gear									
367.82 (274.28)	38954 (173.28)	3.54 (5.70)	2022	6.01	0.426 (0.259)	16.46 (3.24)	183 (84)	51 (11)	28.92 (97.93)
6th Gear									
393.65 (293.54)	38919 (173.12)	3.79 (6.10)	1941	5.96	0.428 (0.261)	16.37 (3.22)	185 (85)	53 (12)	28.90 (97.87)
7th Gear									
428.98 (319.89)	38809 (172.63)	4.15 (6.67)	1908	5.57	0.429 (0.261)	16.32 (3.22)	186 (85)	52 (11)	29.17 (98.78)
8th Gear									
459.88 (342.93)	38339 (170.54)	4.50 (7.24)	1850	5.30	0.430 (0.262)	16.30 (3.21)	188 (86)	51 (11)	29.17 (98.78)
9th Gear									
465.83 (347.37)	35533 (158.06)	4.92 (7.91)	1809	3.94	0.425 (0.259)	16.49 (3.25)	187 (86)	51 (11)	29.17 (98.78)
10th Gear									
468.31 (349.22)	31638 (140.73)	5.55 (8.93)	1809	2.94	0.419 (0.255)	16.73 (3.30)	187 (86)	52 (11)	29.17 (98.78)
11th Gear									
468.86 (349.63)	28489 (126.73)	6.17 (9.93)	1810	2.45	0.418 (0.254)	16.77 (3.30)	188 (87)	52 (11)	29.17 (98.78)
12th Gear									
470.29 (350.70)	25819 (114.85)	6.83 (10.99)	1805	2.09	0.418 (0.254)	16.77 (3.30)	187 (86)	49 (9)	29.17 (98.78)
13th Gear									
464.06 (346.05)	22823 (101.52)	7.62 (12.27)	1803	1.80	0.421 (0.256)	16.67 (3.28)	188 (86)	52 (11)	29.17 (98.78)
14th Gear									
468.66 (349.48)	20808 (92.56)	8.45 (13.59)	1803	1.54	0.415 (0.252)	16.91 (3.33)	187 (86)	52 (11)	29.17 (98.78)

Lugging ability in 12th gear

Crankshaft speed rpm	2101	2003	1904	1805	1703	1605	1499	1102
Pull-lbs (kN)	19260 (85.67)	22021 (97.95)	24060 (107.02)	25819 (114.84)	27250 (121.21)	28245 (125.64)	28332 (126.03)	28162 (125.27)
Increase in pull%	0	14	25	34	41	47	47	46
Power-Hp (kW)	411.31 (306.71)	446.82 (333.20)	463.12 (345.35)	470.29 (350.70)	467.20 (348.39)	455.98 (340.02)	427.08 (318.47)	311.40 (232.21)
Speed-mpH (km/h)	8.01 (12.89)	7.61 (12.25)	7.22 (11.62)	6.83 (10.99)	6.43 (10.35)	6.05 (9.73)	5.65 (9.09)	4.15 (6.68)
Slip %	1.45	1.72	1.95	2.09	2.29	2.41	2.46	2.46

DRAWBAR PERFORMANCE
(Ballasted at 1800 RPM)
MAXIMUM POWER IN SELECTED GEARS

Power Hp (kW)	Drawbar pull lbs (kN)	Speed mph (km/h)	Crank- shaft speed rpm	Slip %	Fuel Consumption lb/hp.hr (kg/kW.h)	Fuel Consumption Hp.hr/gal (kW.h/l)	Temp. °F(°C) cool- ing med	Air dry bulb	Barom. inch Hg (kPa)
1st Gear									
294.77 (219.81)	51197 (227.74)	2.16 (3.47)	2103	8.10	0.449 (0.273)	15.62 (3.08)	183 (84)	42 (6)	29.26 (99.09)
2nd Gear									
321.56 (239.79)	48867 (217.37)	2.47 (3.97)	1937	6.86	0.440 (0.268)	15.92 (3.14)	184 (84)	60 (16)	28.93 (97.97)
3rd Gear									
332.94 (248.28)	47706 (212.21)	2.62 (4.21)	1843	6.22	0.427 (0.260)	16.40 (3.23)	184 (85)	63 (17)	28.92 (97.93)
4th Gear									
354.44 (264.30)	46263 (205.79)	2.87 (4.62)	1802	6.16	0.422 (0.257)	16.60 (3.27)	186 (86)	66 (19)	28.91 (97.90)
5th Gear									
387.22 (288.75)	45817 (203.81)	3.17 (5.10)	1801	5.80	0.420 (0.256)	16.69 (3.29)	189 (87)	68 (20)	28.91 (97.90)
6th Gear									
408.44 (304.57)	42793 (190.35)	3.58 (5.76)	1799	4.49	0.420 (0.255)	16.69 (3.29)	190 (88)	68 (20)	28.90 (97.87)
7th Gear									
437.06 (325.91)	41190 (183.22)	3.98 (6.40)	1800	4.23	0.410 (0.249)	17.11 (3.37)	193 (90)	68 (20)	28.89 (97.83)
8th Gear									
469.27 (349.93)	39393 (175.23)	4.47 (7.19)	1802	3.66	0.409 (0.249)	17.13 (3.37)	195 (91)	68 (20)	28.88 (97.80)
9th Gear									
467.97 (348.97)	35357 (157.28)	4.96 (7.99)	1804	2.96	0.416 (0.253)	16.86 (3.32)	197 (92)	68 (20)	28.88 (97.80)
10th Gear									
468.98 (349.72)	31614 (140.63)	5.56 (8.95)	1800	2.43	0.416 (0.253)	16.87 (3.32)	196 (91)	68 (20)	28.87 (97.77)
11th Gear									
471.09 (351.29)	28534 (126.93)	6.19 (9.96)	1803	2.07	0.415 (0.252)	16.90 (3.33)	198 (92)	68 (20)	28.87 (97.77)
12th Gear									
472.40 (352.27)	25874 (115.10)	6.85 (11.02)	1800	1.78	0.408 (0.248)	17.17 (3.38)	199 (93)	67 (19)	28.86 (97.73)
13th Gear									
466.28 (347.71)	22882 (101.78)	7.64 (12.30)	1797	1.45	0.417 (0.253)	16.83 (3.31)	202 (94)	67 (19)	28.86 (97.73)
14th Gear									
470.16 (350.60)	20821 (92.62)	8.47 (13.63)	1799	1.26	0.416 (0.253)	16.84 (3.32)	200 (93)	67 (19)	28.85 (97.70)

THREE POINT HITCH PERFORMANCE (OECD Static Test)

CATEGORY: III, IV

Quick Attach: yes

Maximum Force Exerted Through Whole Range: 13104 lbs (58.3 kN) (Cat. III hitch)
14382 lbs (64.0 kN) (Cat. IV hitch)

i) Opening pressure of relief valve:	NA	
Sustained pressure at compensator cutoff:	2964 psi (204 bar)	
	<u>Single outlet set</u>	<u>Two outlet sets combined</u>
ii) Pump delivery rate at minimum pressure and rated engine speed:	37.9 GPM (143.5 l/min)	49.7 GPM (188.1 l/min)
iii) Pump delivery rate at maximum hydraulic power:	32.1 GPM (121.5 l/min)	49.7 GPM (188.1 l/min)
Delivery pressure:	2042 psi (141 bar)	2190 psi (151 bar)
Power:	38.2 Hp (28.5 kW)	63.5 HP (47.4 kW)

THREE POINT HITCH PERFORMANCE

Observed Maximum Pressure psi. (bar): 2950 (203)
Location: remote outlet
Hydraulic oil temperature: °F (°C): 147 (64)
Location: hydraulic sump
Category: III, IV
Quick attach: yes

Category III (lift cylinders - 2x90 mm) SAE Static Test—System pressure 2575 psi (177 Bar)

Hitch point distance to ground level in. (mm)	8.0 (203)	16.0 (409)	24.0 (610)	32.0 (813)	40.0 (1016)
Lift force on frame lb	14589	14463	14418	13995	12978
" " " " " " (kN)	(64.9)	(64.3)	(64.1)	(62.3)	(57.7)

ASAE Static Test—System pressure 2775 psi (191 Bar)

Hitch point distance to ground level in. (mm)	8.0 (203)	16.0 (409)	24.0 (610)	32.0 (813)	40.0 (1016)
Lift force on frame lb	15715	15580	15531	15076	13980
" " " " " " (kN)	(69.9)	(69.3)	(69.1)	(67.1)	(62.2)

Category IV (lift cylinders - 1x90 mm & 1x100 mm) SAE Static Test - System pressure 2575 psi (177 Bar)

Hitch point distance to ground level in. (mm)	8.0 (203)	15.2 (386)	22.4 (569)	29.6 (752)	36.8 (935)	43.0 (1092)
Lift force on frame lb	16074	15908	16029	15696	14994	13518
" " " " " " (kN)	(71.5)	(70.8)	(71.3)	(69.8)	(66.7)	(60.1)

ASAE Static Test—System pressure 2775 psi (191 Bar)

Hitch point distance to ground level in. (mm)	8.0 (203)	15.2 (386)	22.4 (569)	29.6 (752)	36.8 (935)	43.0 (1092)
Lift force on frame lb	17199	17020	17208	16851	16152	14562
" " " " " " (kN)	(76.5)	(75.7)	(76.6)	(75.0)	(71.8)	(64.8)

HITCH DIMENSIONS AS TESTED—NO LOAD

	Category III		Category IV	
	inch	mm	inch	mm
A	30.8	780	30.3	770
B	18.6	472	18.6	472
C	26.2	666	26.2	666
D	24.4	620	24.4	620
E	11.3	288	11.3	288
F	13.8	350	13.8	350
G	35.6	905	35.6	905
H	4.8	122	4.8	122
I	22.7	577	22.7	577
J	21.8	555	21.8	555
K	28.8	731	28.3	718
L	55.3	1405	54.5	1384
*L'	61.8	1570	60.5	1537
M	25.4	645	24.6	625
N	44.0	1117	43.2	1097
O	8.0	203	8.0	203
P	48.6	1234	48.6	1234
Q	39.1	993	39.0	991
R	44.8	1137	45.0	1143

*L' to Quick Attach ends

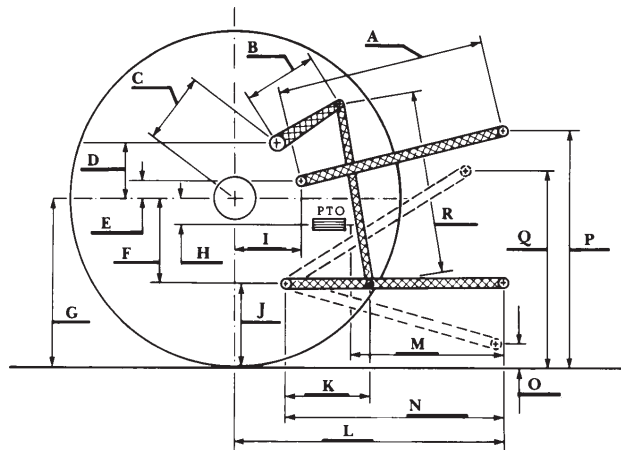

OPTIONAL AG HIGH FLOW SYSTEM

i) Opening pressure of relief valve:	NA
Sustained pressure at compensator cutoff:	2945 psi (203 bar)
	<u>Single outlet set</u> <u>Three outlet sets combined</u>
ii) Pump delivery rate at minimum pressure and rated engine speed:	35.5 GPM (134.4 l/min) 80.9 GPM (306.2 l/min)
iii) Pump delivery rate at maximum hydraulic power:	32.2 GPM (121.9 l/min) 72.3 GPM (273.7 l/min)
Delivery pressure:	1997 psi (138 bar) 2373 psi (164 bar)
Power:	37.5 Hp (28.0 kW) 100.1 Hp (74.6 kW)



JOHN DEERE 9620 DIESEL