

NEBRASKA OECD TRACTOR TEST 1926—SUMMARY 596

JOHN DEERE 9630 DIESEL

18 SPEED

DRAWBAR PERFORMANCE (Unballasted) FUEL CONSUMPTION CHARACTERISTICS

| Power Hp (kW) | Drawbar pull lbs (kN) | Speed mph (km/h) | Crank- shaft speed rpm | Slip % | Fuel Consumption | | Temp. °F (°C) | Barom. inch Hg (kPa) | |
|--|--------------------------------|------------------------|---------------------------------|-----------|-----------------------|-----------------------|---------------------|-------------------------------|------------------|
| | | | | | lb/lp.hr (kg/kW.h) | Hp.hr/gal (kW.h/l) | cool- ing med | Air dry bulb | |
| Maximum Power—8th Gear | | | | | | | | | |
| 427.14 (318.52) | 29610 (131.71) | 5.41 (8.71) | 2098 | 3.1 | 0.453 (0.276) | 15.39 (3.03) | 202 (94) | 68 (20) | 28.69 (97.16) |
| 75% of Pull at Maximum Power—8th Gear | | | | | | | | | |
| 340.31 (253.77) | 22685 (100.91) | 5.63 (9.05) | 2168 | 2.5 | 0.489 (0.297) | 14.27 (2.81) | 204 (95) | 76 (24) | 28.59 (96.82) |
| 50% of Pull at Maximum Power—8th Gear | | | | | | | | | |
| 226.85 (169.16) | 14802 (65.84) | 5.75 (9.25) | 2195 | 1.7 | 0.558 (0.339) | 12.51 (2.46) | 188 (87) | 74 (23) | 28.57 (96.75) |
| 75% of Pull at Reduced Engine Speed—11th Gear | | | | | | | | | |
| 339.35 (253.05) | 22699 (100.97) | 5.61 (9.02) | 1588 | 2.6 | 0.475 (0.289) | 14.70 (2.90) | 201 (94) | 75 (24) | 28.59 (96.82) |
| 50% of Pull at Reduced Engine Speed—11th Gear | | | | | | | | | |
| 226.47 (168.88) | 14795 (65.81) | 5.74 (9.24) | 1609 | 1.6 | 0.523 (0.318) | 13.33 (2.63) | 202 (94) | 74 (23) | 28.56 (96.72) |

Lugging ability in 11th gear

| Crankshaft speed rpm | 2097 | 2004 | 1870 | 1693 | 1601 | 1500 | 1203 | 1099 |
|----------------------|--------------------|--------------------|--------------------|--------------------|--------------------|--------------------|--------------------|--------------------|
| Pull-lbs (kN) | 20994 (93.39) | 24136 (107.36) | 26530 (118.01) | 28930 (128.69) | 30083 (133.82) | 30397 (135.21) | 30654 (136.36) | 29883 (132.93) |
| Increase in pull% | 0 | 15 | 26 | 38 | 43 | 45 | 46 | 42 |
| Power-Hp (kW) | 416.64 (310.69) | 456.32 (340.28) | 464.75 (346.56) | 457.11 (340.86) | 449.07 (334.87) | 424.31 (316.41) | 341.50 (254.66) | 304.79 (227.28) |
| Speed-mpg (km/h) | 7.44 (11.97) | 7.09 (11.41) | 6.57 (10.57) | 5.93 (9.54) | 5.60 (9.01) | 5.23 (8.42) | 4.18 (6.72) | 3.82 (6.16) |
| Slip% | 1.9 | 2.2 | 2.9 | 3.3 | 3.4 | 3.6 | 4.0 | 3.8 |

Location of tests: Nebraska Tractor Test Laboratory, University of Nebraska, Lincoln, Nebraska 68583-0832

Dates of tests: November 4-14, 2008

Manufacturer: John Deere Tractor Works, 3500 East Donald St., P.O. Box 270, Waterloo Ia, 50704-0270

FUEL, OIL and TIME: Fuel No. 2 Diesel Specific gravity converted to 60°/60°F (15°/15°C) 0.8380 Fuel weight 6.977 lbs/gal (0.836 kg/l) Oil SAE 15W-40 API service classification CJ-4 Transmission, hydraulic and final drive lubricant John Deere Hy-Gard fluid Total time engine was operated: 20.0 hours

ENGINE: Make John Deere Diesel **Type** six cylinder vertical with turbocharger and air to air aftercooler **Serial No.** *RG6135L001633* **Crankshaft** lengthwise **Rated engine speed** 2100 **Bore and stroke** 5.197" x 6.496" (132.0 mm x 165.0 mm) **Compression ratio** 16.0 to 1 **Displacement** 826 cu in (13548 ml) **Starting system** 12 volt **Lubrication** pressure **Air cleaner** two paper elements and aspirator **Oil filter** one full flow cartridge **Oil cooler** engine coolant heat exchanger for crankcase oil, separate radiators for hydraulic and transmission oil, radiator for front and rear axle oil **Fuel filter** two paper cartridges **Fuel cooler** radiator for returned fuel **Muffler** vertical **Cooling medium temperature control** 3 thermostats and variable speed fan

ENGINE OPERATING PARAMETERS: Fuel rate: (425 engine hp) 144.0 - 155.6 lb/h (65.3 - 70.6 kg/h), (450 engine hp) 153.5 - 166.1 lb/h (69.6 - 75.3 kg/h), (475 engine hp) 160.4 - 173.7 lb/h (72.8 - 78.8 kg/h), (500 engine hp) 173.0 - 187.1 lb/h (78.5 - 84.9 kg/h), (530 engine hp) 182.5 - 197.3 lb/h (82.8 - 89.5 kg/h) **High idle:** 2220 - 2260 rpm **Turbo boost:** (530 engine hp) nominal 26.8 - 29.7 psi (185 - 205 kPa) as measured 28.5 psi (196 kPa)

CHASSIS: Type four wheel drive with triples **Serial No.** *RW9630P002190* **Tread width** rear 57.5" (1460 mm) to 163.8" (4160 mm) front 57.5" (1460 mm) to 163.8" (4160 mm) **Wheelbase** 137.7" (3498 mm) **Hydraulic control system** direct engine drive **Transmission** selective gear fixed ratio with full range operator controlled power shift **Nominal travel speeds mph (km/h)** first 2.42 (3.89) second 2.98 (4.79) third 3.29 (5.30) fourth 3.68 (5.92) fifth 4.05 (6.52) sixth 4.52 (7.28) seventh 5.01 (8.06) eighth 5.59 (9.00) ninth 6.16 (9.92) tenth 6.89 (11.08) eleventh 7.62 (12.27) twelfth 8.43 (13.56) thirteenth 9.38 (15.10) fourteenth 10.37 (16.69) fifteenth 12.82 (20.63) sixteenth 15.77 (25.38) seventeenth 19.50 (31.38) eighteenth 24.00 (38.62) reverse 2.42 (3.89), 3.29 (5.30), 3.68 (5.92), 5.01 (8.06), 5.59 (9.00), 7.62 (12.27)

DRAWBAR PERFORMANCE

(Unballasted at 2100 rpm)

MAXIMUM POWER IN SELECTED GEARS

| Power Hp (kW) | Drawbar pull lbs (kN) | Speed mph (km/h) | Crank- shaft speed rpm | Slip % | Fuel Consumption lb/hp.hr (kg/kW.h) | Fuel Consumption Hp.hr/gal (kW.h/l) | Temp. °F cool- ing med | Temp. °C Air dry bulb | Barom. inch Hg (kPa) |
|---------------------|--------------------------------|------------------------|---------------------------------|-----------|---|---|---------------------------------|--------------------------------|-------------------------------|
| 4th Gear | | | | | | | | | |
| 376.17 (280.51) | 40501 (180.16) | 3.48 (5.61) | 2112 | 7.2 | 0.471 (0.286) | 14.82 (2.92) | 190 (88) | 65 (18) | 28.40 (96.17) |
| 5th Gear | | | | | | | | | |
| 405.26 (302.21) | 39732 (176.73) | 3.83 (6.16) | 2101 | 5.5 | 0.464 (0.282) | 15.04 (2.96) | 198 (92) | 65 (18) | 28.40 (96.17) |
| 6th Gear | | | | | | | | | |
| 418.47 (312.05) | 36134 (160.73) | 4.34 (6.99) | 2098 | 4.0 | 0.462 (0.281) | 15.09 (2.97) | 207 (97) | 71 (22) | 28.67 (97.09) |
| 7th Gear | | | | | | | | | |
| 424.45 (316.51) | 32874 (146.23) | 4.84 (7.79) | 2099 | 3.4 | 0.457 (0.278) | 15.26 (3.01) | 202 (94) | 70 (21) | 28.67 (97.09) |
| 8th Gear | | | | | | | | | |
| 427.14 (318.52) | 29610 (131.71) | 5.41 (8.71) | 2098 | 3.1 | 0.453 (0.276) | 15.39 (3.03) | 202 (94) | 68 (20) | 28.69 (97.16) |
| 9th Gear | | | | | | | | | |
| 420.40 (313.49) | 26159 (116.36) | 6.03 (9.70) | 2098 | 2.3 | 0.461 (0.280) | 15.13 (2.98) | 201 (94) | 71 (22) | 28.66 (97.05) |
| 10th Gear | | | | | | | | | |
| 418.93 (312.40) | 23347 (103.85) | 6.73 (10.83) | 2098 | 2.1 | 0.462 (0.281) | 15.09 (2.97) | 207 (97) | 72 (22) | 28.66 (97.05) |
| 11th Gear | | | | | | | | | |
| 416.64 (310.69) | 20994 (93.39) | 7.44 (11.98) | 2097 | 1.9 | 0.466 (0.283) | 14.98 (2.95) | 203 (95) | 72 (22) | 28.66 (97.05) |
| 12th Gear | | | | | | | | | |
| 418.14 (311.81) | 18938 (84.24) | 8.28 (13.33) | 2099 | 1.7 | 0.461 (0.280) | 15.13 (2.98) | 206 (96) | 73 (23) | 28.65 (97.02) |

Clutch wet multiple disc hydraulically actuated by foot pedal **Brakes** wet multiple disc hydraulically actuated foot pedal **Steering** hydrostatic and articulated **Power take-off** None **Unladen tractor mass** 39465 lb (17901 kg)

REPAIRS AND ADJUSTMENTS: No repairs or adjustments.

NOTE: The 9630 engine has an electronic control system which provides a vehicle protection system to avoid overloading the drive train. This system provides five different engine power levels. At 2100 rpm the engine produces up to 425 hp when the transmission is in forward gears 1 and 2. At 2100 rpm the engine produces 450 hp when the transmission is in gear 3. At 2100 rpm the engine produces 475 hp when the transmission is in gear 4. At 2100 rpm the engine produces 500 hp when the transmission is in gear 5. At 2100 rpm the engine produces 530 hp in all other applications.

REMARKS: All test results were determined from observed data obtained in accordance with official OECD, SAE and Nebraska test procedures. For the maximum power tests the fuel temperature at the primary fuel filter was maintained at 105°F (41°C). The pull in 4th gear was limited to avoid excessive tractor bouncing. The performance figures on this summary were taken from a test conducted under the OECD Code II test code procedure.

We, the undersigned, certify that this is a true and correct report of official Tractor Test No. **1926**, Nebraska Summary 596, January 12, 2009.

Roger M. Hoy
Director

M.F. Kocher
V.I. Adamchuk
J.A. Smith
Board of Tractor Test Engineers

TRACTOR SOUND LEVEL WITH CAB

| | dB(A) |
|---------------------------------------|-------|
| At no load in 6th gear | 72.6 |
| Transport speed - no load - 18th gear | 74.8 |
| Bystander in 18th gear | 90.8 |

TIRES, BALLAST AND WEIGHT

| | With Ballast | Without Ballast |
|--|---------------------------|--------------------------|
| Rear Tires - No., size, ply & psi(kPa) | Six 480/80R46;***;14(85) | Six 480/80R46;***;10(70) |
| Ballast - Liquid (total) | None | None |
| - Cast Iron (total) | 8625 lb (3912 kg) | None |
| Front Tires - No., size, ply & psi(kPa) | Six 480/80R46;***;18(115) | Six 480/80R46;***;13(90) |
| Ballast - Liquid (total) | None | None |
| - Cast Iron (total) | 5900 lb (2675 kg) | None |
| Height of Drawbar | 21.0 in (535 mm) | 21.5 in (545 mm) |
| Static Weight with operator - Rear | 24895 lb(11292 kg) | 16270 lb (7380 kg) |
| - Front | 29270 lb(13277 kg) | 23370 lb(10600 kg) |
| - Total | 54165 lb(24569 kg) | 39640 lb(17980 kg) |

DRAWBAR PERFORMANCE
(Unballasted at 1850 RPM)
MAXIMUM POWER IN SELECTED GEARS

| Power Hp (kW) | Drawbar pull lbs (kN) | Speed mph (km/h) | Crank- shaft speed rpm | Slip % | Fuel Consumption lb/hp.hr (kg/kW.h) | Fuel Consumption Hp.hr/gal (kW.h/l) | Temp. °F(°C) cool- ing med | Air dry bulb | Barom. inch Hg (kPa) |
|---------------------|--------------------------------|------------------------|---------------------------------|-----------|---|---|-------------------------------------|--------------------|-------------------------------|
| 4th Gear | | | | | | | | | |
| 375.84 (280.26) | 40669 (180.90) | 3.47 (5.58) | 2109 | 7.3 | 0.473 (0.288) | 14.74 (2.90) | 193 (89) | 65 (18) | 28.40 (96.17) |
| 5th Gear | | | | | | | | | |
| 405.95 (302.72) | 39942 (177.67) | 3.81 (6.13) | 2097 | 6.1 | 0.464 (0.283) | 15.02 (2.96) | 201 (94) | 65 (18) | 28.40 (96.17) |
| 6th Gear | | | | | | | | | |
| 433.68 (323.40) | 38875 (172.92) | 4.18 (6.73) | 2057 | 5.8 | 0.473 (0.288) | 14.76 (2.91) | 205 (96) | 66 (19) | 28.39 (96.14) |
| 7th Gear | | | | | | | | | |
| 456.92 (340.72) | 38233 (170.07) | 4.48 (7.21) | 1989 | 5.5 | 0.469 (0.285) | 14.87 (2.93) | 201 (94) | 66 (19) | 28.38 (96.11) |
| 8th Gear | | | | | | | | | |
| 464.61 (346.46) | 37352 (166.15) | 4.66 (7.51) | 1856 | 5.4 | 0.466 (0.284) | 14.96 (2.95) | 200 (93) | 67 (19) | 28.38 (96.11) |
| 9th Gear | | | | | | | | | |
| 465.60 (347.20) | 33462 (148.84) | 5.22 (8.40) | 1849 | 3.9 | 0.466 (0.284) | 14.96 (2.95) | 201 (94) | 67 (19) | 28.38 (96.11) |
| 10th Gear | | | | | | | | | |
| 465.53 (347.14) | 29695 (132.09) | 5.88 (9.46) | 1858 | 3.4 | 0.467 (0.284) | 14.95 (2.94) | 203 (95) | 67 (19) | 28.38 (96.11) |
| 11th Gear | | | | | | | | | |
| 464.75 (346.56) | 26530 (118.01) | 6.57 (10.57) | 1870 | 2.9 | 0.466 (0.284) | 14.96 (2.95) | 202 (94) | 68 (20) | 28.37 (96.07) |
| 12th Gear | | | | | | | | | |
| 467.50 (348.61) | 23924 (106.42) | 7.33 (11.79) | 1865 | 2.2 | 0.465 (0.283) | 15.00 (2.95) | 202 (94) | 69 (21) | 28.37 (96.07) |
| 13th Gear | | | | | | | | | |
| 460.35 (343.28) | 21345 (94.95) | 8.09 (13.02) | 1852 | 2.0 | 0.469 (0.286) | 14.86 (2.93) | 204 (95) | 69 (21) | 28.37 (96.07) |

DRAWBAR PERFORMANCE
(Ballasted at 1850 RPM)
MAXIMUM POWER IN SELECTED GEARS

| Power Hp (kW) | Drawbar pull lbs (kN) | Speed mph (km/h) | Crank- shaft speed rpm | Slip % | Fuel Consumption lb/hp.hr (kg/kW.h) | Consumption Hp.hr/gal (kW.h/l) | Temp. °F(°C) cool- ing med | Air dry bulb | Barom. inch Hg (kPa) |
|---------------------|--------------------------------|------------------------|---------------------------------|-----------|---|--------------------------------------|-------------------------------------|--------------------|-------------------------------|
| 323.39 (241.15) | 53666 (238.72) | 2.26 (3.64) | 2118 | 8.1 | 0.492 (0.299) | 14.17 (2.79) | 184 (84) | 52 (11) | 28.41 (96.21) |
| 363.96 (271.40) | 51828 (230.54) | 2.63 (4.24) | 1980 | 6.8 | 0.476 (0.289) | 14.67 (2.89) | 191 (88) | 54 (12) | 28.40 (96.17) |
| 396.71 (295.83) | 50487 (224.58) | 2.95 (4.74) | 1991 | 6.2 | 0.460 (0.280) | 15.17 (2.99) | 191 (88) | 55 (13) | 28.40 (96.17) |
| 427.38 (318.69) | 49601 (220.63) | 3.23 (5.20) | 1944 | 6.0 | 0.461 (0.280) | 15.15 (2.98) | 200 (93) | 56 (13) | 28.40 (96.17) |
| 452.88 (337.72) | 48812 (217.13) | 3.48 (5.60) | 1899 | 5.3 | 0.458 (0.278) | 15.25 (3.00) | 202 (94) | 57 (14) | 28.39 (96.14) |
| 468.57 (349.41) | 46086 (205.00) | 3.81 (6.14) | 1854 | 4.4 | 0.463 (0.281) | 15.08 (2.97) | 201 (94) | 58 (14) | 28.38 (96.11) |
| 480.66 (358.42) | 42402 (188.61) | 4.25 (6.84) | 1852 | 4.0 | 0.451 (0.274) | 15.47 (3.05) | 201 (94) | 57 (14) | 28.38 (96.11) |
| 481.91 (359.36) | 38060 (169.30) | 4.75 (7.64) | 1850 | 3.6 | 0.450 (0.274) | 15.50 (3.05) | 201 (94) | 57 (14) | 28.39 (96.14) |
| 478.47 (356.79) | 33840 (150.53) | 5.30 (8.53) | 1853 | 3.0 | 0.453 (0.275) | 15.41 (3.03) | 201 (94) | 57 (14) | 28.39 (96.14) |
| 481.71 (359.21) | 30570 (135.98) | 5.91 (9.51) | 1853 | 2.6 | 0.450 (0.273) | 15.52 (3.06) | 202 (94) | 53 (12) | 28.40 (96.17) |
| 478.40 (356.74) | 27376 (121.77) | 6.55 (10.55) | 1853 | 2.3 | 0.452 (0.275) | 15.43 (3.04) | 203 (95) | 56 (13) | 28.40 (96.17) |
| 481.55 (359.09) | 24746 (110.07) | 7.30 (11.74) | 1853 | 1.9 | 0.450 (0.274) | 15.52 (3.06) | 202 (94) | 57 (14) | 28.39 (96.14) |
| 471.92 (351.91) | 21828 (97.09) | 8.11 (13.05) | 1850 | 1.7 | 0.458 (0.279) | 15.23 (3.00) | 202 (94) | 57 (14) | 28.39 (96.14) |

HYDRAULIC PERFORMANCE

CATEGORY: IVN, IV

Quick Attach: yes

OECD Static test

Maximum force exerted through whole range: 15677 lbs (69.7 kN) (Cat IVN)
15769 lbs (70.1 kN) (Cat IV)

- i) Opening pressure of relief valve: NA
Sustained pressure at compensator cutoff: 2964 psi (204 bar)
Single outlet set Three outlet sets combined
- ii) Pump delivery rate at minimum pressure and rated engine speed: 38.0 GPM (143.8 l/min) 51.0 GPM (193.2 l/min)
- iii) Pump delivery rate at maximum hydraulic power: 36.3 GPM (137.3 l/min) 50.5 GPM (191.1 l/min)
Delivery pressure: 2092 psi (144 bar) 2411 psi (166 bar)
Power: 44.2 HP (33.0 kW) 71.0 HP (53.0 kW)

HITCH DIMENSIONS AS TESTED—NO LOAD

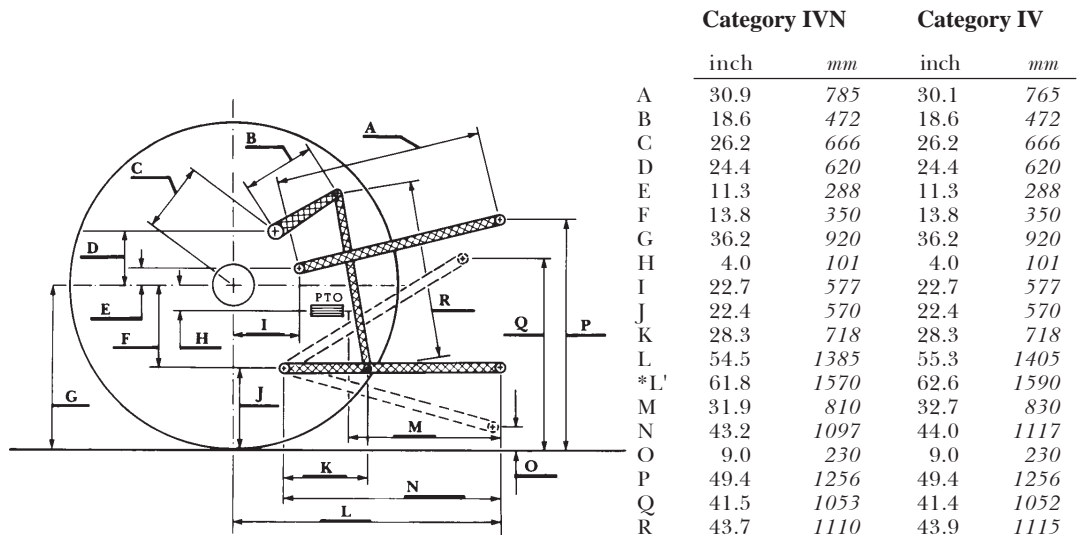

*L' to Quick Attach ends



JOHN DEERE 9630 DIESEL