

NEBRASKA OECD TRACTOR TEST 1973—SUMMARY 734

JOHN DEERE 8345RT DIESEL

INFINITELY VARIABLE TRANSMISSION

POWER TAKE-OFF PERFORMANCE

Power HP (kW)	Crank shaft speed rpm	Gal/hr (l/h)	lb/hp.hr (kg/kW.h)	Hp.hr/gal (kW.h/l)	Mean Atmospheric Conditions
MAXIMUM POWER AND FUEL CONSUMPTION					
Rated Engine Speed—(PTO speed—1048 rpm)					
278.85 (207.93)	2096	15.57 (58.93)	0.392 (0.238)	17.91 (3.53)	
Standard Power Take-off Speed(1000 rpm)					
306.28 (228.39)	2000	16.87 (63.87)	0.387 (0.235)	18.15 (3.58)	
Maximum Power (1 hour)					
318.85 (237.77)	1800	17.28 (65.41)	0.381 (0.231)	18.45 (3.63)	

VARYING POWER AND FUEL CONSUMPTION

278.85 (207.93)	2096	15.57 (58.93)	0.392 (0.238)	17.91 (3.53)	Air temperature
243.71 (181.73)	2153	14.29 (54.08)	0.412 (0.250)	17.06 (3.36)	73°F (23°C)
183.53 (136.86)	2162	11.74 (44.44)	0.449 (0.273)	15.63 (3.08)	Relative humidity
123.04 (91.73)	2172	8.92 (33.77)	0.509 (0.310)	13.79 (2.72)	14%
61.91 (46.16)	2185	6.12 (23.17)	0.694 (0.422)	10.11 (1.99)	Barometer
1.57 (1.17)	2194	4.45 (16.83)	19.882 (12.094)	0.35 (0.07)	28.77" Hg (97.43 kPa)

Maximum torque - 1039 lb.-ft. (1409 Nm) at 1500 rpm

Maximum torque rise - 48.9%

Torque rise at 1698 engine rpm - 40%

Power increase at 1800 rpm - 14.3%

DRAWBAR PERFORMANCE (Unballasted)

FUEL CONSUMPTION CHARACTERISTICS

Power Hp (kW)	Drawbar pull lbs (kN)	Speed mph (km/h)	Crank- shaft speed rpm	Slip %	Fuel Consumption lb/hp.hr (kg/kW.h)	Hp.hr/gal (kW.h/l)	Temp.°F (°C) cool- ing med	Air dry bulb	Barom. inch Hg (kPa)
Maximum Power—5.1 mph (8.2 km/h)									
240.19 (179.11)	18583 (82.66)	4.85 (7.81)	2097	2.5	0.451 (0.274)	15.56 (3.07)	193 (90)	62 (17)	29.10 (98.54)
75% of Pull at Maximum Power—5.1 mph (8.2 km/h)									
187.47 (139.79)	13967 (62.13)	5.04 (8.10)	2155	1.6	0.498 (0.303)	14.09 (2.78)	188 (87)	64 (18)	29.11 (98.58)
50% of Pull at Maximum Power—5.1 mph (8.2 km/h)									
125.99 (93.95)	9282 (41.29)	5.09 (8.19)	2167	0.8	0.572 (0.348)	12.29 (2.42)	184 (85)	65 (18)	29.12 (98.61)
75% of Pull at Reduced Engine Speed—Auto mode									
187.23 (139.62)	13991 (62.23)	5.02 (8.08)	1738	1.5	0.472 (0.287)	14.89 (2.93)	191 (88)	64 (18)	29.11 (98.58)
50% of Pull at Reduced Engine Speed—Auto mode									
125.84 (93.84)	9344 (41.56)	5.05 (8.13)	1425	0.8	0.477 (0.290)	14.71 (2.90)	191 (88)	65 (18)	29.12 (98.61)

Location of tests: Nebraska Tractor Test Laboratory, University of Nebraska, Lincoln, Nebraska 68583-0832

Dates of tests: May 5-21, 2010

Manufacturer: John Deere Tractor Works, 3500 East Donald St., P.O. Box 270, Waterloo Ia, 50704-0270

FUEL, OIL and TIME: Fuel No. 2 Diesel Specific gravity converted to 60°/60°F (15°/15°C) 0.8433 Fuel weight 7.022 lbs/gal (0.842 kg/l) Oil SAE 15W-40 API service classification CI-4 Transmission and hydraulic lubricant John Deere Hy-Gard fluid Total time engine was operated: 28.0 hours

ENGINE: Make John Deere Diesel Type six cylinder vertical with turbocharger and air to air aftercooler Serial No.*RG6090L070111* Crankshaft lengthwise Rated engine speed 2100 Bore and stroke 4.661" x 5.354" (118.4 mm x 136.0 mm) Compression ratio 16.3 to 1 Displacement 548 cu in (8984 ml) Starting system 12 volt Lubrication pressure Air cleaner two paper elements and aspirator Oil filter one full flow cartridge Oil cooler engine coolant heat exchanger for crankcase oil, radiator for hydraulic and transmission oil Fuel filter one paper element and prestrainer Fuel cooler radiator for pump return fuel Muffler vertical Cooling medium temperature control 2 thermostats and variable speed fan

ENGINE OPERATING PARAMETERS: Fuel rate: 108.2 - 117.1 lb/h (49.1 - 53.1 kg/h) High idle: 2175 - 2225 rpm Turbo boost: nominal 29.0 - 33.4 psi (200 - 230 kPa) as measured 30.3 psi (209 kPa)

CHASSIS: Type tracklayer-rubber tracked Serial No.*1RW8345RP9D901310* Track width 76.0" (1930 mm) to 120.0" (3048 mm) Length of track on ground 99.0" (2515 mm) Hydraulic control system direct engine drive Transmission Infinitely variable with four mechanical ranges and automatic shifting between ranges. Nominal travel speeds mph (km/h) forward - 0 - 26.1 mph, (0 - 42 km/h) reverse - 0 - 11.8 mph (0 - 19 km/h) Clutch a foot pedal controls the hydrostatic oil flow Brakes wet multiple disc hydraulically actuated by foot pedal Steering electro-hydraulic differential steering controlled by steering wheel Power take-off 1000 rpm at 2000 engine rpm Unladen tractor mass 34670 lb (15726 kg)

DRAWBAR PERFORMANCE
UNBALLASTED - 2100 RPM
MAXIMUM POWER AT SELECTED SPEED SETTINGS

Power Hp (kW)	Drawbar pull lbs (kN)	Speed mph (km/h)	Crank- shaft speed rpm	Slip %	Fuel Consumption lb/hp.hr (kg/kW.h)	Fuel Consumption Hp.hr/gal (kW.h/l)	Temp. °F (°C) cool- ing med	Air dry bulb	Barom. inch Hg (kPa)
200.44 (149.46)	34188 (152.07)	2.20 (3.54)	2110	13.8	0.542 (0.330)	12.95 (2.55)	174 (79)	49 (9)	29.07 (98.44)
220.34 (164.30)	30936 (137.61)	2.67 (4.30)	2100	9.3	0.493 (0.300)	14.25 (2.81)	184 (84)	52 (11)	29.07 (98.44)
227.36 (169.54)	26661 (118.60)	3.20 (5.15)	2099	6.2	0.476 (0.290)	14.75 (2.91)	187 (86)	59 (15)	29.09 (98.51)
233.08 (173.81)	24329 (108.22)	3.60 (5.79)	2098	4.9	0.465 (0.283)	15.09 (2.97)	190 (88)	64 (18)	29.10 (98.54)
235.81 (175.84)	21583 (96.01)	4.10 (6.59)	2099	3.7	0.460 (0.280)	15.25 (3.00)	190 (88)	64 (18)	29.10 (98.54)
239.87 (178.87)	20136 (89.57)	4.47 (7.19)	2098	3.0	0.453 (0.275)	15.51 (3.05)	189 (87)	63 (17)	29.10 (98.54)
240.19 (179.11)	18583 (82.66)	4.85 (7.81)	2097	2.5	0.451 (0.274)	15.56 (3.07)	193 (90)	62 (17)	29.10 (98.54)
236.24 (176.16)	16599 (73.84)	5.34 (8.59)	2098	2.2	0.460 (0.280)	15.27 (3.01)	191 (88)	58 (14)	28.76 (97.39)
234.88 (175.15)	14781 (65.75)	5.96 (9.58)	2099	1.9	0.462 (0.281)	15.22 (3.00)	192 (89)	58 (14)	28.77 (97.43)
231.82 (172.87)	13213 (58.77)	6.58 (10.58)	2100	1.6	0.466 (0.284)	15.07 (2.97)	190 (88)	58 (14)	28.77 (97.43)
230.59 (171.95)	12043 (53.57)	7.18 (11.56)	2098	1.3	0.470 (0.286)	14.93 (2.94)	194 (90)	58 (14)	28.78 (97.46)
229.60 (171.21)	11043 (49.12)	7.80 (12.55)	2096	1.0	0.472 (0.287)	14.89 (2.93)	192 (89)	52 (11)	29.06 (98.41)
227.07 (169.33)	10104 (44.94)	8.43 (13.56)	2099	0.8	0.478 (0.291)	14.69 (2.89)	188 (86)	55 (13)	29.07 (98.44)

TRACTOR SOUND LEVEL WITH CAB	dB(A)
At no load at 4.6mph(7.5 km/h) engine speed-2190rpm	69.8
At no load at 4.6mph(7.5 km/h) engine speed-1400rpm	65.9
Transport speed-no load	73.9
Bystander	86.2

TIRES AND WEIGHT	Tested Without Ballast
Track width	25.0 in (635 mm)
Height of Drawbar	18.0 in (455 mm)
Static Weight with operator	34845 lb(15805 kg)

REPAIRS AND ADJUSTMENTS: A leak developed during the hydraulic power tests. An "O" ring seal in the selective control valve coupler was replaced and tests continued.

REMARKS: All test results were determined from observed data obtained in accordance with official OECD, SAE and Nebraska test procedures. For the maximum power tests the fuel temperature at the injection pump inlet was maintained at 113°F(45°C). The performance figures on this summary were taken from a test conducted under the OECD Code 2 test procedure.

We, the undersigned, certify that this is a true and correct report of official Tractor Test No. **1973**, Nebraska Summary 734, July 27, 2010.

Roger M. Hoy
 Director

M.F. Kocher
 D.R. Keshwani
 J.A. Smith
 Board of Tractor Test Engineers

DRAWBAR PERFORMANCE
UNBALLASTED - 1800 RPM
MAXIMUM POWER AT SELECTED SPEED SETTINGS

Power Hp (kW)	Drawbar pull lbs (kN)	Speed mph (km/h)	Crank- shaft speed rpm	Slip %	Fuel Consumption lb/hp.hr (kg/kW.h)	Temp. °F(°C) cool- ing med	Temp. °F(°C) Air dry bulb	Barom. inch Hg (kPa)	
201.33 (150.13)	34212 (152.18)	2.21 (3.55)	2109	13.0	0.531 (0.323)	13.24 (2.61)	172 (78)	48 (9)	29.06 (98.41)
223.01 (166.29)	32173 (143.11)	2.60 (4.18)	2078	11.0	0.496 (0.301)	14.17 (2.79)	186 (85)	54 (12)	29.08 (98.48)
242.15 (180.57)	31328 (139.35)	2.90 (4.67)	1982	10.5	0.483 (0.294)	14.54 (2.86)	188 (86)	61 (16)	29.09 (98.51)
250.26 (186.62)	30005 (133.47)	3.13 (5.04)	1917	9.9	0.476 (0.290)	14.75 (2.91)	187 (86)	64 (18)	29.10 (98.54)
257.47 (191.99)	27994 (124.52)	3.45 (5.55)	1838	8.0	0.466 (0.283)	15.07 (2.97)	187 (86)	64 (18)	29.11 (98.58)
267.13 (199.20)	26184 (116.47)	3.83 (6.16)	1841	5.6	0.449 (0.273)	15.65 (3.08)	190 (88)	63 (17)	29.10 (98.54)
269.00 (200.59)	24425 (108.65)	4.13 (6.65)	1825	4.9	0.446 (0.271)	15.76 (3.10)	190 (88)	63 (17)	29.10 (98.54)
268.65 (200.33)	22362 (99.47)	4.51 (7.25)	1809	4.3	0.445 (0.271)	15.77 (3.11)	193 (89)	58 (14)	28.77 (97.43)
270.10 (201.41)	20068 (89.27)	5.05 (8.13)	1806	3.4	0.444 (0.270)	15.82 (3.12)	192 (89)	58 (14)	28.77 (97.43)
269.93 (201.28)	18146 (80.72)	5.58 (8.97)	1802	2.7	0.446 (0.271)	15.75 (3.10)	192 (89)	58 (14)	28.78 (97.46)
271.05 (202.12)	16594 (73.81)	6.13 (9.86)	1801	2.0	0.441 (0.268)	15.93 (3.14)	192 (89)	59 (15)	28.78 (97.46)
268.47 (200.20)	15125 (67.28)	6.66 (10.71)	1802	1.6	0.445 (0.271)	15.80 (3.11)	190 (88)	53 (12)	29.07 (98.44)
270.17 (201.46)	14084 (62.65)	7.19 (11.57)	1803	1.3	0.442 (0.269)	15.89 (3.13)	190 (88)	55 (13)	29.07 (98.44)
269.45 (200.93)	13114 (58.34)	7.71 (12.40)	1801	1.1	0.442 (0.269)	15.90 (3.13)	189 (87)	57 (14)	29.08 (98.48)
267.70 (199.62)	12203 (54.28)	8.23 (13.24)	1801	0.9	0.445 (0.271)	15.77 (3.11)	190 (88)	59 (15)	29.10 (98.54)

DRAWBAR PERFORMANCE
UNBALLASTED - AUTO MODE
MAXIMUM POWER AT SELECTED SPEED SETTINGS

Power Hp (kW)	Drawbar pull lbs (kN)	Speed mph (km/h)	Crank- shaft speed rpm	Slip %	Fuel Consumption lb/hp.hr (kg/kW.h)	Temp.°F (°C) cool- ing med	Air dry bulb	Barom. inch Hg (kPa)	
203.17 (151.50)	34188 (152.07)	2.23 (3.59)	2005	14.0	0.523 (0.318)	13.42 (2.64)	181 (83)	50 (10)	29.07 (98.44)
223.14 (166.40)	32197 (143.22)	2.60 (4.18)	2080	11.0	0.495 (0.301)	14.20 (2.80)	186 (86)	55 (13)	29.08 (98.48)
241.74 (180.27)	31247 (138.99)	2.90 (4.67)	1991	10.9	0.482 (0.293)	14.56 (2.87)	189 (87)	63 (17)	29.09 (98.51)
248.33 (185.18)	29691 (132.07)	3.14 (5.05)	1945	9.4	0.476 (0.290)	14.75 (2.91)	189 (87)	64 (18)	29.11 (98.58)
252.19 (188.06)	27798 (123.65)	3.40 (5.47)	1949	8.0	0.468 (0.285)	14.99 (2.95)	188 (86)	65 (18)	29.12 (98.61)
259.57 (193.56)	25889 (115.16)	3.76 (6.05)	1948	5.6	0.456 (0.277)	15.41 (3.03)	189 (87)	63 (17)	29.10 (98.54)
264.31 (197.09)	24422 (108.63)	4.06 (6.53)	1948	4.7	0.447 (0.272)	15.69 (3.09)	190 (88)	63 (17)	29.10 (98.54)
266.20 (198.50)	22231 (98.89)	4.49 (7.23)	1949	3.8	0.445 (0.271)	15.77 (3.11)	188 (87)	63 (17)	29.10 (98.54)
264.44 (197.19)	20106 (89.44)	4.93 (7.93)	1949	3.1	0.445 (0.271)	15.81 (3.11)	190 (88)	47 (8)	29.05 (98.37)
266.73 (198.90)	18137 (80.68)	5.52 (8.88)	1957	2.6	0.443 (0.270)	15.84 (3.12)	193 (90)	64 (18)	29.11 (98.58)
265.68 (198.11)	16904 (75.19)	5.89 (9.48)	1949	2.2	0.446 (0.271)	15.74 (3.10)	189 (87)	50 (10)	29.06 (98.41)
262.10 (195.44)	15128 (67.29)	6.50 (10.46)	1948	1.8	0.450 (0.274)	15.63 (3.08)	190 (88)	54 (12)	29.07 (98.44)
263.44 (196.44)	13910 (61.87)	7.10 (11.43)	1949	1.5	0.450 (0.273)	15.62 (3.08)	190 (88)	55 (13)	29.08 (98.48)
262.86 (196.01)	12931 (57.52)	7.62 (12.26)	1950	1.3	0.448 (0.273)	15.66 (3.08)	188 (87)	58 (14)	29.09 (98.51)
261.10 (194.70)	11940 (53.11)	8.20 (13.20)	1949	1.2	0.453 (0.275)	15.51 (3.06)	187 (86)	60 (16)	29.10 (98.54)

HYDRAULIC PERFORMANCE

CATEGORY: IVN

Quick Attach: yes

OECD Static test

Maximum force exerted through whole range:

21167 lbs (94.2 kN)

	<u>63 cc pump</u>	<u>85 cc pump</u>
i) Sustained pressure at compensator cutoff:	2973 psi (205 bar)	2910 psi (201 bar)
	three outlet sets combined	

ii) Pump delivery rate at minimum pressure and rated engine speed:	48.4 GPM (183.3 l/min)	65.2 GPM (246.7 l/min)
--	------------------------	------------------------

iii) Pump delivery rate at maximum hydraulic power:	47.4 GPM (179.5 l/min)	64.1 GPM (242.5 l/min)
Delivery pressure:	2740 psi (189 bar)	2465 psi (170 bar)
Power:	75.8 HP (56.5 kW)	92.1 HP (68.7 kW)
	single outlet set	

ii) Pump delivery rate at minimum pressure and rated engine speed:	41.2 GPM (155.9 l/min)	41.8 GPM (158.2 l/min)
--	------------------------	------------------------

iii) Pump delivery rate at maximum hydraulic power:	39.4 GPM (149.1 l/min)	40.5 GPM (153.3 l/min)
Delivery pressure:	2286 psi (158 bar)	2151 psi (148 bar)
Power:	52.5 HP (39.2 kW)	50.8 HP (37.9 kW)

HITCH DIMENSIONS AS TESTED - NO LOAD

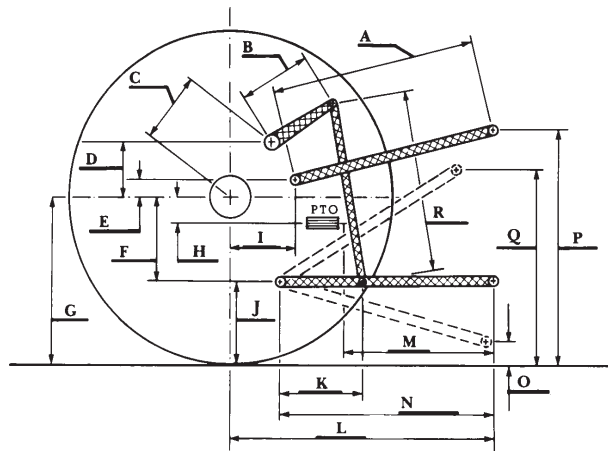

	inch	mm
A	28.1	715
B	20.5	520
C	24.8	631
D	24.2	615
E	12.6	320
F	11.5	292
G	35.0	888
H	3.1	80
I	18.5	470
J	23.5	596
K	39.8	1011
L	53.6	1361
*L'	59.5	1511
M	30.6	777
N	45.7	1161
O	9.0	230
P	50.5	1283
Q	41.1	1043
R	44.7	1135

*L' to Quick Attach ends



JOHN DEERE 8345RT DIESEL

Institute of Agriculture and Natural Resources
University of Nebraska-Lincoln