

Location of Test: Nebraska Tractor Test Laboratory, University of Nebraska, Lincoln, Nebraska 68583-0832

Dates of Test: April 17-May 12, 2000

Manufacturer: John Deere Waterloo Works, P.O. Box 270, Waterloo Ia, USA

FUEL, OIL and TIME: Fuel No. 2 Diesel Specific gravity converted to 60°/60°F (15°/15°C) 0.8487 Fuel weight 7.067 lbs/gal (0.847 kg/l) Oil SAE 15W-40 API service classification CF-4 Transmission and hydraulic lubricant John Deere Hy-Gard fluid Total time engine was operated: 33.5 hours

ENGINE: Make John Deere Diesel Type six cylinder vertical with turbocharger and air to air aftercooler Serial No. *RG6081H098909* Crankshaft lengthwise Rated engine speed 2200 Bore and stroke 4.56" x 5.06"(115.8 mm x 128.5 mm) Compression ratio 16.5 to 1 Displacement 496 cu in (8134 ml) Starting system 12 volt Lubrication pressure Air cleaner two paper elements and aspirator Oil filter one full flow cartridge Oil cooler engine coolant heat exchanger for crankcase oil, radiator for hydraulic and transmission oil Fuel filter one paper element and prestrainer Fuel cooler radiator for pump return fuel Muffler vertical Cooling medium temperature control 2 thermostats and variable speed fan

ENGINE OPERATING PARAMETERS: Fuel rate: 79.9 - 87.4 lb/h (36.3 - 39.6 kg/h) High idle: 2275 - 2325 rpm Turbo boost: nominal 18.7 - 23.1 psi (129 - 159 kPa) as measured 20.4 psi (140 kPa)

CHASSIS: Type tracklayer-rubber tracked Serial No. *RW8310T901079* Track width 88.0" (2235 mm) to 119.5 (3035 mm) Length of track on ground 89.0" (2261 mm) Hydraulic control system direct engine drive Transmission selective gear fixed ratio with full range operator controlled power shift Nominal travel speeds mph (km/h) first 1.16 (1.87) second 1.49 (2.39) third 1.89 (3.04) fourth 2.41 (3.88) fifth 2.92(4.70) sixth 3.30 (5.31) seventh 3.73(6.01) eighth 4.21(6.78) ninth 4.75(7.65) tenth 5.36(8.63) eleventh 6.07(9.77) twelfth 6.85(11.02) thirteenth 8.71 (14.02) fourteenth 11.13(17.91) fifteenth 14.17(22.80) sixteenth 18.10(29.13) reverse 1.01 (1.63), 2.55 (4.10), 2.88 (4.63), 5.53 (8.90)@1600 engine rpm Clutch wet multiple disc hydraulically actuated by foot pedal Brakes wet multiple disc hydraulically actuated foot pedal Steering electro-hydraulic differential steering controlled by steering wheel Power take-off 1000 rpm at 179 engine rpm Unladen tractor mass 25960 lb (11775 kg)

POWER TAKE-OFF PERFORMANCE

Power HP (kW)	Crank shaft speed rpm	Gal/hr (l/h)	lb/hp.hr (kg/kW.h)	Hp.hr/gal (kW.h/l)	Mean Atmospheric Conditions
MAXIMUM POWER AND FUEL CONSUMPTION					
Rated Engine Speed (PTO speed 1009 rpm)					
206.33 (153.86)	2200	11.83 (44.77)	0.405 (0.246)	17.45 (3.44)	
Maximum Power (2 hours)					
235.12 (175.33)	1999	12.53 (47.42)	0.377 (0.229)	18.77 (3.70)	
VARYING POWER AND FUEL CONSUMPTION					
206.33 (153.86)	2200	11.83 (44.77)	0.405 (0.246)	17.45 (3.44)	Air temperature
179.25 (133.67)	2254	10.70 (40.49)	0.422 (0.257)	16.76 (3.30)	75°F(24°C)
134.82 (100.53)	2265	8.70 (32.94)	0.456 (0.277)	15.49 (3.05)	Relative humidity
90.31 (67.34)	2274	6.66 (25.23)	0.522 (0.317)	13.55 (2.67)	47%
44.90 (33.48)	2286	4.67 (17.68)	0.735 (0.447)	9.61 (1.89)	Barometer
2.50 (1.87)	2293	2.97 (11.25)	8.387 (5.102)	0.84 (0.17)	29.03" Hg(98.31 kPa)

Maximum Torque - 729 lb.-ft. (988 Nm) at 1202 rpm
 Maximum Torque Rise - 48.1%
 Torque rise at 1799 engine rpm - 36%

**DRAWBAR PERFORMANCE(Unballasted)
FUEL CONSUMPTION CHARACTERISTICS**

Power Hp (kW)	Drawbar pull lbs (kN)	Speed mph (km/h)	Crank-shaft speed rpm	Slip %	Fuel Consumption lb/hp.hr (kg/kW.h)	Hp.hr/gal (kW.h/l)	Temp. °F (°C) cooling med	Air dry bulb	Barom. inch Hg (kPa)
Maximum Power 9th Gear									
177.43 (132.31)	14334 (63.76)	4.64 (7.47)	2198	2.05	0.472 (0.287)	14.96 (2.95)	191 (88)	65 (18)	28.99 (98.17)
75% of Pull at Maximum Power 9th Gear									
136.83 (102.04)	10655 (47.39)	4.82 (7.75)	2258	1.28	0.513 (0.312)	13.78 (2.71)	184 (84)	68 (20)	28.98 (98.14)
50% of Pull at Maximum Power 9th Gear									
92.25 (68.79)	7112 (31.63)	4.86 (7.83)	2270	0.81	0.596 (0.362)	11.86 (2.34)	182 (83)	69 (21)	28.96 (98.07)
75% of Pull at Reduced Engine Speed 11th Gear									
136.53 (101.81)	10681 (47.51)	4.79 (7.71)	1759	1.36	0.443 (0.270)	15.95 (3.14)	194 (90)	69 (21)	28.97 (98.10)
50% of Pull at Reduced Engine Speed 11th Gear									
92.07 (68.66)	7116 (31.65)	4.85 (7.81)	1772	0.81	0.501 (0.305)	14.11 (2.78)	185 (85)	69 (21)	28.95 (98.04)

DRAWBAR PERFORMANCE(Unballasted)

MAXIMUM POWER IN SELECTED GEARS

Power Hp (kW)	Drawbar pull lbs (kN)	Speed mph (km/h)	Crank- shaft speed rpm	Slip %	Fuel Consumption lb/hp.hr (kg/kW.h)	Fuel Consumption Hp.hr/gal (kW.h/l)	Temp. °F (°C) cool- ing med	Air dry bulb	Barom. inch Hg (kPa)
3rd Gear									
113.97 (84.99)	25919 (115.29)	1.65 (2.65)	2249	14.61	0.584 (0.355)	12.09 (2.38)	183 (84)	57 (14)	29.01 (98.24)
4th Gear									
132.66 (98.93)	23965 (106.60)	2.08 (3.34)	2120	10.69	0.523 (0.318)	13.51 (2.66)	186 (85)	61 (16)	29.01 (98.24)
5th Gear									
159.35 (118.83)	23777 (105.77)	2.51 (4.04)	2103	10.05	0.494 (0.300)	14.31 (2.82)	191 (88)	61 (16)	29.00 (98.21)
6th Gear									
178.65 (133.22)	23804 (105.88)	2.81 (4.53)	2095	10.37	0.488 (0.297)	14.47 (2.85)	187 (86)	62 (17)	29.00 (98.21)
7th Gear									
189.37 (141.21)	23077 (102.65)	3.08 (4.95)	1999	9.33	0.467 (0.284)	15.14 (2.98)	188 (86)	63 (17)	28.99 (98.17)
8th Gear									
197.33 (147.15)	20532 (91.33)	3.60 (5.80)	1998	5.83	0.447 (0.272)	15.79 (3.11)	189 (87)	63 (17)	28.99 (98.17)
9th Gear									
200.42 (149.45)	18085 (80.44)	4.16 (6.69)	2003	3.94	0.440 (0.268)	16.06 (3.16)	187 (86)	66 (19)	28.99 (98.17)
10th Gear									
201.90 (150.55)	16010 (71.21)	4.73 (7.61)	2000	3.12	0.437 (0.266)	16.19 (3.19)	191 (88)	66 (19)	28.99 (98.17)
11th Gear									
201.45 (150.22)	13981 (62.19)	5.40 (8.70)	2002	2.21	0.439 (0.267)	16.10 (3.17)	192 (89)	67 (19)	28.98 (98.14)
12th Gear									
200.61 (149.60)	12274 (54.60)	6.13 (9.86)	2002	1.75	0.439 (0.267)	16.11 (3.17)	194 (90)	67 (19)	28.98 (98.14)
13th Gear									
198.02 (147.66)	9467 (42.11)	7.84 (12.62)	2001	1.04	0.445 (0.271)	15.86 (3.13)	195 (91)	67 (19)	28.98 (98.14)

REPAIRS AND ADJUSTMENTS: No repairs or adjustments.

NOTE: The 8310T engine has an electronic control system which provides a vehicle protection system to avoid overloading the drive train. This system provides three different engine power levels. The engine produces up to 165 PTO hp when the transmission is in forward gears 1 through 4 and the PTO is not engaged. The engine produces up to 185 PTO hp when the transmission is in 5th forward gear and the PTO is not engaged. The engine produces up to 205 PTO Hp in all other applications.

REMARKS: All test results were determined from observed data obtained in accordance with official OECD, SAE and Nebraska test procedures. For the maximum power tests the fuel temperature at the injection pump inlet was maintained at 117°F(47°C). The performance figures on this summary were taken from a test conducted under the OECD Code II test procedure.

We, the undersigned, certify that this is a true and correct report of official Tractor Test No. **1776**, Nebraska Summary 311, July 7, 2000.

Leonard L. Bashford
Director

G. J. Hoffman
M. F. Kocher
R. D. Grisso, Jr.
Board of Tractor Test Engineers

TRACTOR SOUND LEVEL WITH CAB

dB(A)

At no load in 9th gear	74.2
Transport speed - no load - 16th gear	77.7
Bystander in 16th Gear	89.7

TIRES, BALLAST AND WEIGHT

	With Ballast	Without Ballast
Track width	24.0 in (610 mm)	24.0 in (610 mm)
Ballast - Cast iron(front)	2200 lb (997 kg)	None
Height of Drawbar	18.5 in (470 mm)	18.5 in (470 mm)
Static Weight with operator	28335 lb(12852 kg)	26135 lb(11855 kg)

DRAWBAR PERFORMANCE
(Ballasted - 2000 RPM)

MAXIMUM POWER IN SELECTED GEARS

Power Hp (kW)	Drawbar pull lbs (kN)	Speed mph (km/h)	Crank- shaft speed rpm	Slip %	Fuel Consumption lb/hp.hr (kg/kW.h)	Temp. °F(°C) cool- ing med	Temp. °F(°C) Air dry bulb	Barom. inch Hg (kPa)	
2nd Gear									
103.41 (77.11)	29749 (132.33)	1.30 (2.10)	2255	14.46	0.600 (0.365)	11.77 (2.32)	182 (83)	55 (13)	28.84 (97.66)
3rd Gear									
122.24 (91.16)	27693 (123.18)	1.66 (2.66)	2189	12.16	0.551 (0.335)	12.82 (2.53)	183 (84)	58 (14)	28.86 (97.73)
4th Gear									
144.02 (107.40)	25835 (114.92)	2.09 (3.36)	2063	7.67	0.488 (0.297)	14.48 (2.85)	185 (85)	59 (15)	28.87 (97.77)
5th Gear									
169.43 (126.34)	26006 (115.68)	2.44 (3.93)	2001	8.22	0.469 (0.285)	15.07 (2.97)	188 (86)	59 (15)	28.87 (97.77)
6th Gear									
192.18 (143.31)	26046 (115.86)	2.77 (4.45)	2001	8.01	0.461 (0.280)	15.34 (3.02)	190 (88)	60 (16)	28.88 (97.80)
7th Gear									
197.88 (147.56)	23118 (102.83)	3.21 (5.17)	1999	5.57	0.447 (0.272)	15.81 (3.11)	190 (88)	60 (16)	28.88 (97.80)
8th Gear									
202.43 (150.95)	20565 (91.48)	3.69 (5.94)	1998	3.59	0.438 (0.266)	16.13 (3.18)	189 (87)	61 (16)	28.90 (97.87)
9th Gear									
203.40 (151.67)	18094 (80.49)	4.22 (6.78)	2001	2.54	0.434 (0.264)	16.27 (3.20)	191 (88)	62 (17)	28.91 (97.90)
10th Gear									
204.75 (152.68)	16062 (71.45)	4.78 (7.69)	1998	2.15	0.431 (0.262)	16.38 (3.23)	191 (88)	60 (16)	28.92 (97.93)
11th Gear									
202.77 (151.21)	13978 (62.17)	5.44 (8.75)	1999	1.53	0.435 (0.265)	16.25 (3.20)	192 (89)	60 (16)	28.92 (97.93)
12th Gear									
201.07 (149.94)	12250 (54.49)	6.16 (9.91)	1999	1.30	0.438 (0.266)	16.13 (3.18)	195 (90)	60 (16)	28.92 (97.93)
13th Gear									
196.77 (146.73)	9365 (41.66)	7.88 (12.68)	2004	0.99	0.450 (0.274)	15.69 (3.09)	194 (90)	60 (16)	28.92 (97.93)

DRAWBAR PERFORMANCE
(Ballasted - 2200 RPM)
MAXIMUM POWER IN SELECTED GEARS

Power Hp (kW)	Drawbar pull lbs (kN)	Speed mph (km/h)	Crank- shaft speed rpm	Slip %	Fuel Consumption lb/hp.hr (kg/kW.h)	Temp. °F(°C) cool- ing med	Air dry bulb	Barom. inch Hg (kPa)	
2nd Gear									
101.56 (75.73)	29132 (129.58)	1.31 (2.10)	2255	14.23	0.602 (0.366)	11.74 (2.31)	181 (83)	55 (13)	28.84 (97.66)
3rd Gear									
124.75 (93.02)	27338 (121.60)	1.71 (2.75)	2202	9.62	0.537 (0.327)	13.15 (2.59)	184 (84)	56 (13)	28.85 (97.70)
4th Gear									
132.51 (98.81)	21440 (95.37)	2.32 (3.73)	2199	4.26	0.509 (0.310)	13.89 (2.74)	185 (85)	59 (15)	28.86 (97.73)
5th Gear									
155.64 (116.06)	20754 (92.32)	2.81 (4.53)	2199	3.82	0.482 (0.293)	14.67 (2.89)	184 (84)	59 (15)	28.87 (97.77)
6th Gear									
177.93 (132.68)	20984 (93.34)	3.18 (5.12)	2202	3.74	0.471 (0.286)	15.01 (2.96)	186 (85)	60 (16)	28.88 (97.80)
7th Gear									
177.78 (132.57)	18372 (81.72)	3.63 (5.84)	2199	2.84	0.471 (0.286)	15.00 (2.96)	186 (85)	61 (16)	28.90 (97.87)
8th Gear									
177.79 (132.58)	16151 (71.84)	4.13 (6.64)	2199	2.23	0.470 (0.286)	15.05 (2.96)	187 (86)	61 (16)	28.90 (97.87)
9th Gear									
178.18 (132.87)	14279 (63.52)	4.68 (7.53)	2199	1.61	0.469 (0.285)	15.08 (2.97)	187 (86)	61 (16)	28.91 (97.90)
10th Gear									
175.96 (131.22)	12445 (55.36)	5.30 (8.53)	2200	1.30	0.474 (0.288)	14.91 (2.94)	189 (87)	60 (16)	28.92 (97.93)
11th Gear									
173.87 (129.65)	10858 (48.30)	6.01 (9.66)	2197	1.06	0.480 (0.292)	14.73 (2.90)	189 (87)	60 (16)	28.92 (97.93)
12th Gear									
172.29 (128.48)	9515 (42.32)	6.79 (10.93)	2198	0.99	0.483 (0.294)	14.64 (2.88)	190 (88)	60 (16)	28.92 (97.93)
13th Gear									
166.62 (124.25)	7210 (32.07)	8.67 (13.95)	2201	0.83	0.503 (0.306)	14.06 (2.77)	190 (88)	60 (16)	28.92 (97.93)

THREE POINT HITCH PERFORMANCE (OECD Static Test)

CATEGORY: III

Quick Attach: yes

Maximum Force Exerted Through Whole Range: 15749 lbs (70.1 kN)

i) Opening pressure of relief valve: NA

Sustained pressure at compensator cutoff:	2900 psi (200 bar)	<u>High flow option</u> 2930 psi (202 bar)
	two outlet sets combined	

ii) Pump delivery rate at minimum pressure and rated engine speed:	34.7 GPM (131.4 l/min)	43.3 GPM (163.9 l/min)
--	------------------------	------------------------

iii) Pump delivery rate at maximum hydraulic power:	32.8 GPM (124.2 l/min)	41.0 GPM (155.2 l/min)
Delivery pressure:	2540 psi (175 bar)	2370 psi (163 bar)
Power:	48.6 HP (36.2 kW)	56.7 HP (42.3 kW)
	single outlet set	

ii) Pump delivery rate at minimum pressure and rated engine speed:	31.4 GPM (118.9 l/min)	32.2 GPM (121.9 l/min)
--	------------------------	------------------------

iii) Pump delivery rate at maximum hydraulic power:	29.9 GPM (113.2 l/min)	27.7 GPM (104.9 l/min)
Delivery pressure:	2200 psi (152 bar)	2250 psi (155 bar)
Power:	38.4 HP (28.6 kW)	36.4 HP (27.1 kW)

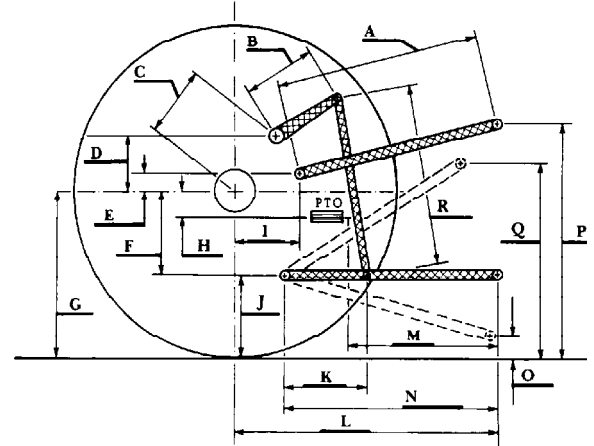

HITCH DIMENSIONS AS TESTED NO LOAD

THREE POINT HITCH PERFORMANCE

Observed Maximum Pressure psi. (bar):	2890 (199)
Location:	lift cylinder
Hydraulic oil temperature: °F (°C):	148 (64)
Location:	hydraulic sump
Category:	III
Quick attach:	yes

SAE Static Test System pressure 2575 psi (177 Bar)

Hitch point distance to ground level in. (mm)	8.0 (203)	16.1 (408)	24.1 (613)	32.1 (814)	40.0 (1016)
Lift force on frame lb	15904	15964	16354	16348	15410
" " " " " " (kN)	(70.7)	(71.0)	(72.8)	(72.7)	(68.6)

ASAE Static Test System pressure 2850 psi (196 Bar)

Hitch point distance to ground level in. (mm)	8.0 (203)	16.1 (408)	24.1 (613)	32.1 (814)	40.0 (1016)
Lift force on frame lb	17671	17634	18059	18053	16981
" " " " " " (kN)	(78.6)	(78.4)	(80.3)	(80.3)	(52.7)

	inch	mm
A	28.9	733
B	19.5	495
C	22.9	582
D	22.2	565
E	10.2	260
F	11.0	280
G	33.6	853
H	3.2	81
I	15.6	395
J	22.6	573
K	28.3	718
L	48.5	1231
*L'	52.0	1320
M	25.5	647
N	41.6	1056
O	8.0	203
P	40.8	1037
Q	39.1	993
R	42.9	1089

*L' to Quick Attach ends



JOHN DEERE 8310T DIESEL

Agricultural Research Division
 Institute of Agriculture and Natural Resources
 University of Nebraska Lincoln
 Darrell Nelson, Dean & Director