

# NEBRASKA OECD TRACTOR TEST 2151 - SUMMARY 1014

## CLAAS XERION 4500 DIESEL

### CONTINUOUSLY VARIABLE TRANSMISSION

#### POWER TAKE-OFF PERFORMANCE

Power HP (kW)	Crank shaft speed rpm	Diesel Consumption		D.E.F. Consumption		Mean Atmospheric Conditions
		Gal/hr (l/h)	lb/hp.hr (kg/kW.h)	Hp.hr/gal (kW.h/l)	Gal/hr (l/h)	
<b>MAXIMUM POWER AND FUEL CONSUMPTION</b>						
<b>Rated Engine Speed—(PTO speed—1098 rpm)</b>						
415.19 (309.61)	1899	22.65 (85.75)	0.382 (0.233)	18.33 (3.61)	0.67 (2.52)	
<b>Standard Power Take-off Speed (1000 rpm)</b>						
437.29 (326.08)	1729	22.85 (86.51)	0.366 (0.223)	19.13 (3.77)	0.65 (2.47)	
<b>Maximum Power (1 hour)</b>						
439.48 (327.72)	1601	22.52 (85.24)	0.359 (0.218)	19.52 (3.84)	0.67 (2.55)	
<b>VARYING POWER AND FUEL CONSUMPTION</b>						
415.19 (309.61)	1899	22.65 (85.75)	0.382 (0.233)	18.33 (3.61)	0.67 (2.52)	Air temperature
353.63 (263.70)	1902	19.77 (74.83)	0.392 (0.238)	17.89 (3.52)	0.53 (2.00)	75°F (24°C)
265.74 (198.16)	1906	15.35 (58.11)	0.405 (0.246)	17.31 (3.41)	0.37 (1.40)	Relative humidity
177.52 (132.37)	1909	11.68 (44.21)	0.461 (0.280)	15.20 (2.99)	0.27 (1.02)	49%
89.01 (66.37)	1913	8.01 (30.31)	0.631 (0.384)	11.11 (2.19)	0.16 (0.61)	Barometer
1.87 (1.39)	1916	4.47 (16.94)	16.798 (10.218)	0.42 (0.08)	0.00 (0.00)	28.54" Hg (96.64 kPa)

Maximum torque - 1547 lb.-ft. (2097 Nm) at 1100 rpm

Maximum torque rise - 34.9%

Torque rise at 1518 engine rpm - 32%

Power increase at 1601 engine rpm - 5.9%

#### DRAWBAR PERFORMANCE

##### FUEL CONSUMPTION CHARACTERISTICS

Power Hp (kW)	Drawbar pull lbs (kN)	Speed mph (km/h)	Crank- shaft speed rpm	Slip %	Fuel Consumption		D.E.F. Consumption	Temp. °F(°C)	Barom. inch Hg (kPa)	
					lb/hp.hr (kg/kW.h)	Hp.hr/gal (kW.h/l)	lb/hp.hr (kg/kW.h)	cool- ing med	Air dry bulb	
<b>Power at Rated Engine Speed—5.6 mph (9.0 km/h)-Manual mode</b>										
375.91 (280.31)	25628 (114.00)	5.50 (8.85)	1841	2.3	0.423 (0.257)	16.58 (3.27)	0.017 (0.011)	187 (86)	60 (16)	28.96 (98.07)
<b>75% of Pull at Rated Engine Speed—5.6 mph (9.0 km/h)-Manual mode</b>										
283.06 (211.07)	19217 (85.48)	5.52 (8.88)	1859	1.7	0.442 (0.269)	15.84 (3.12)	0.017 (0.010)	186 (86)	68 (20)	28.95 (98.04)
<b>50% of Pull at Rated Engine Speed—5.6 mph (9.0 km/h)-Manual mode</b>										
189.67 (141.43)	12802 (56.94)	5.56 (8.95)	1875	1.1	0.492 (0.299)	14.24 (2.81)	0.017 (0.010)	185 (85)	68 (20)	28.93 (97.97)
<b>75% of Pull at Reduced Engine Speed—Auto mode</b>										
283.07 (211.08)	19008 (84.55)	5.59 (8.99)	1309	1.7	0.423 (0.257)	16.58 (3.27)	0.020 (0.012)	187 (86)	69 (20)	28.95 (98.04)
<b>50% of Pull at Reduced Engine Speed—Auto mode</b>										
189.83 (141.56)	12743 (56.68)	5.59 (8.99)	1268	1.1	0.445 (0.270)	15.76 (3.10)	0.021 (0.013)	186 (85)	69 (20)	28.91 (97.90)

**Location of tests:** Nebraska Tractor Test Laboratory, University of Nebraska, Lincoln, Nebraska 68583-0832

**Dates of tests:** May 10 - 19, 2016

**Manufacturer:** CLAAS Selbstfahrende Erntemaschinen GmbH, 33428 Harsewinkel, Germany

**CONSUMABLE Fluids, OIL and TIME: Fuel** No. 2 Diesel **Specific gravity converted to 60°/60°F (15°/15°C)** 0.8417 **Fuel weight** 7.008 lbs/gal (0.840 kg/l) **Diesel Exhaust Fluid (DEF)** 32% aqueous urea solution **DEF weight** 9.071 lbs/gal (1.087 kg/l) **Oil SAE 10W40 API service classification** CJ-4 **Transmission lubricant** Agrishift XE fluid **Hydraulics, front and rear axle lubricant** Claas Agrihyd HVLDPD fluid **Final drive lubricant** MT 80W-90 API GL5 **Total time engine was operated:** 28.5 hours

**ENGINE: Make** Mercedes-Benz **Diesel Type** six cylinder vertical with turbocharger, air to air intercooler and D.E.F. (diesel exhaust fluid) exhaust treatment **Serial No.** 471.919-C-0155467 **Crankshaft** lengthwise **Rated engine speed** 1900 **Bore and stroke** 5.197" x 6.142" (132.0 mm x 156.0 mm) **Compression ratio** 17.3 to 1 **Displacement** 781 cu in (12810 ml) **Starting system** 24 volt **Lubrication** pressure **Air cleaner** two paper elements and aspirator **Oil filter** one full flow cartridge **Oil cooler** engine coolant heat exchanger for crankcase oil, separate radiators for hydraulic, transmission, front axle and rear axle oils **Fuel filter** two paper elements **Exhaust** DOC (diesel oxidation catalyst) and SCR (selective catalyst reduction) within a horizontal muffler with vertical outlet **Cooling medium temperature control** thermostat and variable speed fan

**ENGINE OPERATING PARAMETERS: Fuel rate:** 156.1 - 162.5 lb/h (70.8 - 73.7 kg/h) **High idle:** 1910 - 1930 rpm (Drawbar operations - 1850 - 1890 rpm) **Turbo boost:** nominal 30.5 - 34.1 psi (210 - 235 kPa) as measured 32.3 psi (223 kPa)

**CHASSIS: Type** rigid frame four wheel drive with duals **Serial No.** \*78300306\* **Tread width** rear 89.2" (2265 mm) and 159.8" (4060 mm) front 89.2" (2265 mm) and 159.8" (4060 mm) **Wheelbase** 141.7" (3600 mm) **Hydraulic control system** direct engine drive **Transmission** Infinitely variable with four mechanical ranges and automatic shifting between ranges **Nominal travel speeds mph (km/h)** forward - 0 - 31 mph, (0 - 50 km/h) reverse - 0 - 31 mph (0 - 50 km/h) **Clutch** a foot pedal controls the hydrostatic oil flow **Brakes** wet disc hydraulically operated by foot pedal **Steering** electro-hydraulic with the ability to steer front and rear axles independently or coordinated

**DRAWBAR PERFORMANCE AT  
1840 ENGINE RPM-MANUAL MODE  
DRAWBAR POWER AT SELECTED TRAVEL SPEEDS**

Power Hp (kW)	Drawbar pull lbs (kN)	Speed mph (km/h)	Crank- shaft speed rpm	Slip %	Fuel Consumption lb/hp.hr (kg/kW.h)	D.E.F Consumption Hp.hr/gal (kW.h/l)	Temp. °F(°C) cool- ing med	Air dry bulb	Barom. inch Hg (kPa)	
2.5 mph (4.0 km/h)										
267.04 (199.13)	45247 (201.27)	2.22 (3.56)	1854	11.9	0.508 (0.309)	13.81 (2.72)	0.017 (0.010)	186 (86)	65 (18)	28.71 (97.22)
3.1 mph (5.0 km/h)										
332.36 (247.84)	43538 (193.66)	2.86 (4.60)	1841	7.7	0.480 (0.292)	14.60 (2.88)	0.018 (0.011)	187 (86)	67 (20)	28.70 (97.17)
3.7 mph (6.0 km/h)										
345.61 (257.72)	36284 (161.40)	3.57 (5.75)	1840	4.4	0.463 (0.282)	15.13 (2.98)	0.018 (0.011)	187 (86)	69 (21)	28.72 (97.26)
4.2 mph (6.8 km/h)										
357.06 (266.26)	32513 (144.62)	4.12 (6.63)	1841	3.8	0.448 (0.273)	15.64 (3.08)	0.017 (0.010)	187 (86)	73 (23)	28.67 (97.09)
4.7 mph (7.5 km/h)										
367.88 (274.32)	30515 (135.74)	4.52 (7.27)	1841	3.2	0.435 (0.264)	16.12 (3.18)	0.017 (0.011)	187 (86)	60 (16)	28.95 (98.04)
5.1 mph (8.2 km/h)										
371.65 (277.14)	28581 (127.13)	4.88 (7.85)	1841	2.7	0.428 (0.260)	16.39 (3.23)	0.017 (0.011)	187 (86)	60 (16)	28.93 (97.97)
5.6 mph (9.0 km/h)										
375.91 (280.31)	25628 (114.00)	5.50 (8.85)	1841	2.3	0.423 (0.257)	16.58 (3.27)	0.017 (0.011)	187 (86)	60 (16)	28.96 (98.06)
6.2 mph (10.0 km/h)										
373.71 (278.67)	23614 (105.04)	5.94 (9.55)	1840	2.0	0.427 (0.260)	16.42 (3.23)	0.017 (0.011)	187 (86)	61 (16)	28.97 (98.10)
6.8 mph (11.0 km/h)										
368.11 (274.50)	20683 (92.00)	6.67 (10.73)	1841	1.8	0.431 (0.262)	16.24 (3.20)	0.018 (0.011)	188 (87)	62 (17)	28.93 (97.97)
7.5 mph (12.0 km/h)										
363.41 (270.99)	18557 (82.54)	7.35 (11.82)	1840	1.7	0.437 (0.266)	16.05 (3.16)	0.018 (0.011)	188 (87)	63 (17)	28.97 (98.10)
8.1 mph (13.0 km/h)										
355.81 (263.32)	17014 (75.68)	7.84 (12.62)	1839	1.6	0.446 (0.271)	15.73 (3.10)	0.018 (0.011)	188 (87)	64 (18)	28.94 (98.00)
8.7 mph (14.0 km/h)										
357.67 (266.71)	15594 (69.36)	8.61 (13.85)	1840	1.5	0.443 (0.270)	15.81 (3.11)	0.018 (0.011)	188 (87)	65 (18)	28.95 (98.04)

**Power take-off** 1000 rpm at 1730 engine rpm  
**Unladen tractor mass** 43150 lb (19572 kg)

**REPAIRS AND ADJUSTMENTS:** No repairs or adjustments.

**NOTE:** To facilitate drawbar testing, the tractor was equipped with computer software that locked the transmission into the speed settings shown. These runs are denoted as Manual mode.

**REMARKS:** All test results were determined from observed data obtained in accordance with official OECD, SAE and Nebraska test procedures. This tractor did not meet the manufacturer's 3 point lift claim of 22480 lb (100 kN) nor remote hydraulic flow of 51.5 GPM (195 l/min) with standard pump. The manufacturer's remote hydraulic flow claim of 72.5 GPM (275 l/min) with "twin priority" pump was not verified. The performance figures on this Summary were taken from a test conducted under the OECD Code 2 test procedure.

We, the undersigned, certify that this is a true and correct report of official Tractor Test No. **2151**, Nebraska Summary 1014, June 10, 2016.

Roger M. Hoy  
Director

M.F. Kocher  
J.D. Luck  
P.J. Jasa  
Board of Tractor Test Engineers

TRACTOR SOUND LEVEL WITH CAB	dB(A)
At no load at 4.7 mph (7.5 km/h) engine speed 1905 rpm	69.7
At no load at 4.7 mph (7.5 km/h) engine speed 1220 rpm	68.5
Bystander	89.1

TIRES, BALLAST AND WEIGHT	With Ballast	Without Ballast
<b>Rear Tires</b> - No., size, ply & psi(kPa)	Four 710/70R42;***;13(90)	Four 710/70R42;***;10(70)
<b>Ballast</b> - Liquid (total)	None	None
- Cast Iron (center total)	3145 lb (1427 kg)	None
<b>Front Tires</b> - No., size, ply & psi(kPa)	Four 710/70R42;***;11(75)	Four 710/70R42;***;9(60)
<b>Ballast</b> - Cast iron(front end)(total)	4930 lb (2236 kg)	None
- Liquid (total)	None	None
<b>Height of Drawbar</b>	23.0 in (585 mm)	22.5 in (570 mm)
<b>Static Weight with operator</b> - Rear	20165 lb (9146 kg)	20340 lb (9226 kg)
- Front	31235 lb(14168 kg)	22985 lb(10425 kg)
- Total	51400 lb(23314 kg)	43325 lb(19651 kg)

## DRAWBAR PERFORMANCE - AUTO MODE

(Loads based on 1840 engine rpm manual mode performance runs)

### DRAWBAR POWER AT SELECTED TRAVEL SPEEDS

Power Hp (kW)	Drawbar pull lbs (kN)	Speed mph (km/h)	Crank- shaft speed rpm	Slip %	Fuel Consumption lb/hp.hr (kg/kW.h)	Hp.hr/gal (kW.h/l)	D.E.F Consumption lb/hp.hr (kg/kW.h)	Temp. °F(°C) cool- ing med	Air dry bulb	Barom. inch Hg (kPa)
4.2 mph (6.8 km/h)										
355.12 (264.81)	32394 (144.10)	4.12 (6.62)	1423	3.7	0.407 (0.248)	17.22 (3.39)	0.019 (0.012)	188 (87)	66 (19)	28.76 (97.39)
4.7 mph (7.5 km/h)										
368.74 (274.97)	30520 (135.76)	4.54 (7.30)	1472	3.2	0.407 (0.248)	17.22 (3.39)	0.018 (0.011)	189 (87)	67 (19)	28.79 (97.49)
5.5 mph (8.8 km/h)										
370.54 (276.31)	28517 (126.85)	4.87 (7.84)	1496	2.8	0.414 (0.252)	16.94 (3.34)	0.016 (0.010)	189 (87)	76 (25)	28.69 (97.16)
6.0 mph (9.6 km/h)										
371.82 (277.26)	25602 (113.88)	5.45 (8.76)	1474	2.4	0.407 (0.248)	17.21 (3.39)	0.019 (0.011)	189 (87)	62 (17)	28.86 (97.73)
6.6 mph (10.6 km/h)										
369.54 (275.56)	23945 (106.51)	5.79 (9.32)	1475	2.1	0.409 (0.249)	17.12 (3.37)	0.019 (0.011)	189 (87)	64 (18)	28.79 (97.49)
7.3 mph (11.8 km/h)										
359.66 (268.20)	20634 (91.78)	6.54 (10.52)	1501	1.9	0.427 (0.260)	16.40 (3.23)	0.019 (0.011)	189 (87)	73 (23)	28.70 (97.19)
8.0 mph (12.8 km/h)										
366.14 (273.03)	18554 (82.53)	7.40 (11.91)	1479	1.7	0.415 (0.252)	16.89 (3.33)	0.018 (0.011)	190 (88)	72 (22)	28.70 (97.19)
8.2 mph (13.2 km/h)										
353.11 (263.31)	17008 (75.66)	7.79 (12.53)	1402	1.6	0.404 (0.246)	17.33 (3.41)	0.019 (0.012)	189 (87)	71 (21)	28.73 (97.29)
9.1 mph (14.6 km/h)										
355.85 (265.35)	15645 (69.59)	8.53 (13.73)	1402	1.5	0.404 (0.246)	17.34 (3.42)	0.019 (0.011)	189 (87)	70 (21)	28.76 (97.39)

**DRAWBAR PERFORMANCE AT  
1600 ENGINE RPM-MANUAL MODE-UNBALLASTED  
MAXIMUM POWER AT SELECTED TRAVEL SPEEDS**

Power Hp (kW)	Drawbar pull lbs (kN)	Speed mph (km/h)	Crank- shaft speed rpm	Slip %	Fuel Consumption lb/hp.hr (kg/kW.h)	Hp.hr/gal (kW.h/l)	D.E.F Consumption lb/hp.hr (kg/kW.h)	Temp. °F(°C) cool- ing med	Air dry bulb	Barom. inch Hg (kPa)
2.5 mph (4.0 km/h)										
268.68 (200.35)	44905 (199.75)	2.25 (3.61)	1855	12.3	0.500 (0.304)	14.01 (2.76)	0.017 (0.010)	186 (86)	65 (18)	28.70 (97.19)
3.1 mph (5.0 km/h)										
333.74 (248.87)	43801 (194.84)	2.86 (4.60)	1841	7.8	0.480 (0.292)	14.59 (2.87)	0.018 (0.011)	187 (86)	68 (20)	28.71 (97.22)
3.7 mph (6.0 km/h)										
348.08 (259.56)	40465 (180.00)	3.23 (5.19)	1685	5.4	0.459 (0.279)	15.27 (3.01)	0.018 (0.011)	187 (86)	70 (21)	28.69 (97.16)
4.2 mph (6.8 km/h)										
361.69 (269.71)	38435 (170.97)	3.53 (5.68)	1600	4.8	0.435 (0.265)	16.10 (3.17)	0.017 (0.011)	188 (86)	72 (22)	28.69 (97.16)
4.7 mph (7.5 km/h)										
367.43 (273.99)	35650 (158.58)	3.87 (6.22)	1600	4.2	0.428 (0.261)	16.36 (3.22)	0.017 (0.011)	188 (87)	74 (24)	28.63 (96.95)
5.1 mph (8.2 km/h)										
374.88 (279.54)	32525 (144.68)	4.33 (6.96)	1600	3.6	0.420 (0.256)	16.67 (3.28)	0.017 (0.010)	188 (87)	73 (23)	28.67 (97.09)
5.6 mph (9.0 km/h)										
382.39 (285.15)	30539 (135.84)	4.70 (7.56)	1600	3.0	0.412 (0.250)	17.02 (3.35)	0.018 (0.011)	188 (86)	67 (19)	28.94 (98.00)
6.2 mph (10.0 km/h)										
382.33 (285.10)	27011 (120.15)	5.31 (8.55)	1600	2.5	0.414 (0.252)	16.95 (3.34)	0.018 (0.011)	187 (86)	64 (18)	28.97 (98.10)
6.8 mph (11.0 km/h)										
382.05 (284.89)	24864 (110.60)	5.76 (9.27)	1600	2.2	0.412 (0.251)	17.00 (3.35)	0.018 (0.011)	188 (86)	64 (18)	28.94 (98.00)
7.5 mph (12.0 km/h)										
378.29 (282.09)	22549 (100.30)	6.29 (10.12)	1599	1.9	0.417 (0.254)	16.82 (3.31)	0.018 (0.011)	188 (86)	62 (17)	28.97 (98.10)
8.1 mph (13.0 km/h)										
365.77 (272.75)	20338 (90.47)	6.75 (10.86)	1600	1.8	0.431 (0.262)	16.27 (3.20)	0.017 (0.010)	188 (87)	75 (24)	28.68 (97.12)
8.7 mph (14.0 km/h)										
370.80 (276.50)	18649 (82.95)	7.46 (12.00)	1600	1.6	0.426 (0.259)	16.47 (3.24)	0.019 (0.011)	188 (87)	65 (18)	28.94 (98.00)
9.3 mph (15.0 km/h)										
377.29 (281.35)	17252 (76.74)	8.20 (13.20)	1599	1.5	0.417 (0.254)	16.79 (3.31)	0.018 (0.011)	188 (87)	65 (18)	28.95 (98.04)

**DRAWBAR PERFORMANCE AT  
1600 ENGINE RPM-MANUAL MODE-BALLASTED  
MAXIMUM POWER AT SELECTED TRAVEL SPEEDS**

Power Hp (kW)	Drawbar pull lbs (kN)	Speed mph (km/h)	Crank- shaft speed rpm	Slip %	Fuel Consumption lb/hp.hr (kg/kW.h)	Hp.hr/gal (kW.h/l)	D.E.F Consumption lb/hp.hr (kg/kW.h)	Temp. °F(°C) cool- ing med	Air dry bulb	Barom. inch Hg (kPa)
2.5 mph (4.0 km/h)										
311.16 (232.03)	53975 (240.09)	2.17 (3.48)	1834	12.3	0.515 (0.313)	13.60 (2.68)	0.019 (0.011)	187 (86)	56 (13)	28.97 (98.10)
3.1 mph (5.0 km/h)										
344.71 (257.05)	49322 (219.40)	2.62 (4.22)	1640	7.5	0.462 (0.281)	15.18 (2.99)	0.018 (0.011)	188 (86)	58 (14)	28.98 (98.14)
3.7 mph (6.0 km/h)										
357.10 (266.29)	43691 (194.34)	3.07 (4.93)	1600	4.6	0.444 (0.270)	15.77 (3.11)	0.018 (0.011)	188 (87)	59 (15)	29.00 (98.21)
4.2 mph (6.8 km/h)										
368.68 (274.92)	39683 (176.52)	3.48 (5.60)	1600	4.1	0.428 (0.260)	16.38 (3.23)	0.017 (0.010)	187 (86)	61 (16)	28.96 (98.07)
4.7 mph (7.5 km/h)										
375.91 (280.31)	36486 (162.30)	3.86 (6.21)	1599	3.6	0.420 (0.255)	16.69 (3.29)	0.017 (0.010)	188 (87)	61 (16)	28.99 (98.17)
5.1 mph (8.2 km/h)										
380.99 (284.10)	33973 (151.12)	4.21 (6.78)	1600	3.2	0.415 (0.252)	16.90 (3.33)	0.017 (0.010)	188 (87)	62 (17)	28.98 (98.14)
5.6 mph (9.0 km/h)										
384.93 (287.04)	31234 (138.94)	4.62 (7.44)	1600	2.8	0.409 (0.249)	17.15 (3.38)	0.017 (0.010)	187 (86)	63 (17)	28.98 (98.14)
6.2 mph (10.0 km/h)										
383.17 (285.73)	27404 (121.90)	5.24 (8.43)	1600	2.4	0.411 (0.250)	17.05 (3.36)	0.016 (0.010)	188 (86)	64 (18)	28.99 (98.17)
6.8 mph (11.0 km/h)										
381.11 (284.19)	24745 (110.07)	5.78 (9.30)	1599	2.0	0.415 (0.252)	16.90 (3.33)	0.017 (0.010)	187 (86)	65 (18)	28.99 (98.17)
7.5 mph (12.0 km/h)										
377.42 (281.44)	22114 (98.37)	6.40 (10.30)	1601	1.7	0.417 (0.253)	16.82 (3.31)	0.017 (0.010)	188 (87)	65 (18)	28.97 (98.10)
8.1 mph (13.0 km/h)										
371.53 (277.05)	20539 (91.36)	6.78 (10.91)	1599	1.6	0.424 (0.258)	16.53 (3.26)	0.017 (0.010)	188 (87)	65 (19)	28.99 (98.17)
8.7 mph (14.0 km/h)										
371.52 (277.04)	18588 (82.68)	7.50 (12.07)	1600	1.5	0.424 (0.258)	16.54 (3.26)	0.018 (0.011)	188 (86)	66 (19)	28.98 (98.14)
9.3 mph (15.0 km/h)										
375.97 (280.36)	17143 (76.25)	8.23 (13.24)	1600	1.3	0.420 (0.255)	16.70 (3.29)	0.017 (0.010)	188 (86)	66 (19)	28.97 (98.10)

## HYDRAULIC PERFORMANCE

CATEGORY: IVN

Quick Attach: yes

OECD Static test

Maximum force exerted through whole range: 21739 lbs (96.7 kN)

**Two outlet sets combined**

Standard pump

i) Sustained pressure of the open relief valve: 2808 psi (194 bar)

ii) Pump delivery rate at minimum pressure and rated engine speed: 50.3 GPM (190.6 l/min)

iii) Pump delivery rate at maximum hydraulic power: 47.3 GPM (179.1 l/min)

Delivery pressure: 2592 psi (179 bar)

Power: 71.6 HP (53.4 kW)

**Single outlet set**

ii) Pump delivery rate at minimum pressure and rated engine speed: 30.4 GPM (115.1 l/min)

iii) Pump delivery rate at maximum hydraulic power: 29.3 GPM (111.0 l/min)

Delivery pressure: 2420 psi (167 bar)

Power: 41.4 HP (30.9 kW)

## HITCH DIMENSIONS AS TESTED - NO LOAD

	inch	mm
A	31.9	810
B	23.6	600
C	19.2	487
D	18.8	478
E	11.0	279
F	16.6	422
G	37.6	955
H	0.2	5
I	25.5	647
J	21.0	533
K	22.8	578
L	57.4	1458
*L'	63.7	1618
M	30.4	773
N	41.9	1065
O	9.1	230
P	49.0	1244
Q	38.6	980
R	44.1	1120

\*L' to Quick Attach ends

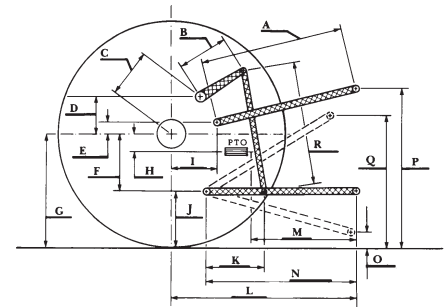

### CLAAS XERION 4500 Diesel

Institute of Agriculture and Natural Resources  
University of Nebraska-Lincoln