

NEBRASKA TRACTOR TEST 1781C CHALLENGER MT 635 DIESEL 18 SPEED

POWER TAKE-OFF PERFORMANCE

Power HP (kW)	Crank shaft speed rpm	Gal/hr (l/h)	lb/hp.hr (kg/kW.h)	Hp.hr/gal (kW.h/l)	Mean Atmospheric Conditions
MAXIMUM POWER AND FUEL CONSUMPTION					
Rated Engine Speed—(PTO speed—1052 rpm)					
164.45 (122.63)	2200	10.24 (38.76)	0.438 (0.266)	16.06 (3.16)	
Standard Power Take-off Speed (1000 rpm)					
171.41 (127.82)	2092	10.19 (38.59)	0.418 (0.254)	16.82 (3.31)	
Maximum Power (2 Hours)					
174.62 (130.21)	1950	9.88 (37.42)	0.398 (0.242)	17.67 (3.48)	

VARYING POWER AND FUEL CONSUMPTION

164.45 (122.63)	2200	10.24 (38.76)	0.438 (0.266)	16.06 (3.16)	Air temperature
144.09 (107.45)	2269	9.48 (35.87)	0.462 (0.281)	15.21 (3.00)	76°F (25°C)
109.03 (81.31)	2293	7.90 (29.89)	0.509 (0.310)	13.81 (2.72)	Relative humidity
73.61 (54.89)	2317	6.27 (23.75)	0.599 (0.364)	11.73 (2.31)	31%
37.04 (27.62)	2338	4.74 (17.94)	0.899 (0.547)	7.82 (1.54)	Barometer
1.08 (0.80)	2367	3.12 (11.80)	20.322 (12.361)	0.35 (0.07)	29.16" Hg (98.75 kPa)

Maximum Torque - 561 lb.-ft. (761 Nm) at 1350 rpm
Maximum Torque Rise - 43.0%
Torque rise at 1800 engine rpm - 27%

TRACTOR SOUND LEVEL WITH CAB	Front Wheel Drive	
	Engaged dB(A)	Disengaged dB(A)
At no load in 9th gear	73.8	73.5
Bystander	--	--

TIRES AND WEIGHT

Rear tires - No., size, ply & psi (kPa)
Front tires - No., size, ply & psi (kPa)
Height of Drawbar
Static Weight with operator- Rear
- Front
- Total

Tested Without Ballast
Two 18.4R42; **; 22 (150)
Two 14.9R30; **; 24 (165)
16.0 in (405 mm)
12235 lb (5550 kg)
6740 lb (3057 kg)
18975 lb (8607 kg)

Location of Test: Nebraska Tractor Test Laboratory, University of Nebraska, Lincoln Nebraska, 68583-0832

Dates of Test: September 15-26, 2000

Manufacturer: AGCO Corporation, 4205 River Green Parkway, Duluth Ga. 30096-2568 USA

FUEL and OIL: Fuel No. 2 Diesel **Specific gravity converted to 60°/60°F (15°/15°C)** 0.8441 **Fuel weight** 7.028 lbs/gal (0.842 kg/l) **Oil SAE 15W40 API service classification** CD/CF-4 **Transmission and hydraulic lubricant** AGCO Power fluid 821 XL **Front axle lubricant** AGCO Gear Lube 715 **Total time engine was operated** 8.0 hours

ENGINE: Make Sisu/Valmet Diesel **Type** six cylinder vertical with turbocharger and intercooler **Serial No.** H18085 **Crankshaft** lengthwise **Rated engine speed** 2200 **Bore and stroke** 4.251" x 5.278" (108.0 mm x 134.0 mm) **Compression ratio** 16.5 to 1 **Displacement** 449 cu in (7365 ml) **Starting system** 12 volt **Lubrication** pressure **Air cleaner** two paper elements and aspirator **Oil filter** one full flow cartridge **Oil cooler** engine coolant heat exchanger for crankcase oil, radiator for hydraulic and transmission oil **Fuel filter** two paper elements **Muffler** vertical **Cooling medium temperature control** thermostat and variable speed fan

ENGINE OPERATING PARAMETERS:
Fuel rate: 71.9 - 77.9 lb/h (32.6 - 35.3 kg/h) **High idle:** 2304 - 2404 rpm **Turbo boost:** nominal 16.0 - 24.0 psi (110 - 165 kPa) as measured 22.6 psi (156 kPa)

CHASSIS: **Type** front wheel assist **Serial No.** *CH245003 ***Tread width** rear 61.5" (1562 mm) to 126.0" (3200 mm) front 59.9" (1522 mm) to 87.9" (2233 mm) **Wheelbase** 121.1" (3075 mm) **Hydraulic control system** direct engine drive **Transmission** selective gear fixed ratio with full range operator controlled powershift **Nominal travel speeds mph (km/h)** first 1.36 (2.19) second 1.76 (2.83) third 2.27 (3.65) fourth 2.59 (4.17) fifth 2.92 (4.70) sixth 3.33 (5.36) seventh 3.78 (6.09) eighth 4.31 (6.94) ninth 4.88 (7.85) tenth 5.56 (8.95) eleventh 6.31 (10.16) twelfth 7.20 (11.58) thirteenth 8.13 (13.09) fourteenth 9.26 (14.91) fifteenth 10.53 (16.94) sixteenth 13.56 (21.82) seventeenth 17.54 (28.23) eighteenth 22.60 (36.37) reverse 1.36 (2.19), 2.27 (3.65), 2.59 (4.17), 3.78 (6.09), 4.31 (6.94), 6.31 (10.16) **Clutch** multiple wet disc electro-hydraulically operated by foot pedal **Brakes** multiple wet disc hydraulically operated by two foot pedals that can be locked together **Steering** hydrostatic **Power take-off** 540 rpm at 1991 engine rpm or 1000 rpm at 2091 engine rpm **Unladen tractor mass** 18800 lb (8165 kg)

THREE POINT HITCH PERFORMANCE (OECD Static Test)

CATEGORY: III

Quick Attach: None

Maximum Force Exerted

Through Whole Range: 16101 lbs (71.6 kN)

		<u>High flow option</u>
i) Opening pressure of relief valve:	NA	NA
Sustained pressure of the open relief valve:	2860 psi (197 bar)	2850 psi (196 bar)
ii) Pump delivery rate at minimum pressure and rated engine speed:	29.7 GPM (112.4 l/min)	39.3 GPM (148.8 l/min)
iii) Pump delivery rate at maximum hydraulic power:	22.7 GPM (85.9 l/min)	35.9 GPM (135.9 l/min)
Delivery pressure:	2690 psi (185 bar)	2490 psi (172 bar)
Power:	35.6 HP (26.6 kW)	52.2 Hp (38.9 kW)

REPAIRS AND ADJUSTMENTS: No repairs or adjustments

REMARKS: All test results were determined from observed data obtained in accordance with official OECD, SAE and Nebraska test procedures. For the maximum power tests the fuel temperature at the injection pump inlet was maintained at 129°F (54°C).

NOTE: The data on this report was obtained from Nebraska test 1781B conducted on the Massey Ferguson 8245 Diesel.

THREE POINT HITCH PERFORMANCE

Observed Maximum Pressure psi.(bar)	3015(208)
Location:	lift cylinder
Hydraulic oil temperature: °F(°C)	153(67)
Location:	hydraulic sump
Category:	III
Quick attach:	none

SAE Static Test—System pressure 2715 psi (187 Bar)

Hitch point distance to ground level in.(mm)	9.7(246)	16.0(406)	24.0(610)	32.0(813)	40.0(1016)
Lift force on frame lb	18963	18432	18441	18054	16965
" " " " " " (kN)	(84.4)	(82.0)	(82.0)	(80.3)	(75.5)

Report reissued: Supplemental sales permit for Challenger MT 635 Diesel, July 2003.

We, the undersigned, certify that this is a true and correct report of Official Tractor Test No. **1781C**, June 26, 2003.

Leonard L. Bashford
Director

M.F. Kocher
W.P. Campbell
G.J. Hoffman
Board of Tractor Test Engineers

	SAE TEST		OECD TEST	
	inch	mm	inch	mm
A	28.8	732	29.8	756
B	15.0	380	15.0	380
C	19.4	492	19.4	492
D	17.6	447	17.6	447
E	11.0	280	11.0	280
F	13.0	330	13.0	330
G	34.3	870	34.3	870
H	3.9	100	3.9	100
I	17.6	447	17.6	447
J	21.3	540	21.3	540
K	21.3	540	23.2	590
L	48.2	1225	48.2	1225
M	23.1	588	23.1	588
N	38.4	975	38.4	975
O	9.6	245	9.3	235
P	43.3	1100	48.2	1225
Q	39.5	1004	37.4	949
R	34.0	864	35.1	892

HITCH DIMENSIONS AS TESTED—NO LOAD

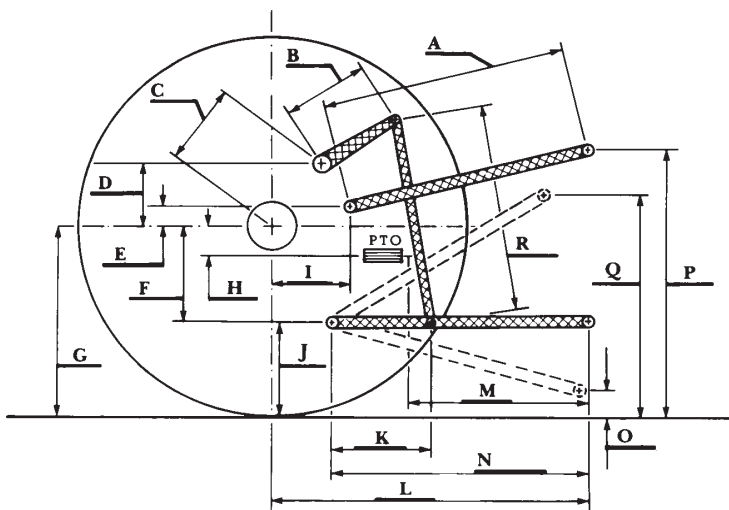

Agricultural Research Division
Institute of Agriculture and Natural Resources
University of Nebraska—Lincoln
Edna McBreen, Interim Vice Chancellor