

# NEBRASKA OECD TRACTOR TEST 2157—SUMMARY 1038

## CASE IH FARMALL 120A DIESEL

### 16 SPEED

Chassis serial numbers CT00001M and higher

#### POWER TAKE-OFF PERFORMANCE

Power HP (kW)	Crank shaft speed rpm	Diesel Consumption		D.E.F. Consumption		Mean Atmospheric Conditions
		Gal/hr (l/h)	lb/hp.hr (kg/kW.h)	Hp.hr/gal (kW.l/l)	Gal/hr (l/h)	
<b>MAXIMUM POWER AND FUEL CONSUMPTION</b>						
<b>Rated Engine Speed—(PTO speed—628 rpm)</b>						
102.55 (76.47)	2201	6.40 (24.23)	0.438 (0.266)	16.02 (3.16)	0.40 (1.52)	
<b>Standard Power Take-off Speed (540 rpm)</b>						
104.24 (77.74)	1890	5.94 (22.48)	0.399 (0.243)	17.56 (3.46)	0.38 (1.42)	
<b>Power at 1850 engine rpm (1 hour)</b>						
104.18 (77.68)	1851	5.86 (22.19)	0.394 (0.240)	17.77 (3.50)	0.39 (1.46)	

#### VARYING POWER AND FUEL CONSUMPTION

102.55 (76.47)	2201	6.40 (24.23)	0.438 (0.266)	16.02 (3.16)	0.40 (1.52)	Air temperature
88.78 (66.20)	2238	5.94 (22.47)	0.469 (0.285)	14.96 (2.95)	0.35 (1.33)	82°F (28°C)
67.59 (50.40)	2268	4.86 (18.40)	0.504 (0.307)	13.91 (2.74)	0.27 (1.01)	Relative humidity
45.61 (34.01)	2298	3.93 (14.86)	0.603 (0.367)	11.62 (2.29)	0.19 (0.71)	71%
23.09 (17.22)	2324	3.19 (12.06)	0.968 (0.589)	7.24 (1.43)	0.13 (0.50)	Barometer
0.91 (0.68)	2348	2.27 (8.59)	17.557 (10.680)	0.40 (0.08)	0.07 (0.28)	28.66" Hg (97.06 kPa)

Maximum torque - 366 lb.-ft. (496 Nm) at 1249 rpm

Maximum torque rise - 49.5%

Torque rise at 1760 engine rpm - 27%

Power increase at 1851 engine rpm - 1.6%

#### DRAWBAR PERFORMANCE

##### UNBALLASTED - FRONT DRIVE ENGAGED

##### FUEL CONSUMPTION CHARACTERISTICS

Power Hp (kW)	Drawbar pull lbs (kN)	Speed mph (km/h)	Crank- shaft speed rpm	Slip %	Fuel Consumption lb/hp.hr (kg/kW.h)	D.E.F. Consumption lb/hp.hr (kg/kW.h)	Temp. °F(°C) cool- ing dry med bulb	Barom. inch Hg (kPa)
<b>Power at Rated Engine Speed—8th (L4R) Gear</b>								
87.99 (65.61)	6814 (30.31)	4.84 (7.79)	2200	7.7	0.510 (0.310)	13.75 (2.71)	0.042 (0.026)	183 (84) 72 (22) 28.72 (97.26)
<b>75% of Pull at Rated Engine Speed—8th (L4R) Gear</b>								
69.29 (51.67)	5097 (22.67)	5.10 (8.21)	2249	5.0	0.550 (0.335)	12.75 (2.51)	0.045 (0.028)	183 (84) 81 (27) 28.68 (97.12)
<b>50% of Pull at Rated Engine Speed—8th (L4R) Gear</b>								
48.03 (35.82)	3406 (15.15)	5.29 (8.51)	2283	2.9	0.643 (0.391)	10.89 (2.15)	0.052 (0.032)	183 (84) 82 (28) 28.68 (97.12)
<b>75% of Pull at Reduced Engine Speed—10th (H1R) Gear</b>								
69.62 (51.91)	5132 (22.83)	5.09 (8.19)	1766	5.1	0.457 (0.278)	15.34 (3.02)	0.042 (0.025)	182 (83) 83 (28) 28.65 (97.02)
<b>50% of Pull at Reduced Engine Speed—10th (H1R) Gear</b>								
48.19 (35.94)	3413 (15.18)	5.30 (8.52)	1798	2.9	0.512 (0.311)	13.70 (2.70)	0.043 (0.026)	181 (83) 82 (28) 28.67 (97.09)

**Location of tests:** Nebraska Tractor Test Laboratory, University of Nebraska, Lincoln Nebraska 68583-0832

**Dates of tests:** September 7 - 9, 2016

**Manufacturer:** CNH De Mexico, Queretaro Mexico

**CONSUMABLE Fluids, OIL and TIME: Fuel** No. 2 Diesel **Specific gravity converted to 60°/60°F (15°/15°C)** 0.8418 **Fuel weight** 7.009 lbs/gal (0.840 kg/l) **Diesel Exhaust Fluid (DEF)** 32% aqueous urea solution **DEF weight** 9.071 lbs/gal (1.087 kg/l) **Oil SAE 10W30 API service classification CJ-4 Transmission, hydraulic and front axle lubricant** Case IH Akcela Nexplore fluid **Total time engine was operated** 16.0 hours

**ENGINE: Make F.P.T NEF Diesel Type** Four cylinder vertical with turbocharger, air to air intercooler and D.E.F. (diesel exhaust fluid) exhaust treatment. **Serial No.** 001387400 **Crankshaft** lengthwise **Rated engine speed** 2200 **Bore and stroke** 4.094" x 5.197" (104.0 mm x 132.0 mm) **Compression ratio** 17.0 to 1 **Displacement** 274 cu in (4485 ml) **Starting system** 12 volt **Lubrication** pressure **Air cleaner** two paper elements **Oil filter** one full flow cartridge **Oil cooler** engine coolant heat exchanger for crankcase oil, radiator for hydraulic and transmission oil **Fuel filter** one paper element **Exhaust** DOC (diesel oxidation catalyst) and SCR (selective catalyst reduction) integrated within a vertical muffler **Cooling medium temperature control** one thermostat

**ENGINE OPERATING PARAMETERS: Fuel rate:** 41.6 - 45.2 lb/h (18.9 - 20.5 kg/h) **High idle:** 2325 - 2375 rpm **Turbo boost:** nominal 16.7- 18.9 psi (115 - 130 kPa) as measured 17.9 psi (123 kPa)

**CHASSIS: Type** front wheel assist **Serial No.** CT00675M **Tread width** rear 64.0" (1625 mm) to 78.0" (1981 mm) front 60.8" (1544 mm) to 88.1" (2240 mm) **Wheelbase** 99.3" (2521 mm) **Hydraulic control system** direct engine drive **Transmission** selective gear fixed ratio with partial (2) range operator controlled powershift **Nominal travel speeds mph (km/h)** first 1.45 (2.33) second 1.77 (2.85) third 2.22 (3.58) fourth 2.73 (4.39) fifth 3.02 (4.86) sixth 3.70 (5.96) seventh 4.19 (6.75) eighth 5.15 (8.28) ninth 5.33 (8.58) tenth 6.54 (10.52) eleventh 8.21 (13.22) twelfth 10.01 (16.20) thirteenth 11.15 (17.94) fourteenth 13.66 (21.99) fifteenth 15.49 (24.92) sixteenth 18.98 (30.54) reverse 1.83 (2.95), 2.82 (4.54), 3.83 (6.16), 5.32 (8.56), 6.76 (10.88), 10.41 (16.75), 14.13 (22.74), 19.62 (31.58) **Clutch** single dry disc operated by foot pedal **Brakes** single wet disc operated by two foot pedals which can be locked together **Steering** hydrostatic **Power take-off** 540 rpm at 1890 engine rpm or 1000 rpm at 2049 engine rpm **Unladen tractor mass** 10505 lb (4765 kg)

**DRAWBAR PERFORMANCE**  
**UNBALLASTED - FRONT DRIVE ENGAGED**  
**MAXIMUM POWER IN SELECTED GEARS**

Power Hp (kW)	Drawbar pull lbs (kN)	Speed mph (km/h)	Crank- shaft speed rpm	Slip %	Fuel Consumption lb/hp.hr (kg/kW.h)	Hp.hr/gal (kW.h/l)	D.E.F Consumption lb/hp.hr (kg/kW.h)	Temp. °F(°C) cool- ing med	Air dry bulb	Barom. inch Hg (kPa)
6th (L3R) Gear										
76.27 (56.87)	8821 (39.24)	3.25 (5.22)	2219	15.0	0.568 (0.346)	12.33 (2.43)	0.045 (0.027)	183 (84)	76 (24)	28.72 (97.26)
7th (L4T) Gear										
83.49 (62.25)	8301 (36.92)	3.77 (6.07)	2200	12.0	0.537 (0.327)	13.04 (2.57)	0.045 (0.027)	184 (84)	72 (22)	28.72 (97.26)
8th (L4R) Gear										
87.99 (65.61)	6814 (30.31)	4.84 (7.79)	2200	7.7	0.510 (0.310)	13.75 (2.71)	0.042 (0.026)	183 (84)	72 (22)	28.72 (97.26)
9th (H1T) Gear										
87.45 (65.21)	6481 (28.83)	5.06 (8.14)	2200	7.1	0.514 (0.313)	13.64 (2.69)	0.041 (0.025)	183 (84)	72 (22)	28.71 (97.22)
10th(H1R) Gear										
90.03 (67.14)	5335 (23.73)	6.33 (10.19)	2200	5.3	0.499 (0.304)	14.04 (2.77)	0.042 (0.026)	183 (84)	72 (22)	28.71 (97.22)
11th (H2T) Gear										
89.22 (66.53)	4151 (18.46)	8.06 (12.97)	2200	3.8	0.500 (0.304)	14.00 (2.76)	0.046 (0.028)	185 (85)	77 (25)	28.71 (97.22)

**UNBALLASTED - FRONT DRIVE ENGAGED-1850 ENGINE RPM**

Power Hp (kW)	Drawbar pull lbs (kN)	Speed mph (km/h)	Crank- shaft speed rpm	Slip %	Fuel Consumption lb/hp.hr (kg/kW.h)	Hp.hr/gal (kW.h/l)	D.E.F Consumption lb/hp.hr (kg/kW.h)	Temp. °F(°C) cool- ing med	Air dry bulb	Barom. inch Hg (kPa)
6th (L3R) Gear										
76.34 (56.92)	8815 (39.21)	3.25 (5.23)	2219	14.9	0.566 (0.344)	12.38 (2.44)	0.045 (0.027)	183 (84)	76 (24)	28.73 (97.29)
7th (L4T) Gear										
83.41 (62.20)	8542 (37.99)	3.67 (5.90)	2164	13.1	0.536 (0.326)	13.07 (2.58)	0.044 (0.027)	185 (85)	72 (22)	28.71 (97.22)
8th (L4R) Gear										
88.41 (65.93)	7477 (33.26)	4.43 (7.13)	2050	9.3	0.491 (0.298)	14.29 (2.81)	0.042 (0.025)	183 (84)	73 (23)	28.72 (97.26)
9th (H1T) Gear										
87.78 (65.46)	7299 (32.47)	4.51 (7.26)	2000	8.8	0.491 (0.298)	14.29 (2.81)	0.041 (0.025)	183 (84)	72 (22)	28.71 (97.22)
10th(H1R) Gear										
91.52 (68.24)	6392 (28.43)	5.37 (8.64)	1900	6.9	0.458 (0.278)	15.31 (3.02)	0.038 (0.023)	183 (84)	71 (22)	28.71 (97.22)
11th (H2T) Gear										
91.10 (67.93)	5107 (22.71)	6.69 (10.77)	1850	5.2	0.452 (0.275)	15.49 (3.05)	0.041 (0.025)	184 (84)	76 (25)	28.70 (97.19)
12th (H2R) Gear										
92.21 (68.76)	4161 (18.51)	8.31 (13.37)	1850	3.8	0.445 (0.271)	15.75 (3.10)	0.042 (0.025)	183 (84)	78 (26)	28.70 (97.19)

TRACTOR SOUND LEVEL WITH CAB	Front Wheel Drive	
	Engaged dB(A)	Disengaged dB(A)
At no load in 8th (4LR) gear	79.8	79.9
Bystander in 16th (4HR) gear		86.2

**TIRES AND WEIGHT**

**Rear Tires** - No., size, ply & psi(kPa)  
**Front Tires** - No., size, ply & psi(kPa)  
**Height of Drawbar**  
**Static Weight with operator** - Rear  
- Front  
- Total

**Tested Without Ballast**

Two 18.4-38;8;16(110)  
Two 14.9-28;6;16(110)  
23.5 in (595 mm)  
6260 lb (2839 kg)  
4420 lb (2005 kg)  
10680 lb (4844 kg)

**REPAIRS AND ADJUSTMENTS:** No repairs or adjustments.

**NOTE:** The performance figures on this report apply to tractors with chassis serial numbers CT00001M and higher.

**REMARKS:** All test results were determined from observed data obtained in accordance with official OECD, SAE and Nebraska test procedures. This tractor did not meet the manufacturer's implement flow claim of 22 GPM (83 l/min) with dual pump system. The manufacturer's 3 point lift claim of 7326 lb (3323 kg) (with 2 external cylinders) was not met when tested by OECD Code 2 standards. The performance figures on this summary were taken from a test conducted under the OECD Code 2 test procedure.

We, the undersigned, certify that this is a true and correct report of official Tractor Test No. **2157**, Nebraska Summary 1038, March 3, 2017.

Roger M. Hoy  
Director

M.F. Kocher  
P.J. Jasa  
J.D. Luck  
Board of Tractor Test Engineers

The 3 point lift performance figures listed below are from tests conducted on the New Holland TS6030 Diesel

### HYDRAULIC PERFORMANCE

CATEGORY: II

Quick Attach: None

OECD Static test

Maximum force exerted through whole range: 6174 lbs (27.46 kN) (2 external lift cylinders)

Two pump system  
two outlet sets combined

i) Sustained pressure of the open relief valve: 2474 psi (171 bar)

ii) Pump delivery rate at minimum pressure and rated engine speed: 18.7 GPM (70.8 l/min)

iii) Pump delivery rate at maximum hydraulic power: 16.2 GPM (61.3 l/min)

Delivery pressure: 2073 psi (143 bar)

Power: 19.6 HP (14.6 kW)

single outlet set

i) Sustained pressure of the open relief valve: 2472 psi (170 bar)

ii) Pump delivery rate at minimum pressure and rated engine speed: 18.3 GPM (69.1 l/min)

iii) Pump delivery rate at maximum hydraulic power: 16.4 GPM (62.1 l/min)

Delivery pressure: 1943 psi (134 bar)

Power: 18.6 HP (13.9 kW)

### THREE POINT HITCH PERFORMANCE (SAE Static test)

Observed maximum pressure psi. (bar) 2480 (171)

Location: lift cylinder

Hydraulic oil temperature: °F (°C) 145 (63)

Location: pump inlet

Category: II

Quick attach: none

#### Two external lift cylinders

System pressure 2210 psi (152 Bar)

Hitch point distance to ground level in. (mm) 8.0 (203) 15.0 (381) 22.0 (559) 29.0 (737) 36.0 (914)

Lift force on frame lb 9270 8622 8199 8361 7326

" " " " " (kN) (41.2) (38.4) (36.5) (37.2) (32.6)

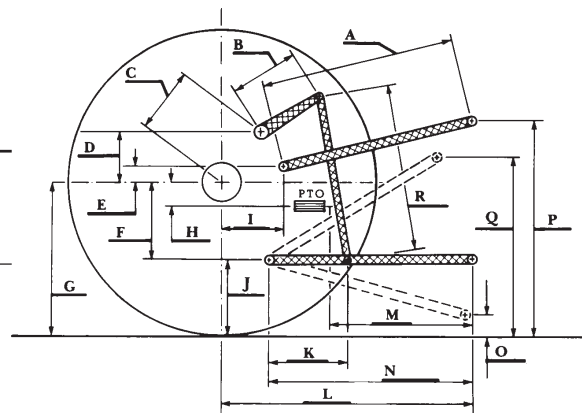

### HITCH DIMENSIONS AS TESTED—NO LOAD

	SAE Test		OECD Test	
	inch	mm	inch	mm
A	27.7	705	28.5	724
B	9.8	250	9.8	250
C	14.1	357	14.1	357
D	13.5	342	13.5	342
E	8.1	205	8.1	205
F	9.0	229	9.0	229
G	30.3	770	30.3	770
H	0.4	10	0.4	10
I	12.7	323	12.7	323
J	21.3	541	21.3	541
K	18.1	460	18.1	460
L	40.8	1037	40.8	1037
M	22.9	581	22.9	581
N	36.6	930	36.6	930
O	8.0	203	8.0	203
P	40.3	1024	45.3	1151
Q	34.0	864	34.0	864
R	32.5	826	32.5	826



CASE IH FARMALL 120A DIESEL

Institute of Agriculture and Natural Resources  
University of Nebraska-Lincoln