

NEBRASKA TRACTOR TEST 1841

AGCO LT90 DIESEL

16 SPEED

POWER TAKE-OFF PERFORMANCE

Power HP (kW)	Crank shaft speed rpm	Gal/hr (l/h)	lb/hp.hr (kg/kW.h)	Hp.hr/gal (kW.h/l)	Mean Atmospheric Conditions
MAXIMUM POWER AND FUEL CONSUMPTION					
Rated Engine Speed—(PTO speed—1101 rpm)					
86.56 (64.55)	2200	6.38 (24.13)	0.516 (0.314)	13.58 (2.67)	
Standard Power Take-off Speed - (1000 rpm)					
87.70 (65.40)	1999	6.05 (22.90)	0.484 (0.294)	14.50 (2.86)	
Maximum Power (2 hours)					
87.70 (65.40)	1999	6.05 (22.90)	0.484 (0.294)	14.50 (2.86)	

VARYING POWER AND FUEL CONSUMPTION

86.56 (64.55)	2200	6.38 (24.13)	0.516 (0.314)	13.58 (2.67)	Air temperature
79.03 (58.94)	2370	6.12 (23.16)	0.543 (0.330)	12.92 (2.54)	75°F (24°C)
58.98 (43.98)	2358	4.92 (18.63)	0.585 (0.356)	11.99 (2.36)	Relative humidity
39.09 (29.15)	2348	3.85 (14.58)	0.691 (0.420)	10.15 (2.00)	44%
20.03 (14.93)	2403	2.91 (11.01)	1.019 (0.620)	6.88 (1.36)	Barometer
1.22 (0.91)	2441	2.01 (7.61)	11.553 (7.027)	0.61 (0.12)	29.03"Hg (98.31 kPa)

Maximum Torque 322 lb.-ft. (436 Nm) at 1251 rpm
 Maximum Torque Rise - 55.3%
 Torque rise at 1798 rpm - 23%

TRACTOR SOUND LEVEL WITH CAB	Front wheel drive	
	Engaged	Disengaged
dB(A)		
At no load in 6th(3LD) gear	77.7	77.7
Bystander	--	--

TIRES AND WEIGHT

Rear Tires—No., size, ply & psi (kPa)
Front Tires—No., size, ply & psi (kPa)
Height of Drawbar
Static Weight with operator—Rear
 — Front
 — Total

Tested Without Ballast

Two 18.4R38; **, 16 (110)
 Two 14.9R28; **, 16 (110)
 19.5 in (495 mm)
 5960 lb (2703 kg)
 4035 lb (1830 kg)
 9995 lb (4533 kg)

Location of Test: Nebraska Tractor Test Laboratory, University of Nebraska, Lincoln Nebraska 68583-0832

Dates of Test: October 13-22, 2004

Manufacturer: AGCO Corporation, Duluth Georgia 30096

FUEL, OIL and TIME: Fuel No. 2 Diesel Specific gravity converted to 60°/60° F (15°/15°C) 0.8420 Fuel weight 7.011 lbs/gal (0.840 kg/l) Oil SAE 15W40 API service classification CE/CF-4 Transmission and hydraulic lubricant AGCO Power Fluid 821 XL fluid Total time engine was operated 9.5 hours

ENGINE: Make Cummins Diesel **Type** four cylinder vertical with turbocharger **Serial No.** 21602955 **Crankshaft** lengthwise **Rated engine speed** 2200 **Bore and stroke** 4.094" x 5.197" (104.0 mm x 132.0 mm) **Compression ratio** 17.5 to 1 **Displacement** 274 cu in (4485 ml) **Starting system** 12 volt **Lubrication** pressure **Air cleaner** one paper element and one polyester felt element **Oil filter** one full flow cartridge **Oil cooler** engine coolant heat exchanger for crankcase oil **Fuel filter** one paper element and water separator **Muffler** underhood **Exhaust** vertical **Cooling medium temperature control** thermostat and variable speed fan

ENGINE OPERATING PARAMETERS: Fuel rate: 42.4 - 46.7 lb/h (19.2 - 21.2 kg/h) **High idle:** 2350 - 2450 rpm **Turbo boost:** nominal 12.7 - 15.4 psi (87- 106 kPa) as measured 14.0 psi (97 kPa)

CHASSIS: Type front wheel assist **Serial No.** N147018 **Tread width** rear 56.1" (1530 mm) to 83.9" (2144 mm) front 54.0" (1568 mm) to 78.0" (2051 mm) **Wheelbase** 100.5" (2553 mm) **Hydraulic control system** direct engine drive **Transmission** selective gear fixed ratio with partial (2) range operator controlled powershift **Nominal travel speeds mph (km/h)** first 1.67 (2.68) second 2.10 (3.38) third 2.51 (4.04) fourth 3.18 (5.11) fifth 3.72 (5.98) sixth 4.70 (7.56) seventh 5.03 (8.10) eighth 6.23 (10.03) ninth 6.36 (10.24) tenth 7.88 (12.68) eleventh 9.43 (15.17) twelfth 11.90 (19.15), thirteenth 13.94 (22.43) fourteenth 17.62 (28.35) fifteenth 18.86 (30.35) sixteenth 23.84 (38.36) reverse 1.67 (2.68), 2.10 (3.38), 2.51 (4.04), 3.18, (5.11), 3.72 (5.98), 4.70 (7.56), 5.03 (8.10), 6.23 (10.03), 6.36 (10.24), 7.88 (12.68), 9.43 (15.17), 11.90 (19.15), 13.94 (22.43), 17.62 (28.35), 18.86 (30.35), 23.84 (38.36) **Clutch** multiple wet disc electro-hydraulically operated by foot pedal **Brakes** single wet disc hydraulically operated by two foot pedals which can be locked together **Steering** hydrostatic **Power take-off** 540 rpm at 1902 engine rpm or 1000 rpm at 2000 engine rpm **Unladen tractor mass** 9820 lb (4454 kg)

THREE POINT HITCH PERFORMANCE (OECD Static Test)

CATEGORY: II			
Quick Attach: None			
Maximum Force Exerted Through Whole Range:	7817 lbs	(34.8 kN)	High lift option 9189 lbs (40.9 kN)
i) Opening pressure of relief valve:	NA		Combined flow with both pumps 3079 psi (212 bar)
Sustained pressure of the open relief valve:	2753 psi	(190 bar)	
ii) Pump delivery rate at minimum pressure and rated engine speed:	15.2 GPM	(57.5 l/min)	24.9 GPM (94.3 l/min)
iii) Pump delivery rate at maximum hydraulic power:	15.2 GPM	(57.5 l/min)	25.6 GPM (96.9 l/min)
Delivery pressure:	2498 psi	(172 bar)	2208 psi (152 bar)
Power:	22.2 HP	(16.5 kW)	33.0 Hp (24.6 kW)

REPAIRS AND ADJUSTMENTS: No repairs or adjustments

REMARKS: All test results were determined from observed data obtained in accordance with official OECD, SAE and Nebraska test procedures. This tractor did not meet the manufacturer's claim of 26.4 GPM (100 lpm) combined hydraulic flow at remote outlets. For the maximum power tests, the fuel temperature at the injection pump was maintained at 168°F (76°C).

THREE POINT HITCH PERFORMANCE

Observed Maximum Pressure psi.(bar)	2770(191)
Location:	lift cylinder
Hydraulic oil temperature: °F(°C)	152(67)
Location:	hydraulic valve
Category:	II
Quick attach:	none

We, the undersigned, certify that this is a true and correct report of official Tractor Test No. **1841**, February 4, 2005.

Leonard L. Bashford
Director

SAE Static Test—System pressure 2490 psi (172 Bar)

Hitch point distance to ground level in. (mm)	9.9(251)	15.0(381)	22.0(559)	29.0(737)	36.0(914)
Lift force on frame lb	15561	12897	11745	10314	9126
" " " " " (kN)	(69.2)	(57.4)	(51.0)	(45.9)	(40.6)

M.F. Kocher
V.I. Adamchuk
W.P. Campbell
Board of Tractor Test Engineers

High lift Option

SAE Static Test—System pressure 2490 psi (172 Bar)

Hitch point distance to ground level in. (mm)	10.2(259)	15.0(381)	22.0(559)	29.0(737)	36.0(914)
Lift force on frame lb	18747	15849	14310	12789	11421
" " " " " (kN)	(83.4)	(70.5)	(63.7)	(56.9)	(50.8)

	SAE test		OECD test	
	inch	mm	inch	mm
A	24.8	629	24.8	629
B	11.6	295	11.6	295
C	13.9	353	13.9	353
D	13.0	330	13.0	330
E	7.9	200	7.9	200
F	10.2	260	10.2	260
G	30.3	770	30.3	770
H	1.4	35	1.4	35
I	16.2	413	16.2	413
J	20.1	510	20.1	510
K	24.2	615	24.2	615
L	41.2	1046	41.2	1046
M	23.5	596	23.5	596
N	37.2	946	37.2	946
O	8.0	203	8.0	203
P	40.2	1020	44.1	1120
Q	33.5	850	33.5	850
R	29.0	737	29.0	737

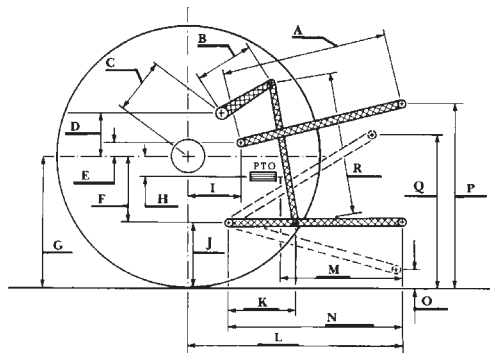

HITCH DIMENSIONS AS TESTED - NO LOAD



AGCO LT 90 Diesel